



# END-OF-ARM-TOOLING

Product catalog



## WE CAN MOVE EVERYTHING.

With know-how, expertise, flexibility and professional project management, we enable you to the best solution for your handling task, in the vacuum, gripping and lifting technology.



### Box

Efficient handling and transportation of cardboard packaging in storage and shipping areas.



### Injection molded parts

Low-impact removal of hot plastic parts, cutting of sprues.



### Sacks

Ergonomic, safe handling and picking of sacks.



### Bags/Pouches

Handling of unstable flowpacks and bags with different textures.



### Sheet metal

Fast cycling times and high process reliability for sheet metal transfer, body car handling and machine loading.



### Wood

Handling of wooden elements with different surfaces, machine loading.



### Glass/bottles

Impression-free, safe handling and assembly of panes, glass and window elements.



### Paper/foils

Precise and reliable handling without soaking in the product.



### Drums

Safe handling of heavy drums, buckets and canisters.



### Food

Flexible and FDA-compliant handling for direct contact with food.



### Pallets

Easy and safe handling of pallets for a smooth material flow.



### Electronic parts

Clean and flexible handling of very small components with maximum precision.



# AUTOMATION SOLUTIONS ACCORDING TO YOUR NEEDS

We are your global partner for all requirements in the industrial automation industry. Thanks to our many years of experience, reliability and flexibility, we always find the right solution to maximize your process reliability.

Production and logistics mean movement. In most industries, products are picked up, held, deposited, turned, turned over, positioned and lifted.

Vacuum technology can be used to move workpieces safely and quickly, but above all to handle them gently and without causing damage. We have a comprehensive range of innovative and high-quality products for all these applications. With our customer-specific solutions, you can optimize your production processes while supporting your employees in their daily work.

## **Are you looking for an automation approach and want to improve your processes?**

We are more than just a supplier of components. With our expertise, application know-how and professional project management, we provide the optimum solution for your handling task in vacuum, gripping and lifting technology.

## **Do you want to increase efficiency and productivity at the same time as working ergonomically?**

We work closely with our customers and therefore always find an answer- from standard solutions to customized designs the gripper construction.

Our goal: to optimize processes in production and logistics with individual components and customized solutions.

Personal contact, fast response times and expertise are our path to successful projects. We are active for you worldwide through our large partner network.

We keep moving for **you** so that production and logistics run reliably and smoothly.

# THE EXTENSIVE FIPA RANGE

When it comes to the reliable handling of workpieces using vacuum technology or pneumatics we are at your disposal as a competent partner. Whether you need gripper components such as **sprue grippers, gripper fingers, quick-change systems, air nippers or complete gripping systems** you need: FIPA's portfolio has it all. We carry all products relating to gripper technology in this catalog.



## Are you looking for the right vacuum cups?

In the pick and place field, all vacuum cups have the same task: lifting parts and moving them without causing damage. Different suction cups are used depending on the shape, size and material of the goods to be handled. We have an extensive range of flat, bellows and oval suction cups, as well as matching holders and spring levelers, which we present in our vacuum cups catalog.



## Are you looking for the right vacuum component?

The highest level of professionalism in generating, regulating, controlling and vacuum – this is guaranteed by the various vacuum components from FIPA. In the catalog for vacuum components you will find everything from suitable vacuum generation, vacuum filters, hoses and connecting elements.



## Do you want to make lifting heavy loads easier?

Take the strain from your employees with the ideal tube lifter for your application. Our goal is to make your material flow as efficient and ergonomic as possible.

Quick-change systems	7
<hr/>	
Extrusion systems	45
<hr/>	
Gripper arms	113
<hr/>	
Grippers	133
<hr/>	
Nipper technology	271
<hr/>	
Linear technology	309
<hr/>	
Vacuum gripping systems	341
<hr/>	
Electronics and sensors	371



S Series – square .....	8
SR Series – round .....	19
MPS Series – automatic .....	36



# Quick-change systems | S Series

Quick-change systems – square, robot side, without fittings

## Quick-change systems – square, robot side, without fittings

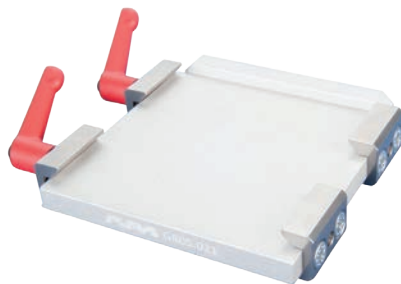

GR05.041

### Product notes

- > Manual interface between robot and gripper system
- > Minimized down time due to fast gripper change
- > Available in four sizes
- > Clamping levers included in scope of delivery
- > Base plates and pneumatic connections not included in scope of delivery

### Technical data

Item no.	Industry standard code	Lifting force [N]	Length [mm]	Weight [g]	Accessories
<b>GR05.041</b>	GR-0	50	60	315	Gripper mounting plate: GR05.042 Quick-connection coupler: KIT1-GR05.041
<b>GR05.021</b>	GR-1	100	100	570	Gripper mounting plate: GR05.022 Quick-connection coupler: KIT1-GR05.021
<b>GR05.031</b>	GR-2	200	160	1,970	Gripper mounting plate: GR05.032 Gripper mounting plate: GR05.063 Gripper mounting plate: GR-XL05.032 Quick-connection coupler: KIT1-GR05.031
<b>GR05.051</b>	GR-3	400	250	4,520	Gripper mounting plate: GR05.052 Gripper mounting plate: GR05.070 Gripper mounting plate: GR-XL05.052 Quick-connection coupler: KIT1-GR05.031

### Dimensions

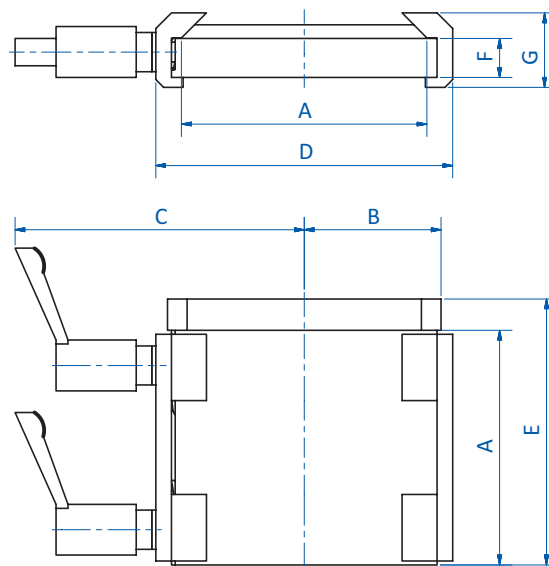

GR05.041 | GR05.021



## Dimensions

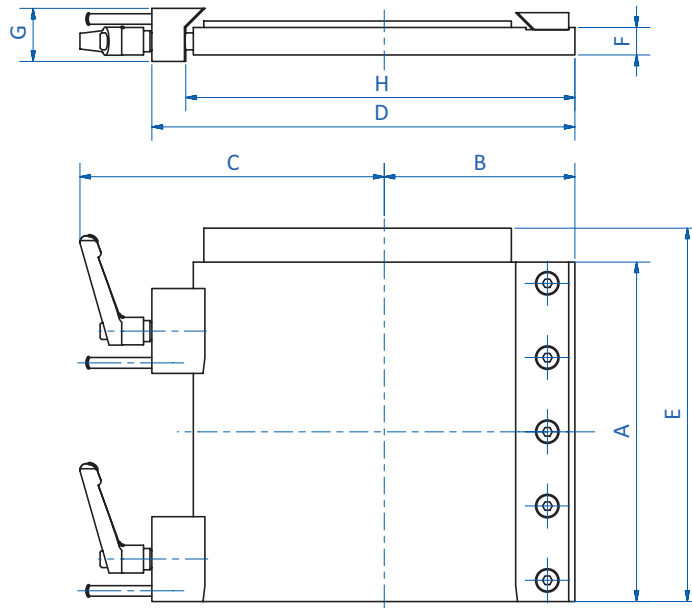

GR05.031

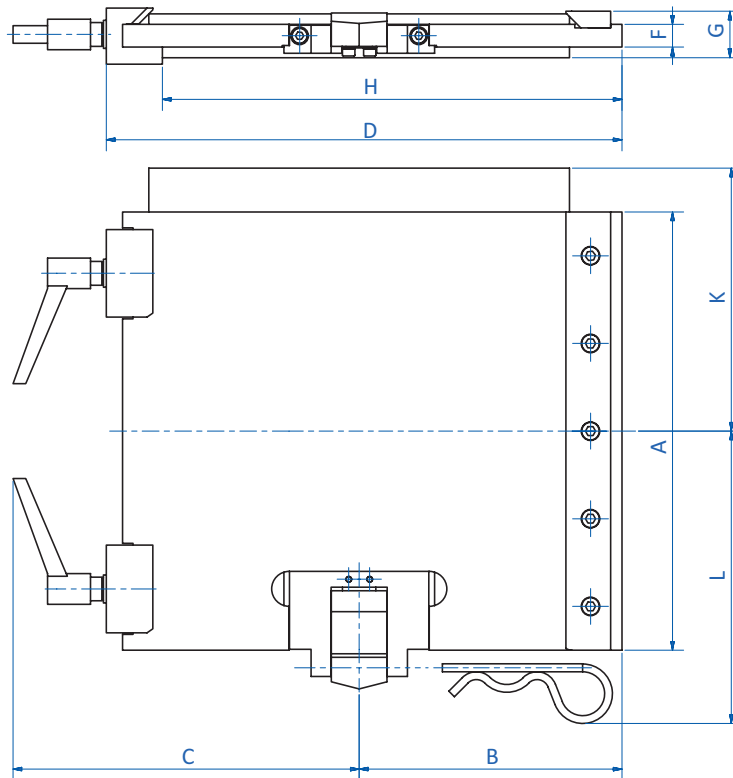

GR05.051

Item no.	A [mm]	B [mm]	C [mm]	D [mm]	E [mm]	F [mm]	G [mm]	H [mm]	K [mm]	L [mm]
GR05.041	60	38	74	76	68	10	19	62	--	--
GR05.021	100	57.5	91.5	115	110	10	20	101	--	--
GR05.031	160	90	143.5	198	176	13	25	183	--	--
GR05.051	250	150	197.5	290	--	13	32	259	150	167





### Gripper mounting plates

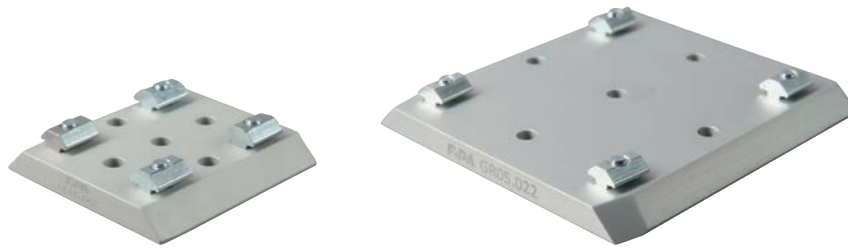

#### Product notes

- > Mounting plate for profile based grippers
- > Includes screws and slot nuts

#### Technical data

Item no.	Industry standard code	Suitable for extrusion system	Length [mm]	Weight [g]	Suitable robot adapter plates
<b>GR05.042</b>	GR-0	SLine / MLine / JLine (Universal)	60	84	GR05.041
<b>GR05.022</b>	GR-1	SLine / MLine / JLine (Universal)	100	230	GR05.021
<b>GR05.032</b>	GR-2	SLine	160	635	GR05.031
<b>GR05.052</b>	GR-3	SLine	250	1,650	GR05.051
<b>GR05.063</b>	GR-2	MLine / JLine	160	690	GR05.031
<b>GR05.070</b>	GR-3	MLine / JLine	250	1,670	GR05.051
<b>GR-XL05.032</b>	GR-2	XLine	160	752	GR05.031
<b>GR-XL05.052</b>	GR-3	XLine	250	1,784	GR05.051

#### Dimensions

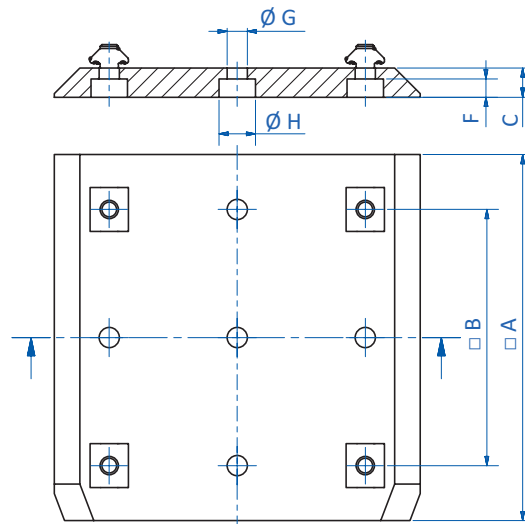



Item no.	□ A [mm]	□ B [mm]	C [mm]	F [mm]	∅ G [mm]	∅ H [mm]
GR05.042	60	35	8	5	5.5	10
GR05.022	100	70	8	5	5.5	10
GR05.032	160	120	10	4.5	5.5	10
GR05.052	250	200	10	7	5.5	10
GR05.063	160	120	10	4.9	6.4	11
GR05.070	250	200	10	4.9	6.4	11
GR-XL05.032	160	120	10	6.5	8.5	14
GR-XL05.052	250	200	10	6.5	8.5	14



### Gripper mounting plates for customisation

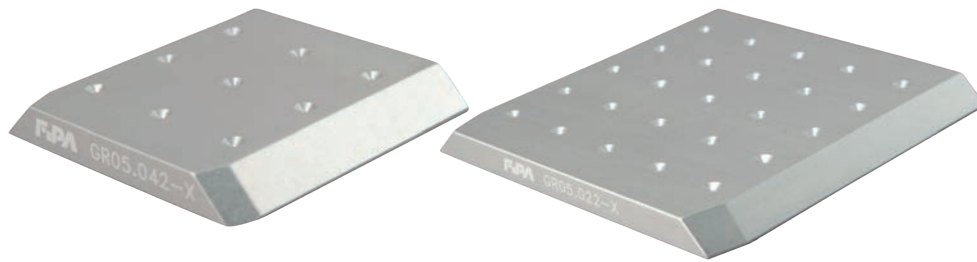

#### Product notes

- > Punch-marked for easy drilling

#### Technical data

Item no.	Industry standard code	Length [mm]	Weight [g]	Suitable robot adapter plates
GR05.042-X	GR-0	60	84	GR05.041
GR05.022-X	GR-1	100	208	GR05.021
GR05.032-X	GR-2	160	635	GR05.031
GR05.052-X	GR-3	250	1,650	GR05.051

#### Dimensions

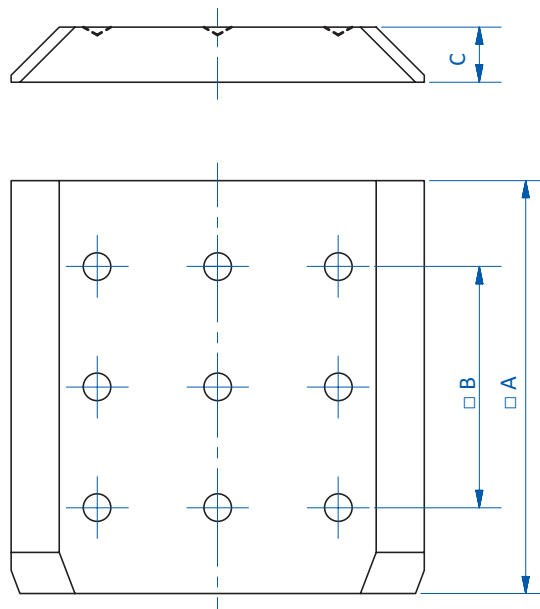

GR05.042-X



Dimensions

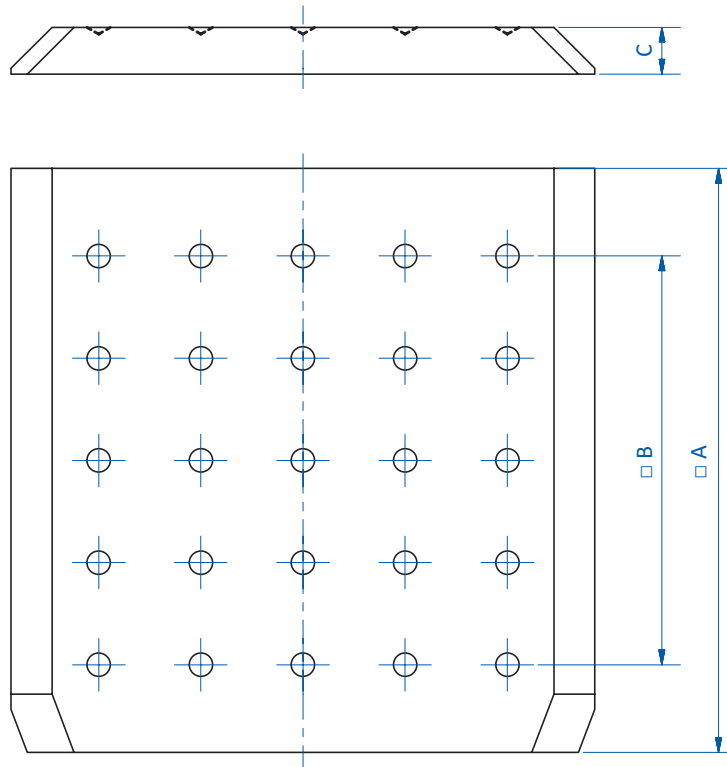

GR05.022-X | GR05.032-X

Continued on the next page



# Quick-change systems | S Series

Gripper mounting plates for customisation

## Dimensions

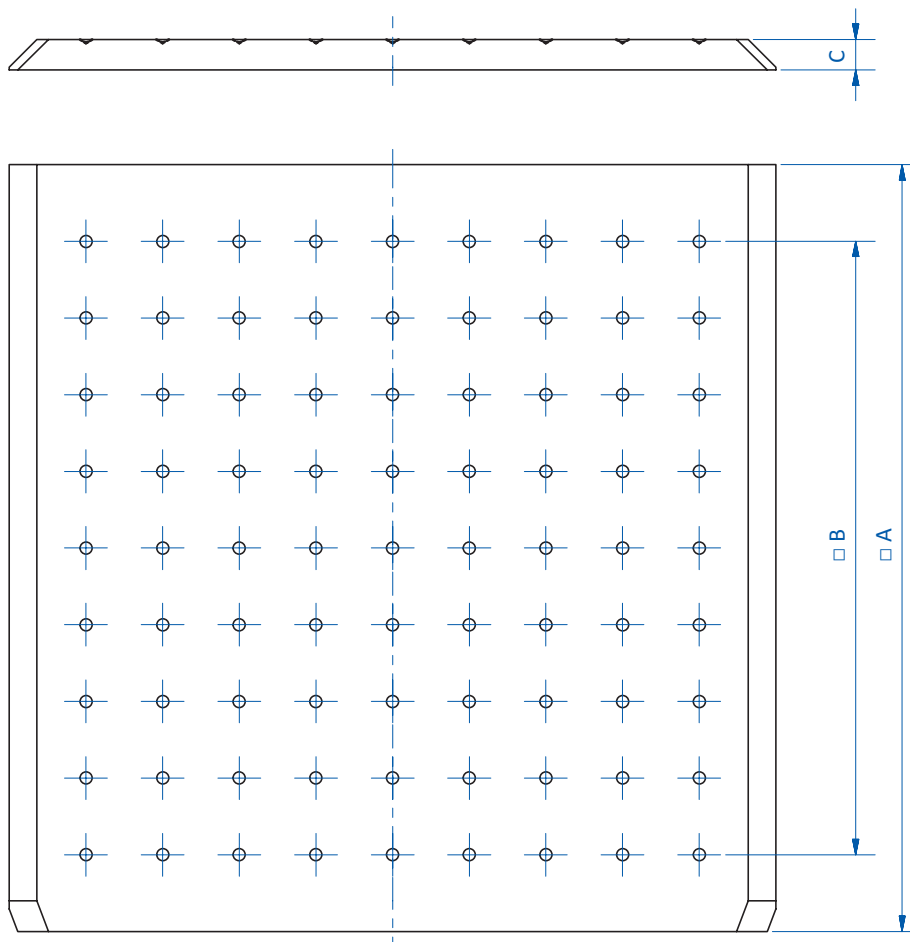

GR05.052-X

Item no.	□ A [mm]	□ B [mm]	C [mm]
GR05.042-X	60	35	8
GR05.022-X	100	70	8
GR05.032-X	160	120	10
GR05.052-X	250	200	10



### Gripper mounting plates – spring loaded

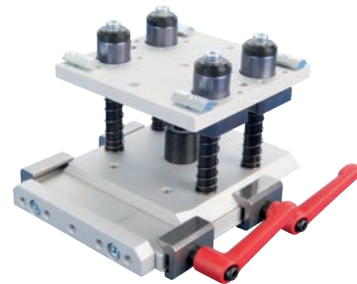

Gripper mounting plate with quick-change system GR05.021

#### Product notes

- > Base plate for compensating ejection stroke of molding machine
- > High-quality slide bearings ensure accurate guidance
- > A second set of springs with higher spring rate included in scope of delivery
- > Slot nuts and mounting screws included in scope of delivery

#### Technical data

Item no.	Industry standard code	Suitable for extrusion system	Stroke [mm]	Spring stiffness (already built in) [N/mm]	Spring stiffness (alternatively) [N/mm]	Weight [g]	Suitable robot adapter plates
GR05.023	GR-1	SLine	30	0.143	0.349	690	GR05.021
GR05.024	GR-1	SLine / MLine	30	0.143	0.349	690	GR05.021

#### Dimensions

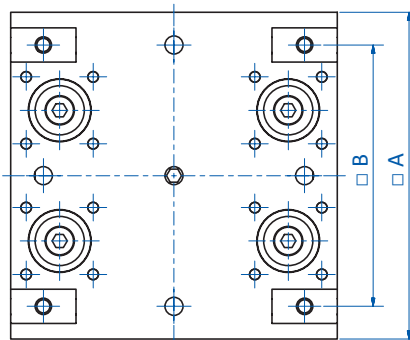
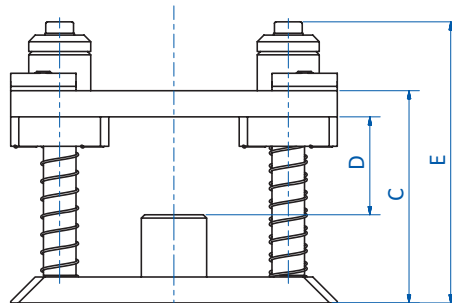

Item no.	A [mm]	B [mm]	C [mm]	D [mm]	E [mm]
GR05.023	100	80	65	30	86
GR05.024	110	85	65	30	86



### Adapter for S Series quick change systems



#### Product notes

- > Mount grippers with smaller dovetail plate to a larger robot side
- > No tools required

#### Technical data

Item no.	Industry standard code	Weight [g.]	Accessories
<b>GR05.206</b>	GR-1 => GR-0	256	Gripper mounting plate: GR05.042 Robot adapter plate: GR05.021
<b>GR05.207</b>	GR-2 => GR-1	715	Gripper mounting plate: GR05.022 Robot adapter plate: GR05.031
<b>GR05.209</b>	GR-3 => GR-2	2,465	Gripper mounting plate: GR05.032 Gripper mounting plate: GR05.063 Robot adapter plate: GR05.051

#### Dimensions

A [mm]	B [mm]	C [mm]
100	60	10
160	100	9
250	160	13

#### Dimensions

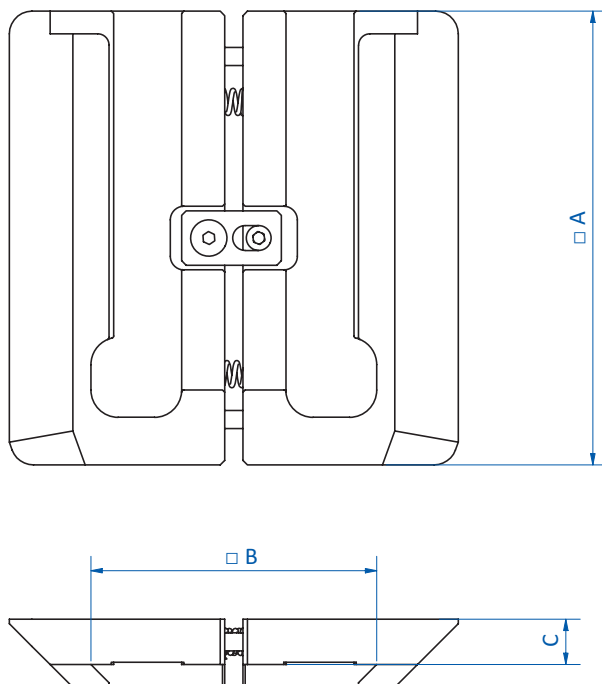

#### Application example

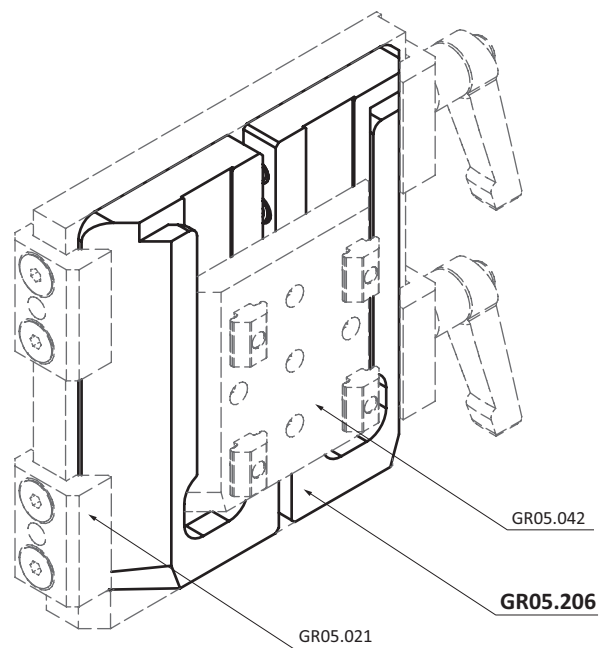





### Wall brackets for square quick-change plates



Wall bracket with quick-change plate

#### Product notes

- > Efficient storage of gripping systems
- > Fixing kit included in delivery

#### Technical data

Item no.	Weight [g]	Compatible gripper mounting plate
GR05.042-W	145	GR05.042
GR05.022-W	212	GR05.022
GR05.032-W	385	GR05.032
GR05.052-W	1,218	GR05.052

#### Application example

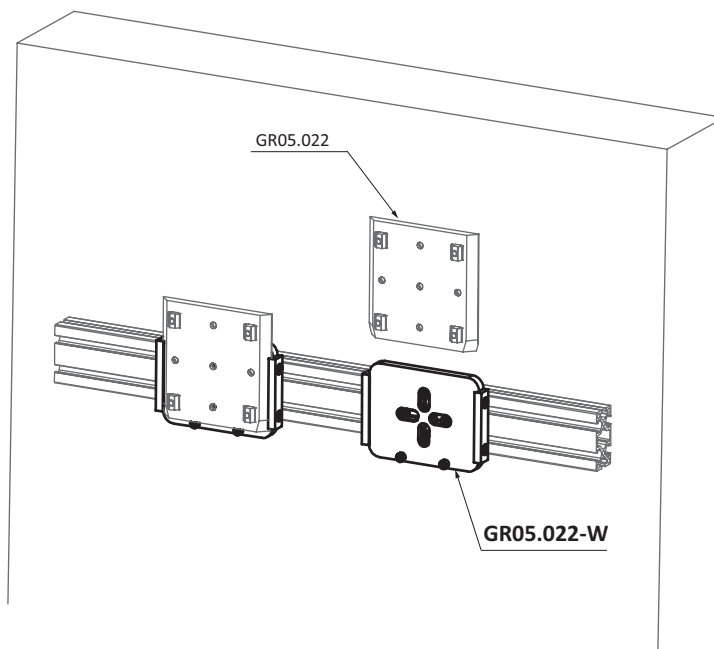

Continued on the next page →



### Dimensions

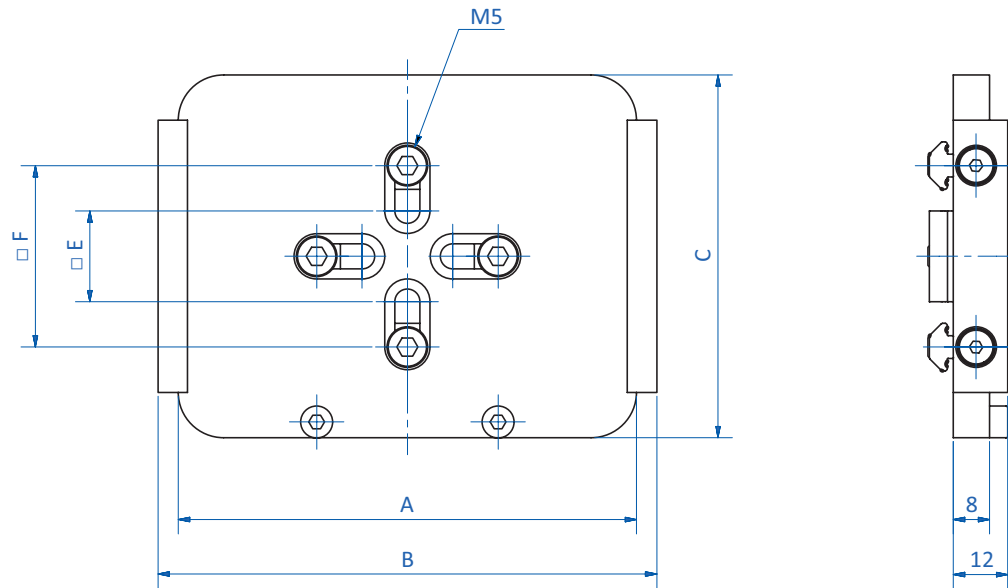

Item no.	A [mm]	B [mm]	C [mm]	□ E [mm]	□ F [mm]
<b>GR05.042-W</b>	60	70	80	20	40
<b>GR05.022-W</b>	101	110	80	20	40
<b>GR05.032-W</b>	161	170	100	20	40
<b>GR05.052-W</b>	251	260	200	60	120



## Round quick-changers Ø 50 mm, 6 air inlets – robot side



SR50-A-SL-MV with locking indication SAFE-LOCK

### Product notes

- > Manual interface between robot and gripper system
- > Air connections always correctly aligned
- > Body made of anodized aluminum alloy
- > Model MV comes with micro valves for automatic air or vacuum lock off during decoupling
- > Model SL with secure SAFE-LOCK ensures maximum functional reliability and optical locking indication (red/green)

### Technical data

Item no.	SR50-A	SR50-A-MV	SR50-A-SL	SR50-A-SL-MV
Lifting force [N]	200	200	200	200
Number of pneumatic connections	6xM5	6xM5	6xM5	6xM5
Working pressure [bar (psi)]	0 - 6 (0 - 87)	0 - 6 (0 - 87)	0 - 6 (0 - 87)	0 - 6 (0 - 87)
Max. torque [Nm]	50	50	50	50
Max. bending moment [Nm]	30	30	30	30
Repeat accuracy [mm]	+/- 0.025	+/- 0.025	+/- 0.025	+/- 0.025
Micro valves	without	integrated	without	integrated
Snap-on	without	without	SAFE-LOCK for secure locking	SAFE-LOCK for secure locking
Weight [g]	68	72	70	74
Suitable electrical connectors	20.537	20.537	20.537	20.537

### Display of optical locking indication SAFE-LOCK

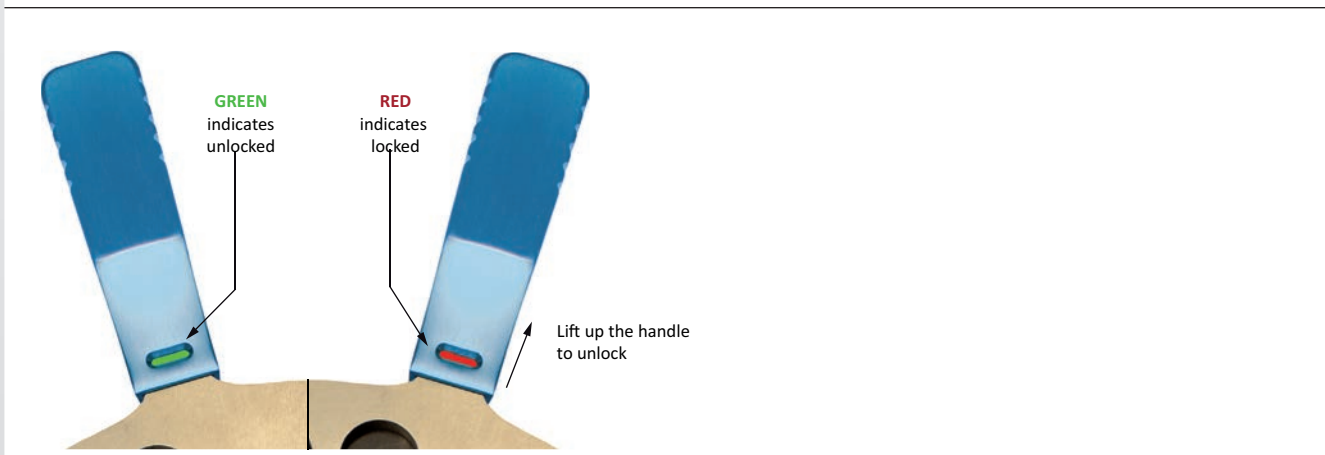

Continued on the next page →



# Quick-change systems | SR Series

Round quick-changers  $\varnothing$  50 mm, 6 air inlets – robot side

## Dimensions

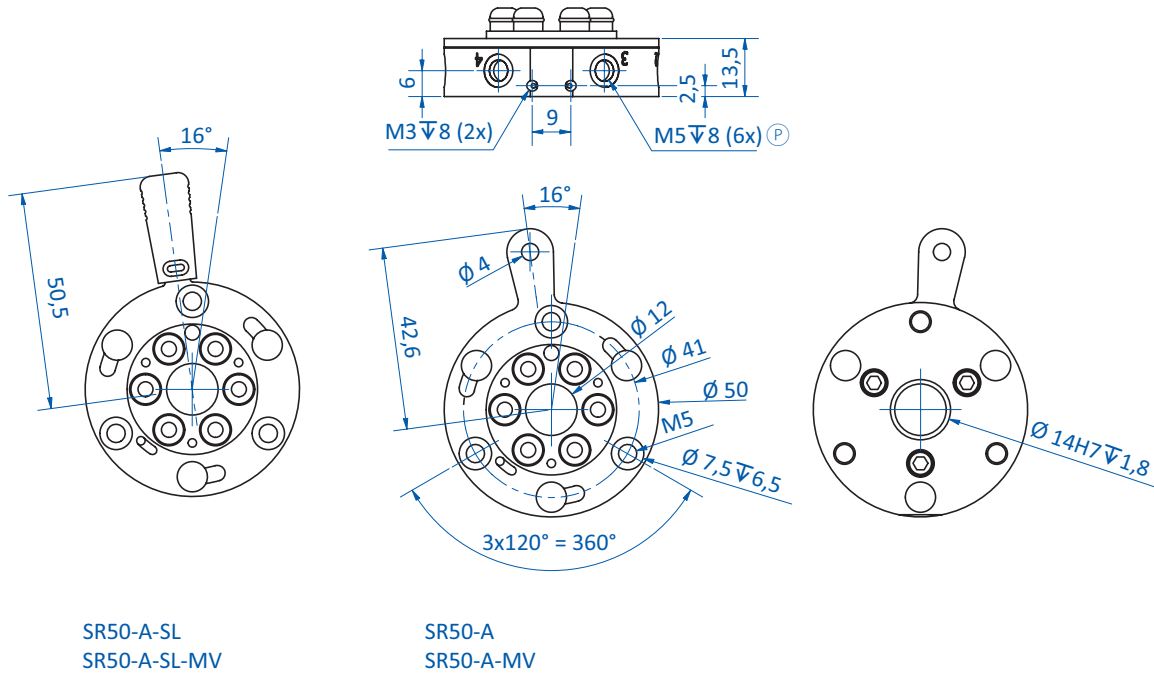

Ⓟ = Pneumatic connection



## Round quick-changers $\varnothing$ 50 mm, 6 air inlets – gripper side

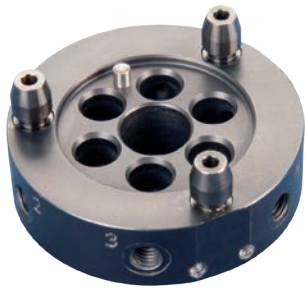

### Product notes

- > Manual interface between robot and gripper system
- > Air connections always correctly aligned
- > Body made of anodized aluminum alloy

### Technical data

Item no.	SR50-B
Lifting force [N]	200
Number of pneumatic connections	6xM5
Working pressure [bar (psi)]	0 - 6 (0 - 87)
Max. torque [Nm]	50
Max. bending moment [Nm]	30
Repeat accuracy [mm]	+/- 0.025
Weight [g]	69
Suitable electrical connectors	20.538

### Dimensions

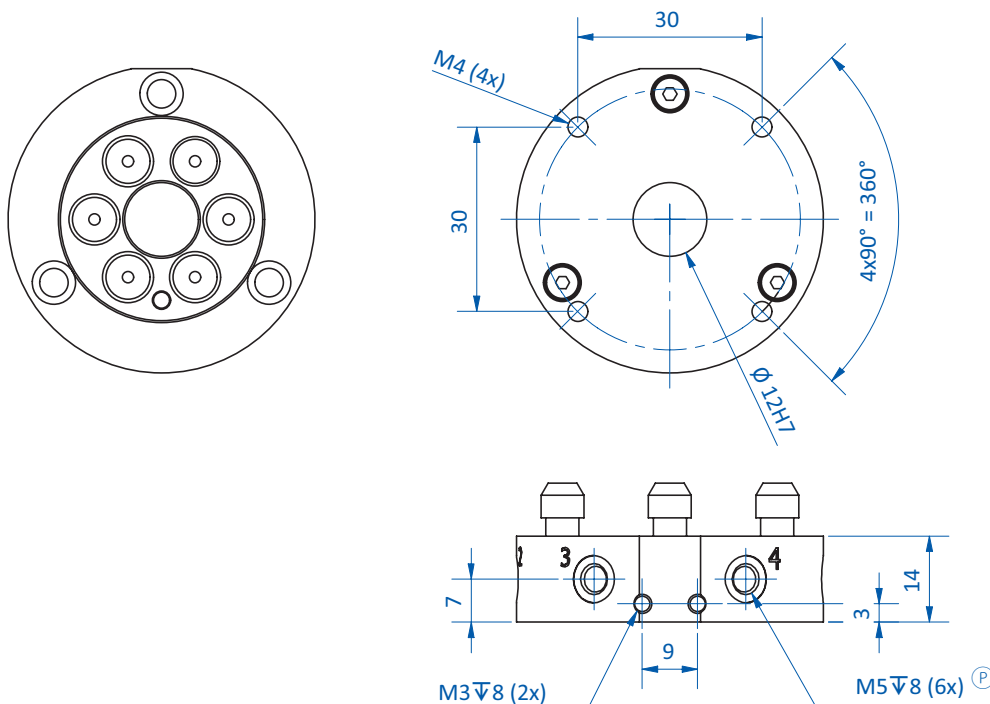

Ⓟ = Pneumatic connection



# Quick-change systems | SR Series

Round quick-changers Ø 90 mm, 8 air inlets – robot side

## Round quick-changers Ø 90 mm, 8 air inlets – robot side



SR90-A-SL-2 with locking indication SAFE-LOCK

### Product notes

- > Manual interface between robot and gripper system
- > Air connections always correctly aligned
- > Body made of anodized aluminum alloy
- > Model MV comes with micro valves for automatic air or vacuum lock off during decoupling
- > Model SL with secure SAFE-LOCK ensures maximum functional reliability and optical locking indication (red/green)

### Technical data

Item no.	SR90-A-2	SR90-A-MV-2	SR90-A-SL-2	SR90-A-SL-MV-2
Lifting force [N]	400	400	400	400
Number of pneumatic connections	8xG1/8	8xG1/8	8xG1/8	8xG1/8
Working pressure [bar (psi)]	0 - 6 (0 - 87)	0 - 6 (0 - 87)	0 - 6 (0 - 87)	0 - 6 (0 - 87)
Max. torque [Nm]	100	100	100	100
Max. bending moment [Nm]	60	60	60	60
Repeat accuracy [mm]	+/- 0.025	+/- 0.025	+/- 0.025	+/- 0.025
Micro valves	without	integrated	without	integrated
Snap-on	without	without	SAFE-LOCK for secure locking	SAFE-LOCK for secure locking
Weight [g]	313	329	331	343
Suitable electrical connectors	20.535	20.535	20.535	20.535

### Display of optical locking indication SAFE-LOCK

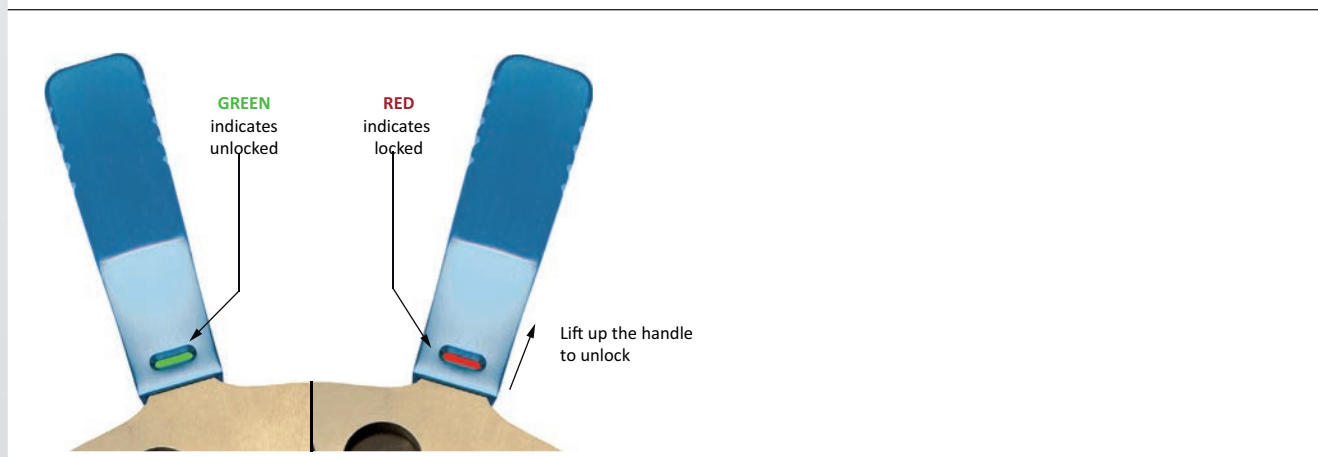



Dimensions

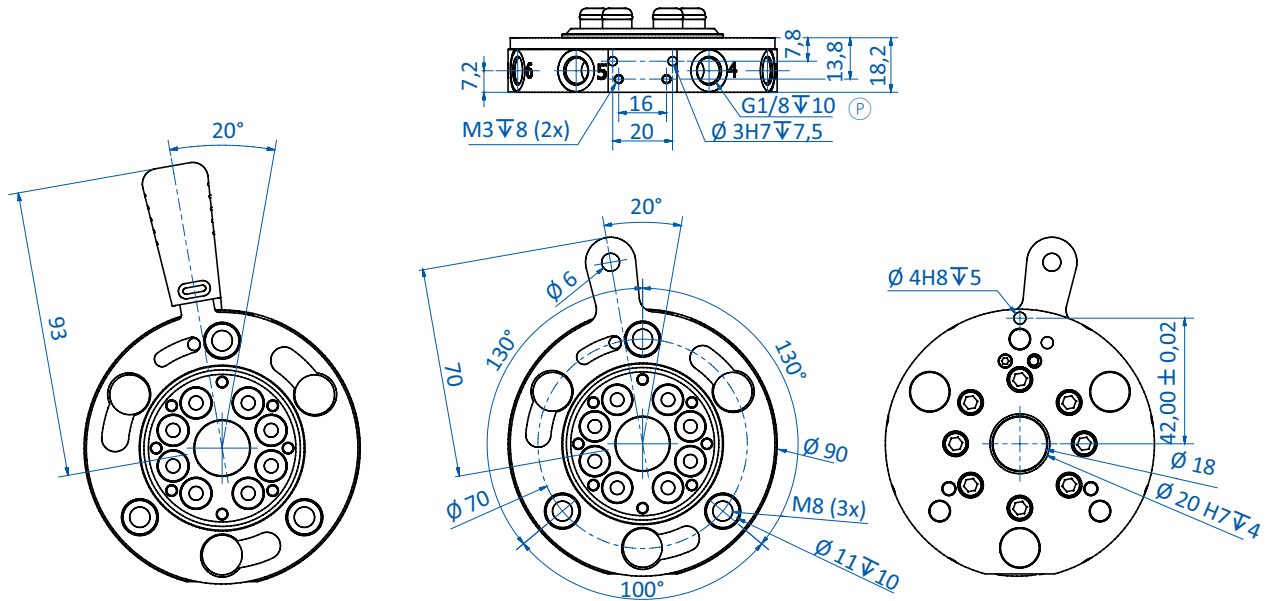

SR90-A-SL-2  
SR90-A-SL-MV-2

SR90-A-2  
SR90-A-MV-2

(P) = Pneumatic connection





# Quick-change systems | SR Series

Round quick-changers  $\varnothing$  90 mm, 8 air inlets – gripper side

## Round quick-changers $\varnothing$ 90 mm, 8 air inlets – gripper side



### Product notes

- > Manual interface between robot and gripper system
- > Air connections always correctly aligned
- > Body made of anodized aluminum alloy

### Technical data

Item no.	SR90-B-2
Lifting force [N]	400
Number of pneumatic connections	8xG1/8
Working pressure [bar (psi)]	0 - 6 (0 - 87)
Max. torque [Nm]	100
Max. bending moment [Nm]	60
Repeat accuracy [mm]	+/- 0.025
Weight [g]	220
Suitable electrical connectors	20.536

### Dimensions

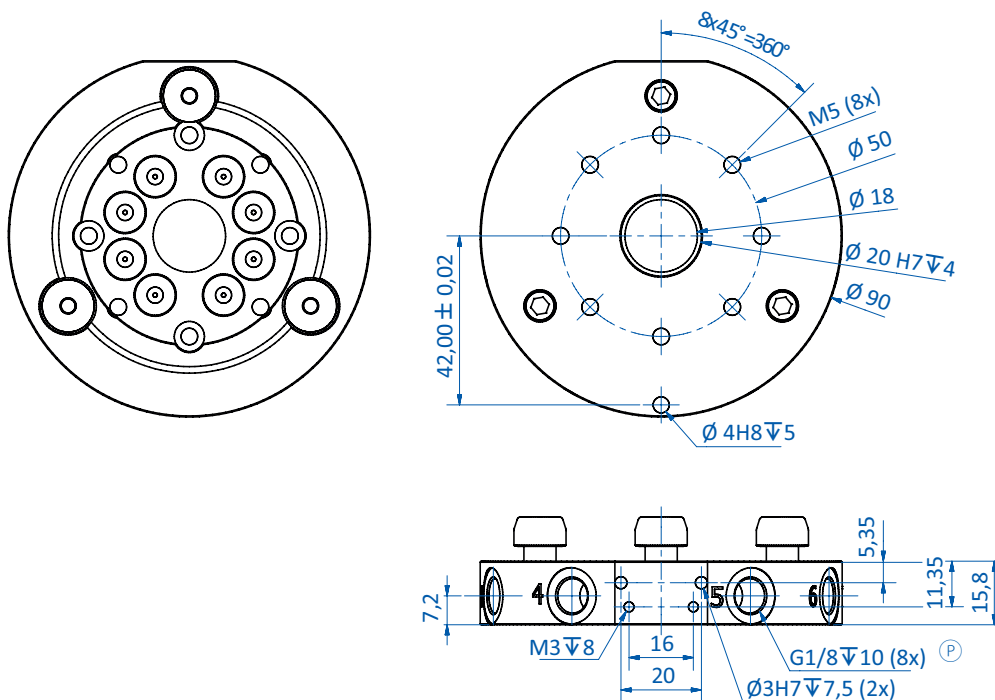

Ⓟ = Pneumatic connection



## Round quick-changers Ø 150 mm, 10 air inlets – robot side



SR150-A-2

### Product notes

- > Manual interface between robot and gripper system
- > Air connections always correctly aligned
- > Body made of anodized aluminum alloy
- > Model SL with secure SAFE-LOCK ensures maximum functional reliability and optical locking indication (red/green)

### Technical data

Item no.	SR150-A-2	SR150-A-SL-2
Lifting force [N]	1,000	1,000
Number of pneumatic connections	10xG1/4	10xG1/4
Working pressure [bar (psi)]	0 - 6 (0 - 87)	0 - 6 (0 - 87)
Max. torque [Nm]	250	250
Max. bending moment [Nm]	100	100
Repeat accuracy [mm]	+/- 0.025	+/- 0.025
Micro valves	without	without
Snap-on	without	SAFE-LOCK for secure locking
Weight [g]	1,192	1,206
Suitable electrical connectors	20.535	20.535

### Display of optical locking indication SAFE-LOCK

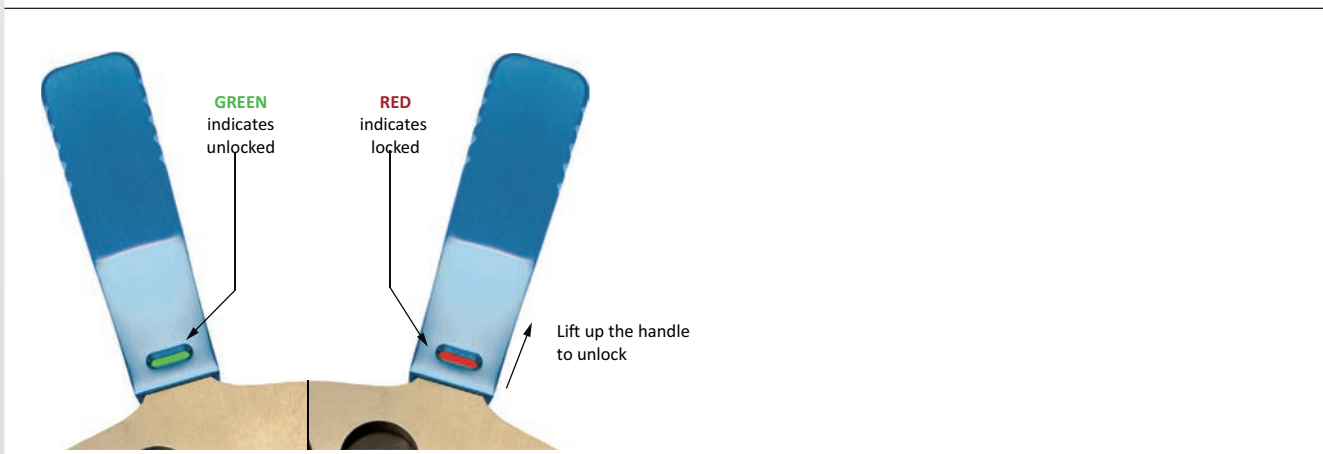

Continued on the next page →



# Quick-change systems | SR Series

Round quick-changers  $\varnothing 150$  mm, 10 air inlets – robot side

## Dimensions

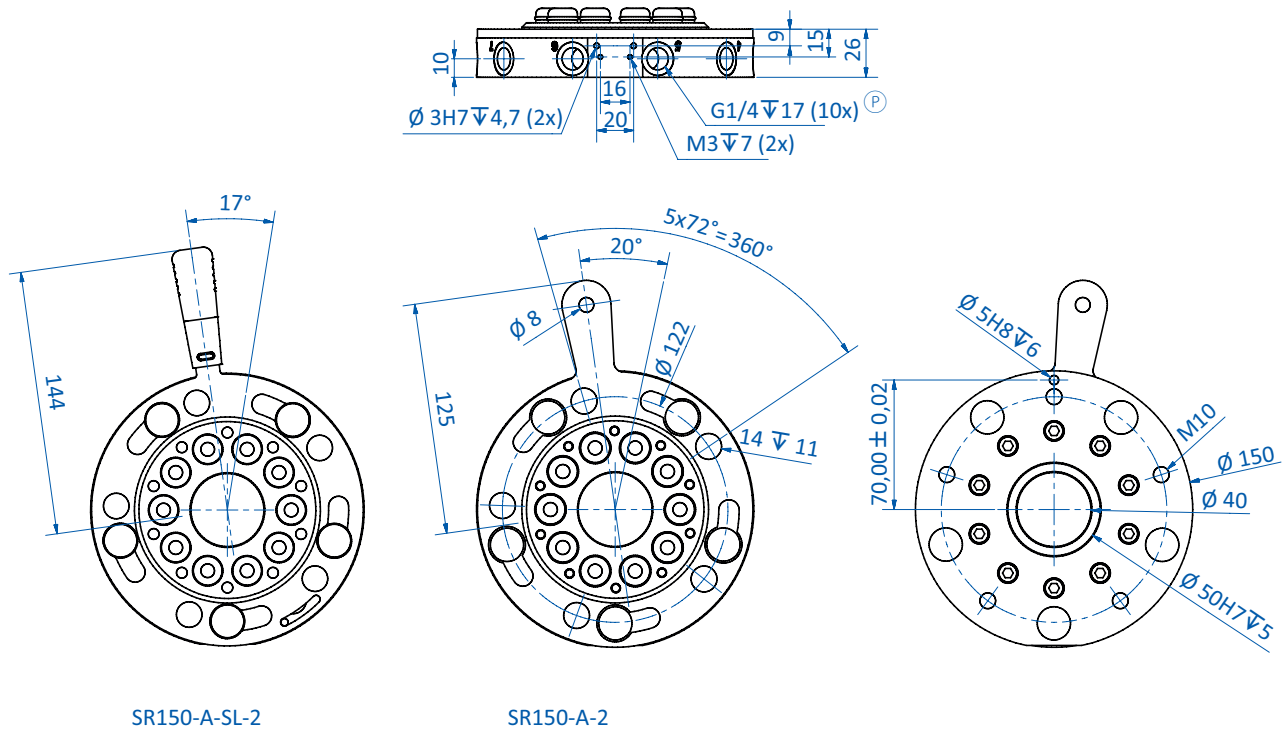

Ⓟ = Pneumatic connection



## Round quick-changers $\varnothing$ 150 mm, 10 air inlets – gripper side



### Product notes

- > Manual interface between robot and gripper system
- > Air connections always correctly aligned
- > Body made of anodized aluminum alloy

### Technical data

Item no.	SR150-B-2
Lifting force [N]	1,000
Number of pneumatic connections	10xG1/8
Working pressure [bar (psi)]	0 - 6 (0 - 87)
Max. torque [Nm]	250
Max. bending moment [Nm]	100
Repeat accuracy [mm]	+/- 0.025
Weight [g]	850
Suitable electrical connectors	20.536

### Dimensions

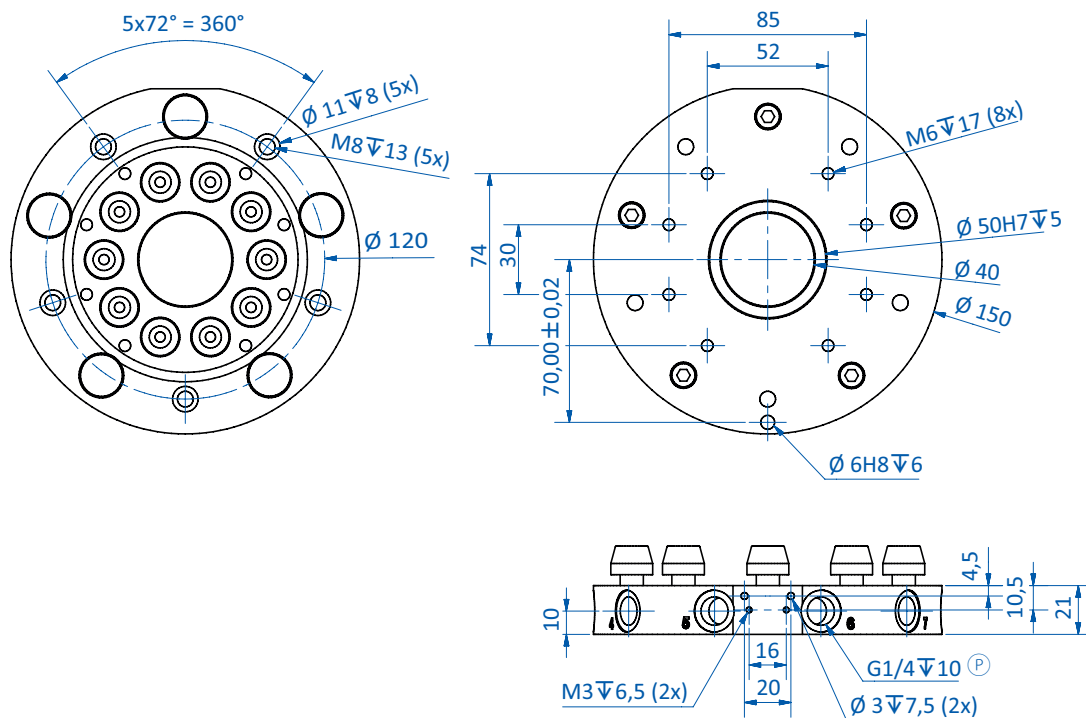

Ⓟ = Pneumatic connection



### Adapter plates for round quick-changers – gripper side



SR90-C

#### Product notes

- > Adapter plates for mounting SLine or MLine extrusions to SR Series round quick-changers
- > Slot nuts and mounting screws included in scope of delivery

#### Technical data

Item no.	Weight [g]	Suitable quick-change systems
SR50-C	107	SR50-B
SR90-C	117	SR90-B-2
SR150-C	227	SR150-B-2

#### Robot adapter plates SR Series



SR50-C



SR90-C

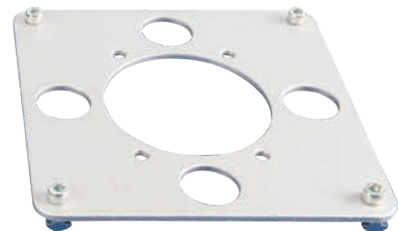

SR150-C



Dimensions

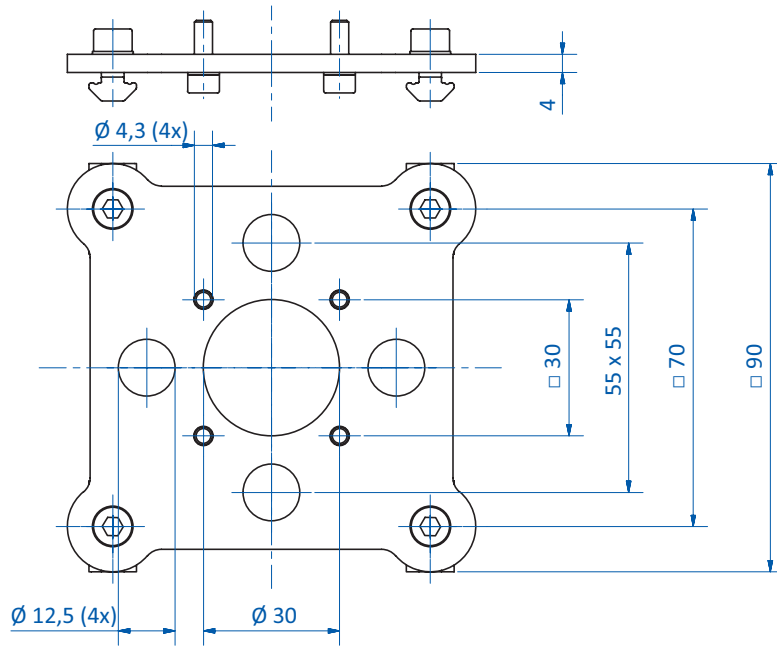

SR50-C

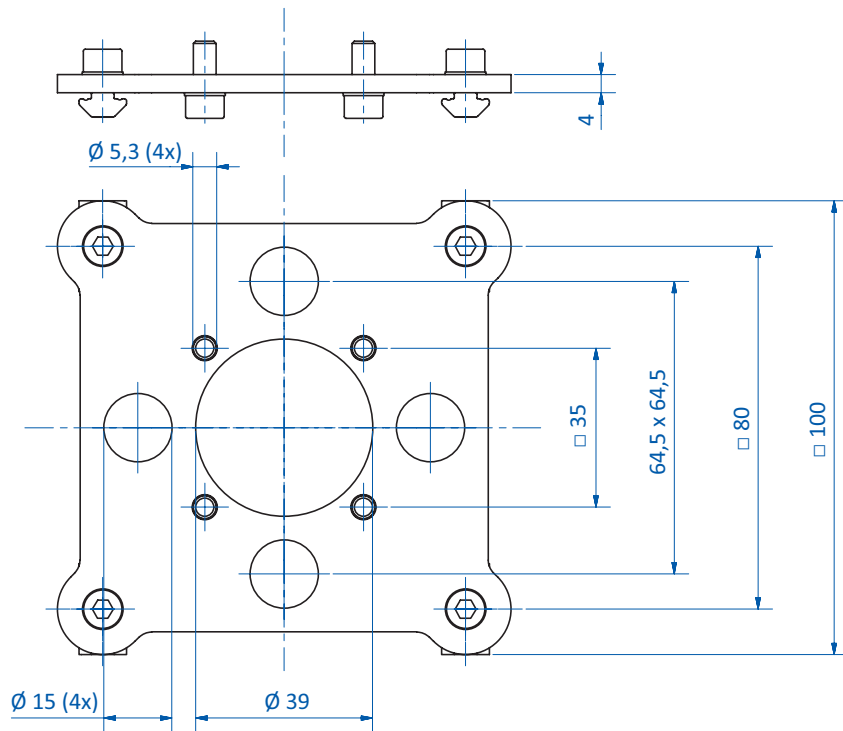

SR90-C

Continued on the next page



### Dimensions

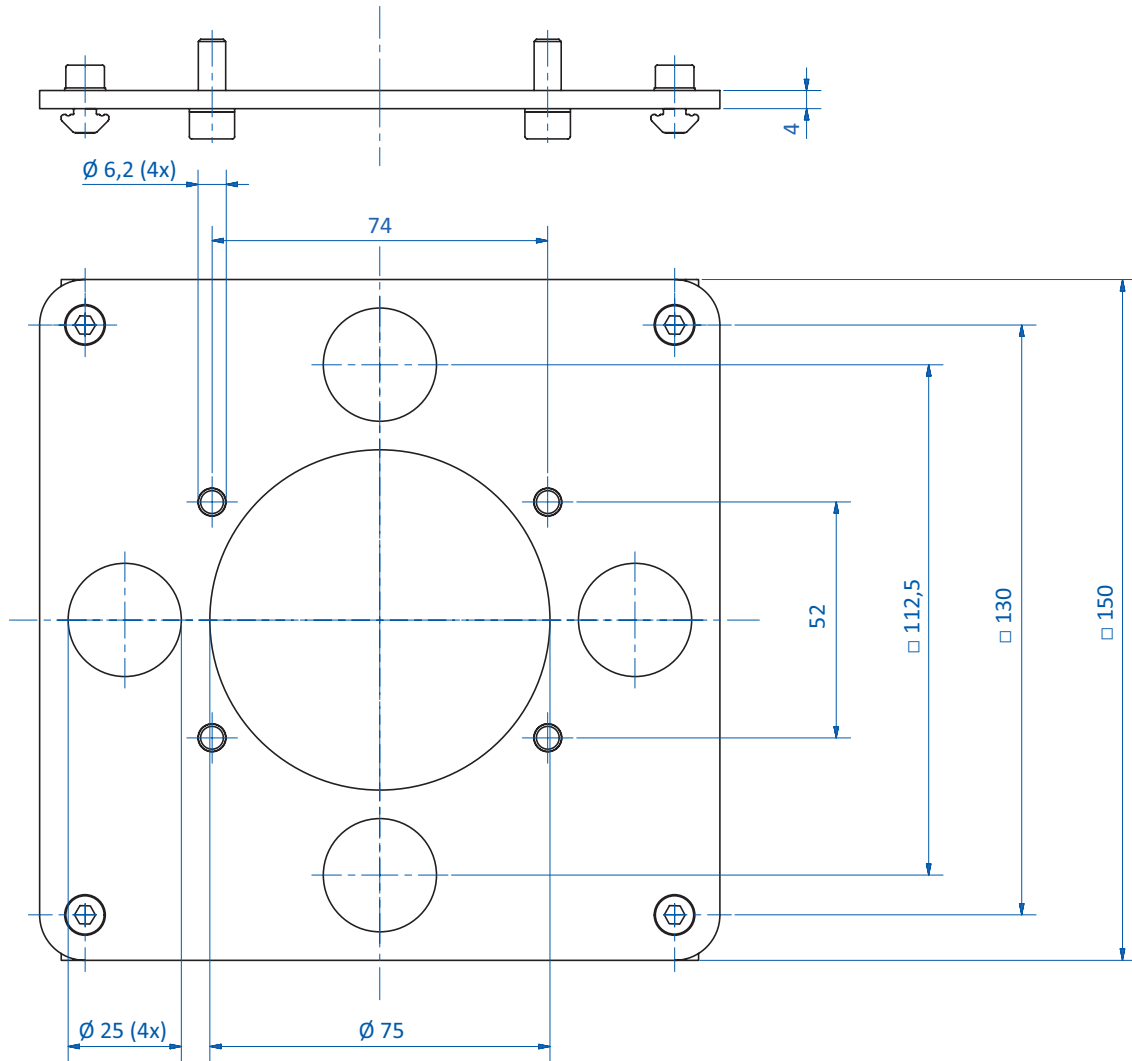

SR150-C





### Wall bracket for gripper systems with round base plate

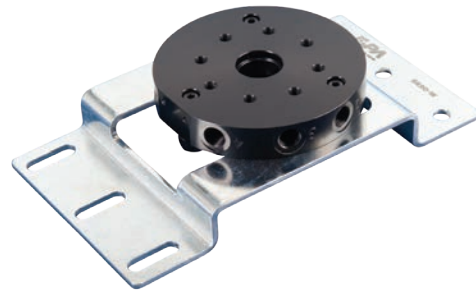

Application example with quick-changer

#### Product notes

- > Efficient and safe storage of EOAT with SR Series round quick-changers
- > Suitable for third-party round gripper systems

#### Technical data

Item no.	Weight [g]	Suitable quick-change systems
SR50-W	76	SR50-B
SR90-W	600	SR90-B-2
SR150-W	1,200	SR150-B-2

#### Dimensions

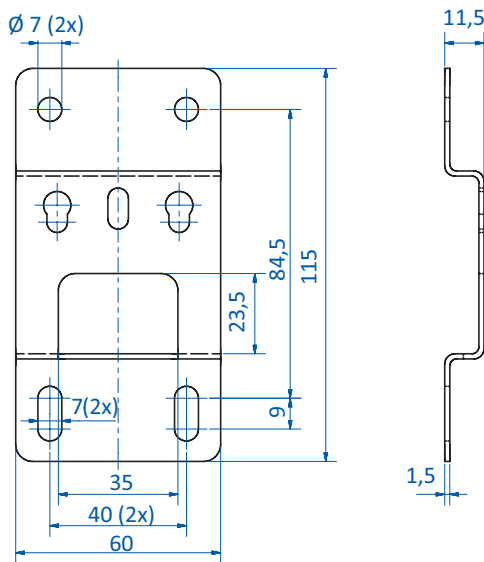

SR50-W

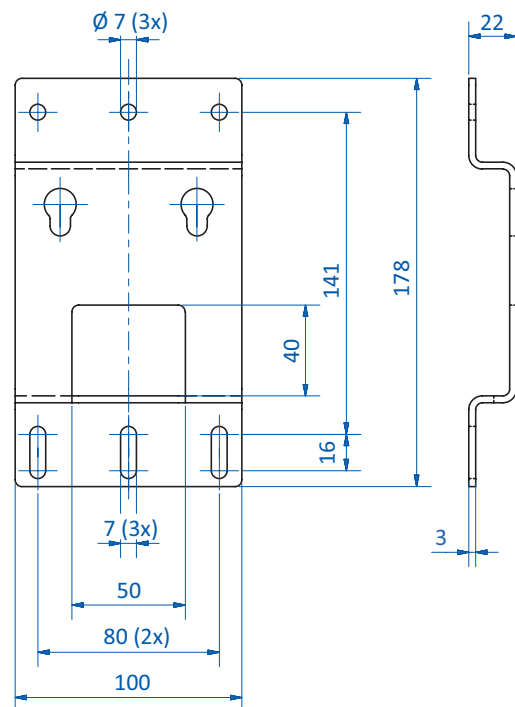

SR90-W

Continued on the next page →



Dimensions

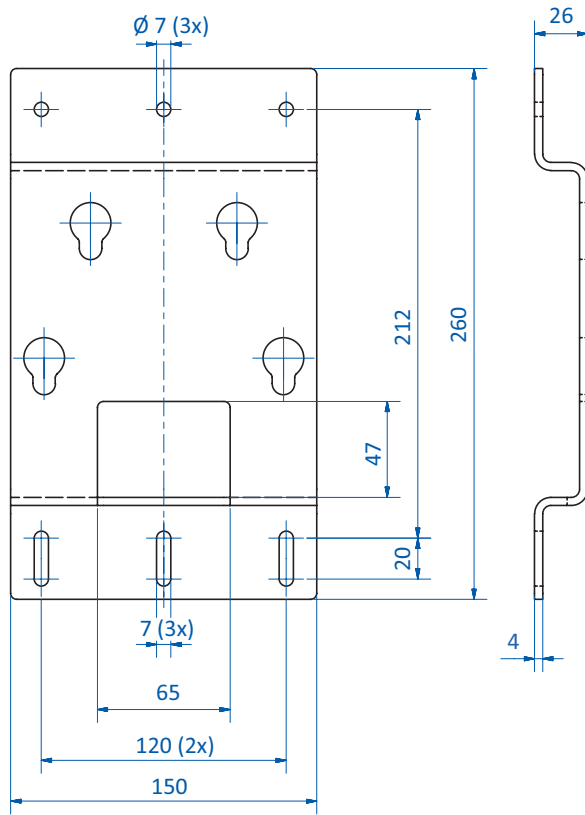

SR150-W



### Electric plug connectors for SR50, SR90 and SR150



#### Product notes

- > Electrical interface between robot and gripper
- > 9 pin SUB-D plug and 15 pin SUB-D plug
- > Max. cable cross section 0.14 mm<sup>2</sup> based on 16 - 18-wire cable
- > Suitable D-SUB connector set 20.505 for open cable ends not included in the scope of delivery
- > 20.537 and 20.538: with pre-assembled and soldered cable

#### Technical data

Item no.	Suitable quick-change systems	Type	Number of pins	Operating voltage [VDC]	Weight [g]	Suitable plug
20.535	SR90-A-2, SR90-A-MV-2, SR150-A-2, SR90-A-SL-2, SR150-A-SL-2, SR90-A-SL-MV-2	female (robot)	15	24	42	20.505
20.536	SR90-B-2, SR150-B-2	male (gripper)	15	24	41	20.505
20.537	SR50-A, SR50-A-SL, SR50-A-MV, SR50-A-SL-MV	female (robot)	9	24	42	20.505
20.538	SR50-B	male (gripper)	9	24	41	20.505

#### Wiring diagram for 20.535

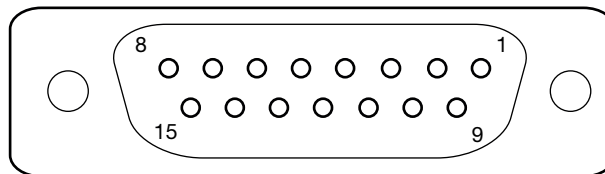

#### Wiring diagram for 20.536

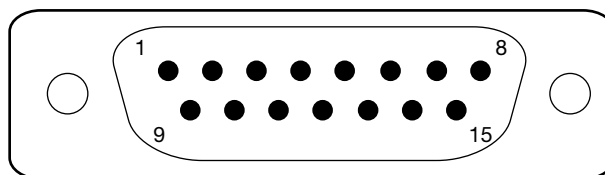

Continued on the next page →



### Wiring diagram for 20.537

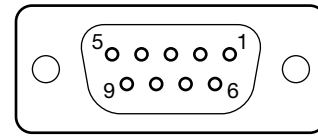
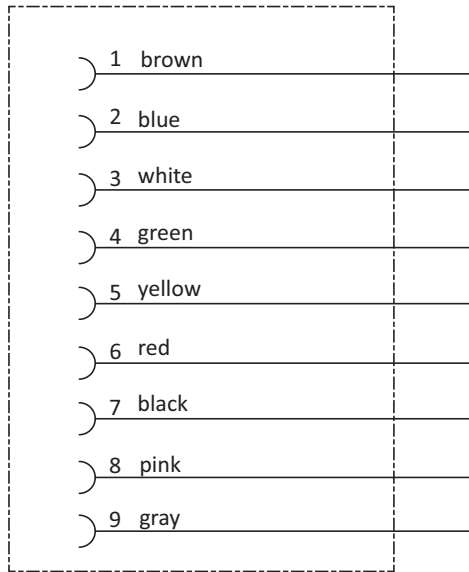

### Wiring diagram for 20.538

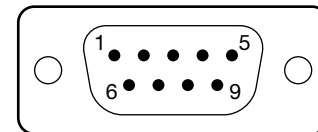
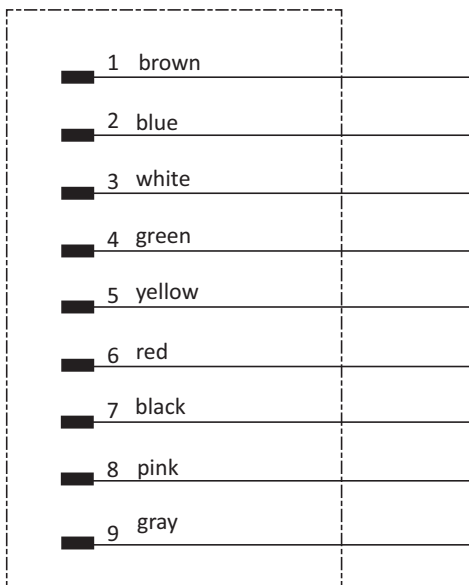

### Application example: SR Series with electric connectors 20.536





Dimensions

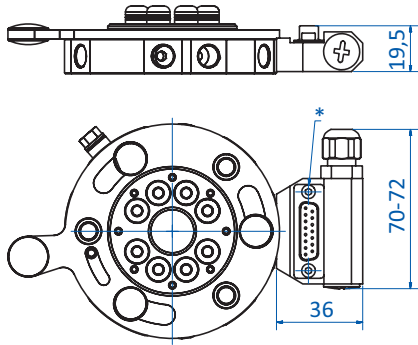

20.535 | 20.536

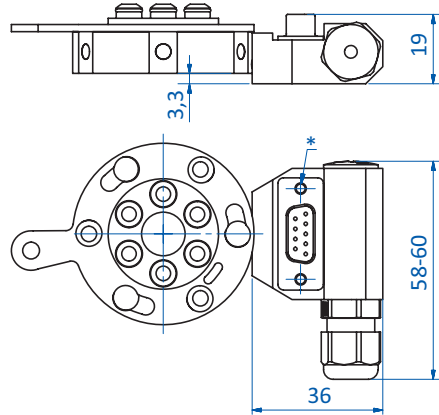

20.537 | 20.538

\* = Remove plug connection for cable installation



### Automatic quick-change system Stäubli MPS015 – robot side



#### Product notes

- > System for automatic tool change on all common industrial robots with ISO flange
- > Very precise design with a repeat accuracy of +/- 1.5 µm
- > With locking by pressure spring in case of power loss, emergency unlocking is possible
- > Sensor interrogation: locked / unlocked / coupled

#### Notes

Due to their potentially high acceleration, robots can generate dynamic moments that are several times higher than the static moments. The dynamic moments can occur in an emergency situation of the robot. Since these should only occur very rarely during the robot's service life, a static strength verification is usually sufficient for this.

#### Technical data

Item no.	ASR-MPS015R	ASR-MPS015R-PNP	ASR-MPS015R-NPN
Sensor	without	3x PNP/3x M8	3x NPN/3x M8
Compressed air connection	2x Push-lock hose-Ø 4 mm	2x Push-lock hose-Ø 4 mm	2x Push-lock hose-Ø 4 mm
Pneumatic media feedthrough	4x M5	4x M5	4x M5
Max. lifting force [kg]	10	10	10
Signal and Data transmission	M12 8-pin a-coded	M12 8-pin a-coded	M12 8-pin a-coded
Robot flange	ISO 9409-1-31.5-4-M5	ISO 9409-1-31.5-4-M5	ISO 9409-1-31.5-4-M5
Max. static moment Mx/My [Nm]	15	15	15
Max. dynamic moment Mx/My [Nm]	52	52	52
Max. static moment Mz [Nm]	15	15	15
Max. dynamic moment Mz [Nm]	52	52	52
Max. repulsion force [kN]	4	4	4
Connection force [kN]	4	4	4
Max. lateral force [kN]	2	2	2
Weight [kg]	0.26	0.32	0.32
Suitable gripper side	ASR-MPS015G	ASR-MPS015G	ASR-MPS015G

#### Dimensions

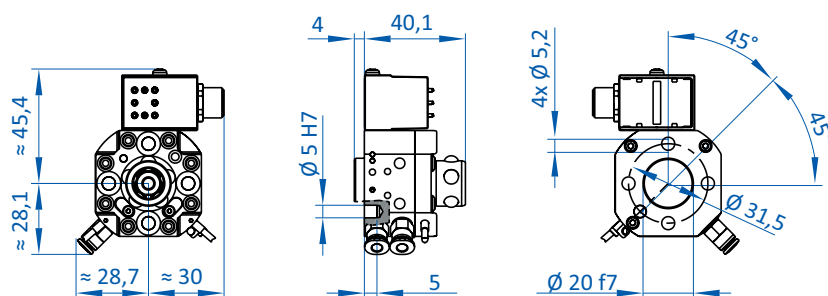



### Automatic quick-change system Stäubli MPS015 – gripper side

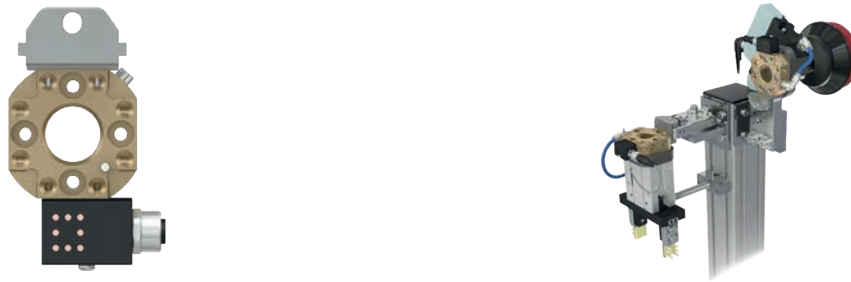

#### Product notes

- > System for automatic tool change on all common industrial robots with ISO flange
- > Very precise design with a repeat accuracy of +/- 1.5 µm
- > With locking by pressure spring in case of power loss, emergency unlocking is possible
- > With flange for storage system

#### Notes

- > The load values can be found in the data sheet for the robot side

#### Technical data

Item no.	ASR-MPS015G
Pneumatic media feedthrough	4x M5
Signal and Data transmission	M12 8-pin a-coded
Max. lifting force [kg]	10
Weight [kg]	0.22

#### Dimensions

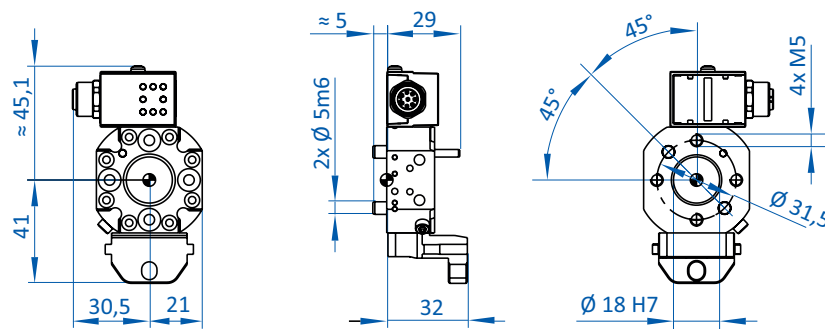



### Automatic quick-change system Stäubli MPS025 – robot side



#### Product notes

- > System for automatic tool change on all common industrial robots with ISO flange
- > Very precise design with a repeat accuracy of +/- 1.5 µm
- > With locking by pressure spring in case of power loss, emergency unlocking is possible
- > Sensor interrogation: locked / unlocked / coupled

#### Notes

Due to their potentially high acceleration, robots can generate dynamic moments that are several times higher than the static moments. The dynamic moments can occur in an emergency situation of the robot. Since these should only occur very rarely during the robot's service life, a static strength verification is usually sufficient for this.

#### Technical data

Item no.	ASR-MPS025R	ASR-MPS025R-PNP	ASR-MPS025R-NPN
Sensor	without	3x PNP/3x M8	3x NPN/3x M8
Compressed air connection	2x Push-lock hose-Ø 4 mm	2x Push-lock hose-Ø 4 mm	2x Push-lock hose-Ø 4 mm
Pneumatic media feedthrough	4x M5	4x M5	4x M5
Max. lifting force [kg]	20	20	20
Signal and Data transmission	M12 8-pin a-coded	M12 8-pin a-coded	M12 8-pin a-coded
Robot flange	ISO 9409-1-40-4-M6	ISO 9409-1-40-4-M6	ISO 9409-1-40-4-M6
Max. static moment Mx/My [Nm]	34	34	34
Max. dynamic moment Mx/My [Nm]	119	119	119
Max. static moment Mz [Nm]	34	34	34
Max. dynamic moment Mz [Nm]	119	119	119
Max. repulsion force [kN]	6	6	6
Connection force [kN]	6	6	6
Max. lateral force [kN]	2	2	2
Weight [kg]	0.37	0.44	0.44
Suitable gripper side	ASR-MPS025G	ASR-MPS025G	ASR-MPS025G

#### Dimensions

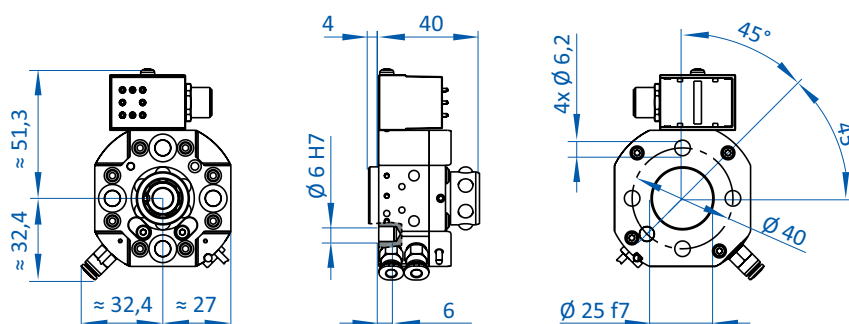





### Automatic quick-change system Stäubli MPS025 – gripper side

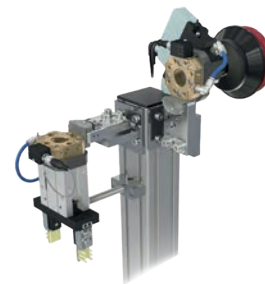
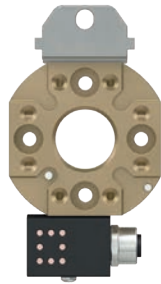

#### Product notes

- > System for automatic tool change on all common industrial robots with ISO flange
- > Very precise design with a repeat accuracy of +/- 1.5 µm
- > With locking by pressure spring in case of power loss, emergency unlocking is possible
- > With flange for storage system

#### Notes

- > The load values can be found in the data sheet for the robot side

#### Technical data

<b>Item no.</b>	<b>ASR-MPS025G</b>
<b>Pneumatic media feedthrough</b>	4x M5
<b>Signal and Data transmission</b>	M12 8-pin a-coded
<b>Max. lifting force [kg]</b>	20
<b>Weight [kg]</b>	0.26

#### Dimensions

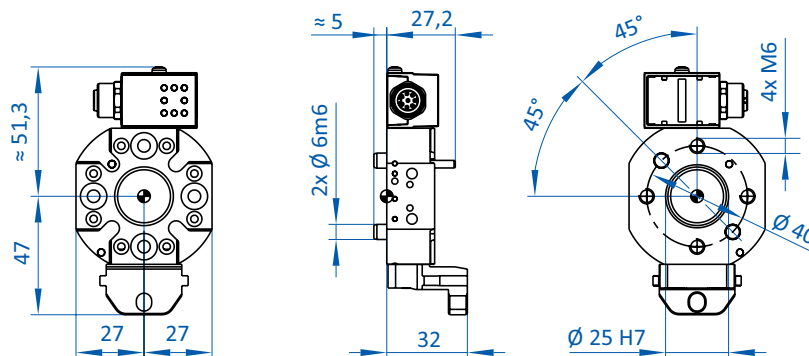



### Automatic quick-change system Stäubli MPS035 – robot side



#### Product notes

- > System for automatic tool change on all common industrial robots with ISO flange
- > Very precise design with a repeat accuracy of +/- 1.5 µm
- > With locking by pressure spring in case of power loss, emergency unlocking is possible
- > Sensor interrogation: locked / unlocked / coupled

#### Notes

Due to their potentially high acceleration, robots can generate dynamic moments that are several times higher than the static moments. The dynamic moments can occur in an emergency situation of the robot. Since these should only occur very rarely during the robot's service life, a static strength verification is usually sufficient for this.

#### Technical data

Item no.	ASR-MPS035R	ASR-MPS035R-PNP	ASR-MPS035R-NPN
Sensor	without	3x PNP/3x M8	3x NPN/3x M8
Compressed air connection	2x Push-lock hose-Ø 4 mm	2x Push-lock hose-Ø 4 mm	2x Push-lock hose-Ø 4 mm
Pneumatic media feedthrough	5x G1/8	5x G1/8	5x G1/8
Max. lifting force [kg]	35	35	35
Signal and Data transmission	M12 8-pin a-coded	M12 8-pin a-coded	M12 8-pin a-coded
Robot flange	ISO 9409-1-50-4-M6	ISO 9409-1-50-4-M6	ISO 9409-1-50-4-M6
Max. static moment Mx/My [Nm]	80	80	80
Max. dynamic moment Mx/My [Nm]	280	280	280
Max. static moment Mz [Nm]	80	80	80
Max. dynamic moment Mz [Nm]	280	280	280
Max. repulsion force [kN]	10	10	10
Connection force [kN]	10	10	10
Max. lateral force [kN]	5	5	5
Weight [kg]	0.5	0.56	0.56
Suitable gripper side	ASR-MPS035G	ASR-MPS035G	ASR-MPS035G

#### Dimensions

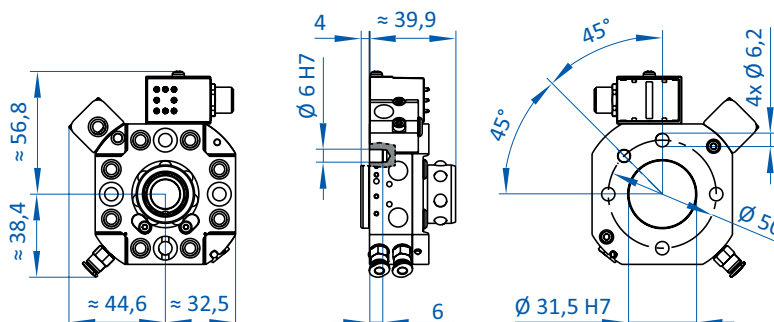



### Automatic quick-change system Stäubli MPS035 – gripper side



#### Product notes

- > System for automatic tool change on all common industrial robots with ISO flange
- > Very precise design with a repeat accuracy of +/- 1.5 µm
- > With locking by pressure spring in case of power loss, emergency unlocking is possible
- > With flange for storage system

#### Notes

- > The load values can be found in the data sheet for the robot side

#### Technical data

<b>Item no.</b>	<b>ASR-MPS035G</b>
<b>Pneumatic media feedthrough</b>	5x G1/8
<b>Signal and Data transmission</b>	M12 8-pin a-coded
<b>Max. lifting force [kg]</b>	35
<b>Weight [kg]</b>	0.38

#### Dimensions

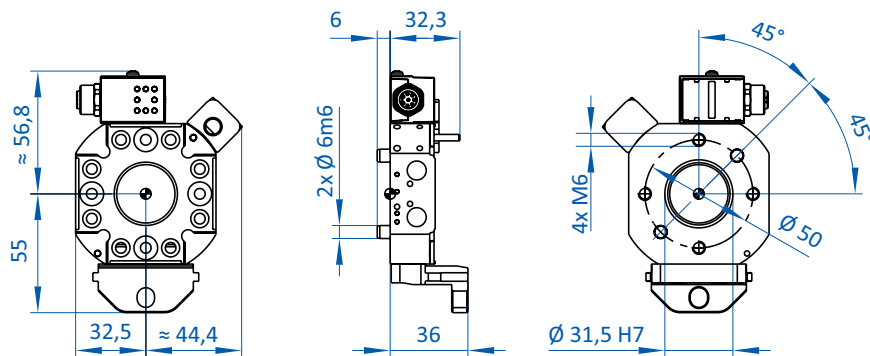



# Quick-change systems | MPS Series

Automatic quick-change system Stäubli MPS055 – robot side

## Automatic quick-change system Stäubli MPS055 – robot side

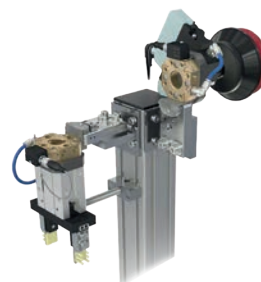
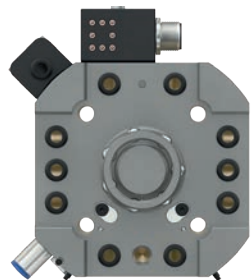

### Product notes

- > System for automatic tool change on all common industrial robots with ISO flange
- > Very precise design with a repeat accuracy of +/- 1.5 µm
- > With locking by pressure spring in case of power loss, emergency unlocking is possible
- > Sensor interrogation: locked / unlocked / coupled

### Notes

Due to their potentially high acceleration, robots can generate dynamic moments that are several times higher than the static moments. The dynamic moments can occur in an emergency situation of the robot. Since these should only occur very rarely during the robot's service life, a static strength verification is usually sufficient for this.

### Technical data

Item no.	ASR-MPS055R	ASR-MPS055R-PNP	ASR-MPS055R-NPN
Sensor	without	3x PNP/3x M8	3x NPN/3x M8
Compressed air connection	2x Push-lock hose-Ø 6 mm	2x Push-lock hose-Ø 6 mm	2x Push-lock hose-Ø 6 mm
Pneumatic media feedthrough	5x G1/8	5x G1/8	5x G1/8
Max. lifting force [kg]	55	55	55
Signal and Data transmission	M12 8-pin a-coded	M12 8-pin a-coded	M12 8-pin a-coded
Robot flange	ISO 9409-1-63-4-M6	ISO 9409-1-63-4-M6	ISO 9409-1-63-4-M6
Max. static moment Mx/My [Nm]	145	145	145
Max. dynamic moment Mx/My [Nm]	507	507	507
Max. static moment Mz [Nm]	106	106	106
Max. dynamic moment Mz [Nm]	371	371	371
Max. repulsion force [kN]	12	12	12
Connection force [kN]	12	12	12
Max. lateral force [kN]	6.5	6.5	6.5
Weight [kg]	0.9	0.96	0.96
Suitable gripper side	ASR-MPS055G	ASR-MPS055G	ASR-MPS055G

### Dimensions

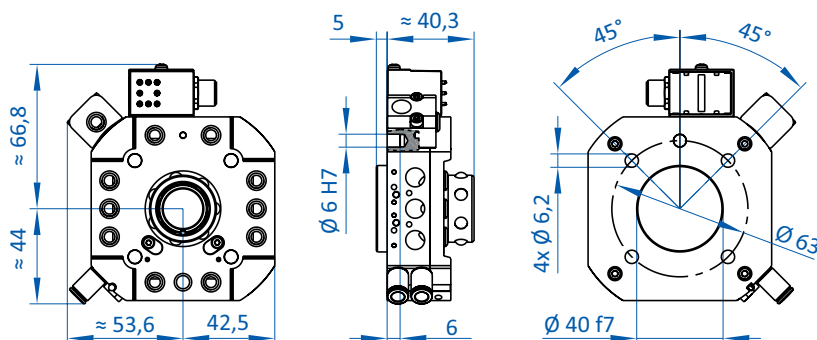



### Automatic quick-change system Stäubli MPS055 – gripper side



#### Product notes

- > System for automatic tool change on all common industrial robots with ISO flange
- > Very precise design with a repeat accuracy of +/- 1.5 µm
- > With locking by pressure spring in case of power loss, emergency unlocking is possible
- > With flange for storage system

#### Notes

- > The load values can be found in the data sheet for the robot side

#### Technical data

Item no.	ASR-MPS055G
Pneumatic media feedthrough	5x G1/8
Signal and Data transmission	M12 8-pin a-coded
Max. lifting force [kg]	55
Weight [kg]	0.49

#### Dimensions

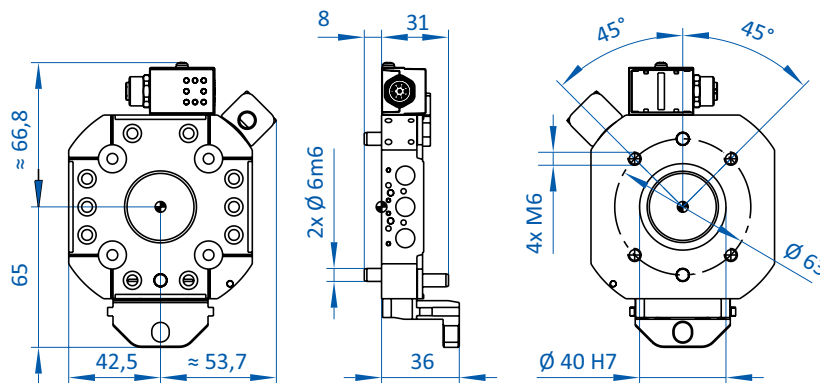



<b>Extrusions</b> .....	<b>46</b>
<b>Slot nuts</b> .....	<b>55</b>
<b>Connectors</b> .....	<b>62</b>
<b>Clamps for shafts</b> .....	<b>80</b>
<b>Mounting of vacuum cups</b> .....	<b>98</b>
<b>Air manifolds</b> .....	<b>103</b>
<b>Accessories</b> .....	<b>106</b>



### SLine extrusions



#### Product notes

- > Lightweight and rigid
- > Special lengths over 2,000 mm on request

#### Technical data

Item no.	Length [mm]	Cross-section area [cm <sup>2</sup> ]	Second moment of area axial Ix [cm <sup>4</sup> ]	Second moment of area axial Iy [cm <sup>4</sup> ]	Section modulus axial Wx [cm <sup>3</sup> ]	Section modulus axial Wy [cm <sup>3</sup> ]	Weight [kg/m]	Suitable end caps
GR01.001.2000	1,960	1.28	0.12	0.53	0.22	0.53	0.35	GR01.010
GR01.002.2000	1,960	2.34	0.24	3.59	0.45	1.8	0.63	GR01.011
GR01.003.2000	1,960	1.8	0.74	0.74	0.74	0.74	0.48	GR01.012
GR01.004.2000	1,960	3.22	1.39	5.16	1.39	2.53	0.87	GR01.013
GR01.006.2000	1,960	6.06	2.68	35.8	2.68	8.95	1.67	GR01.015
GR01.007.2000	1,960	4.94	9.16	9.16	4.53	4.53	1.33	GR01.016

#### Dimensions

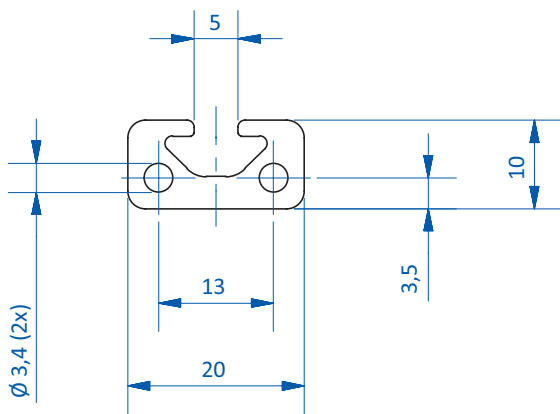

GR01.001.2000

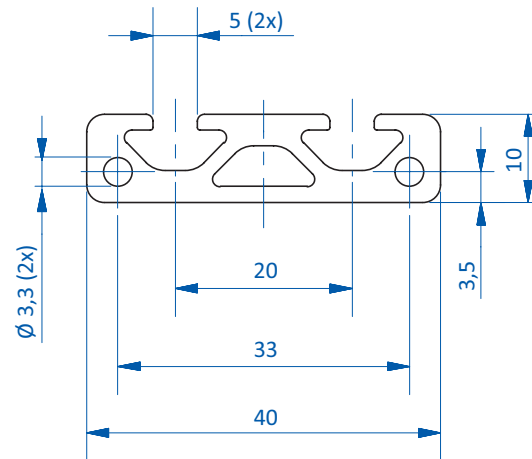

GR01.002.2000





Dimensions

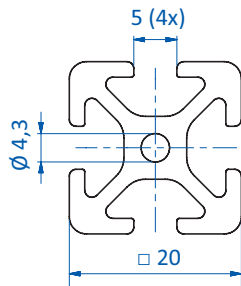

GR01.003.2000

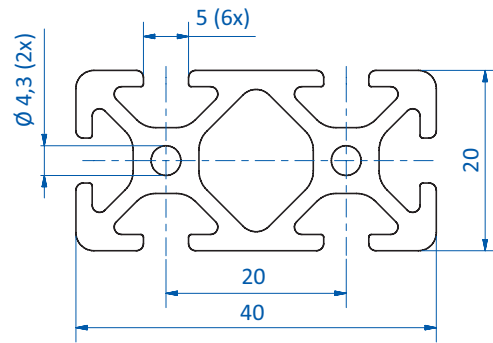

GR01.004.2000

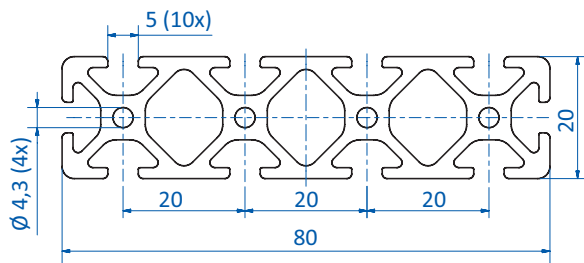

GR01.006.2000

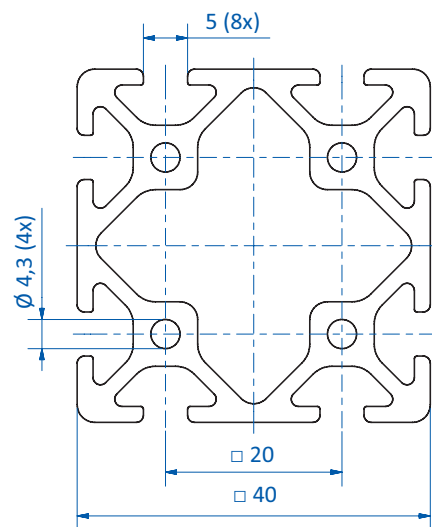

GR01.007.2000



### MLine and JLine extrusions



#### Product notes

- > Lightweight and rigid
- > Special lengths over 2,000 mm on request

#### Technical data

Item no.	GR01.008.2000	GR01.009.2000	GR01.160.2000	GR01.161.2000
Extrusion system	MLine	MLine	JLine	JLine
Length [mm]	2,000	2,000	2,000	2,000
Cross-section area [cm <sup>2</sup> ]	2.48	4.27	5.19	8.85
Second moment of area axial I <sub>x</sub> [cm <sup>4</sup> ]	1.58	10.89	8.66	15.52
Second moment of area axial I <sub>y</sub> [cm <sup>4</sup> ]	1.58	2.85	8.66	5.86
Section modulus axial W <sub>x</sub> [cm <sup>3</sup> ]	1.26	4.36	4.32	14.56
Section modulus axial W <sub>y</sub> [cm <sup>3</sup> ]	1.26	2.28	4.32	7.75
Weight [kg/m]	0.61	1.04	1.4	2.4
Suitable end caps	GR01.017	GR01.018	GR01.162	GR01.163

#### Dimensions

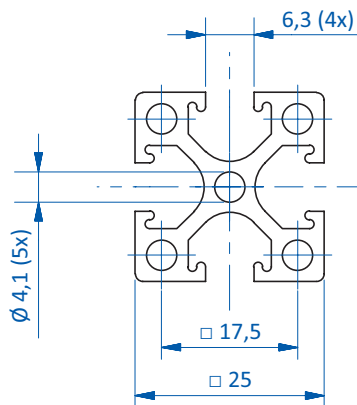

GR01.008.2000



Dimensions

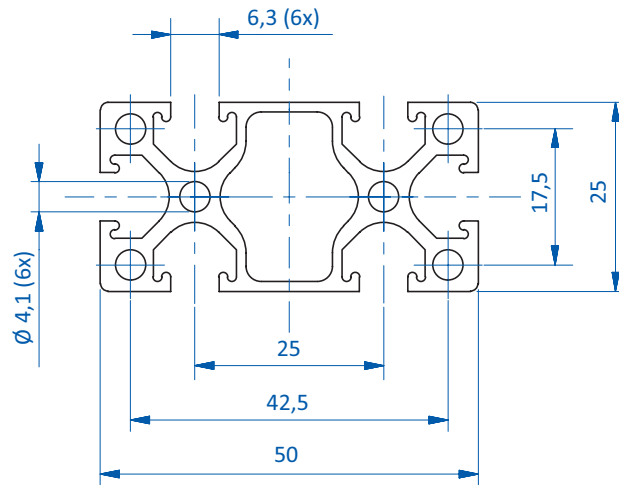

GR01.009.2000

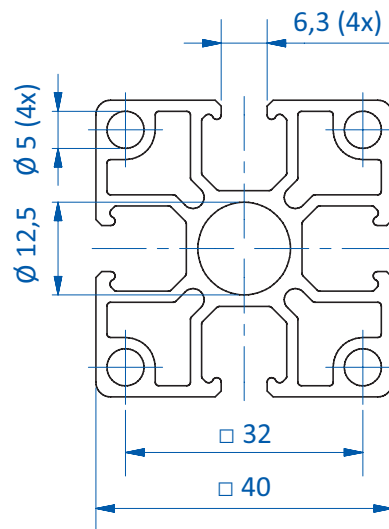

GR01.160.2000

Continued on the next page →



## Dimensions

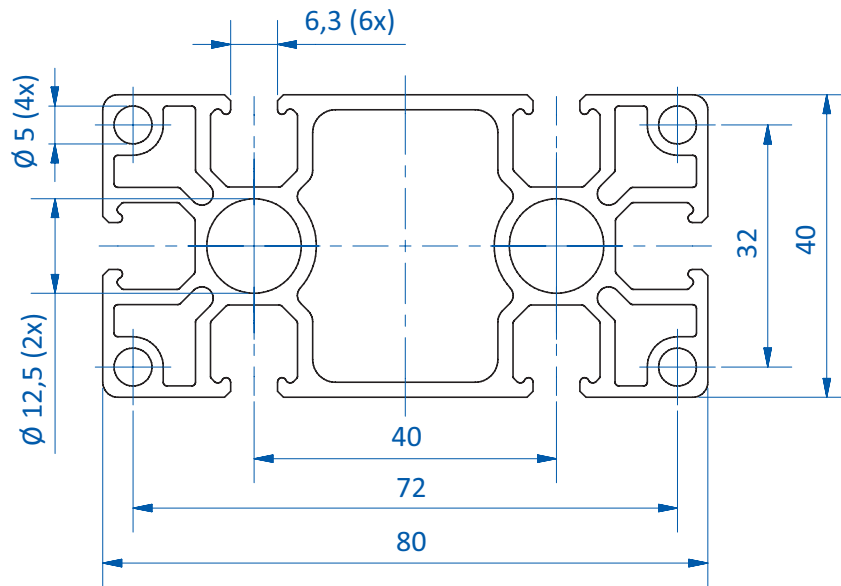

GR01.161.2000



XLine extrusions



Product notes

- > High rigidity
- > Special lengths over 2,000 mm on request

Technical data

Item no.	Length [mm]	Cross-section area [cm <sup>2</sup> ]	Second moment of area axial Ix [cm <sup>4</sup> ]	Second moment of area axial Iy [cm <sup>4</sup> ]	Section modulus axial Wx [cm <sup>3</sup> ]	Section modulus axial Wy [cm <sup>3</sup> ]	Weight [kg/m]	Suitable end caps
GR-XL01.003.2000	1,960	5.04	7.34	7.34	3.67	3.67	1.36	GR-XL01.012
GR-XL01.004.2000	1,960	8.73	14.7	57.7	7.37	14.4	2.37	GR-XL01.013
GR-XL01.005.2000	1,960	19.2	131	131	32.8	32.8	5.19	--

Dimensions

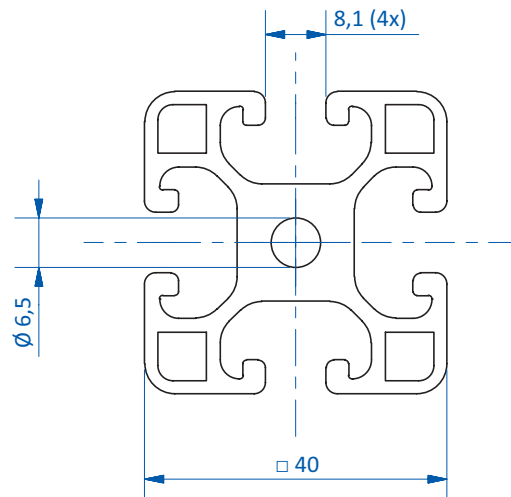

GR-XL01.003.2000

Continued on the next page →



Dimensions

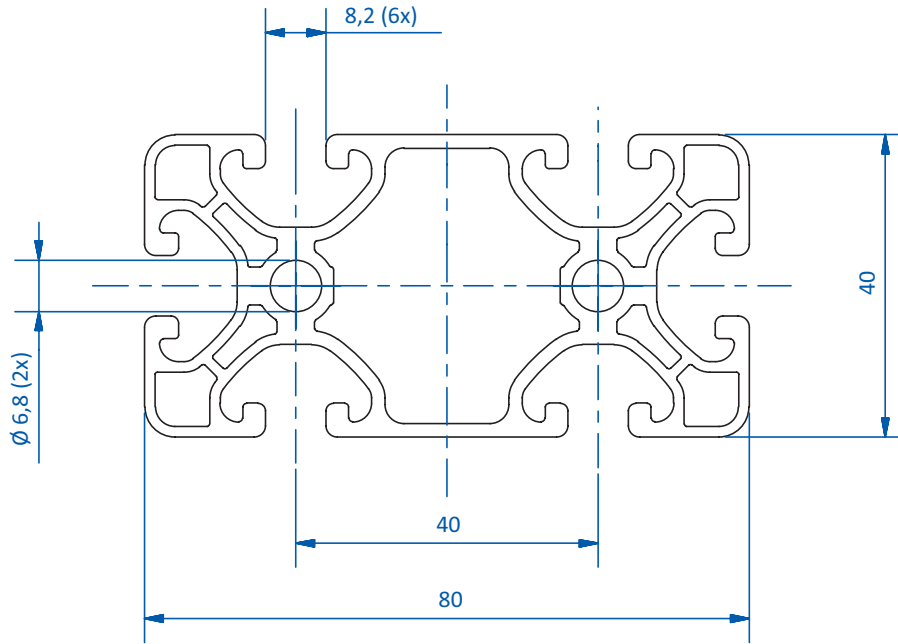

GR-XL01.004.2000

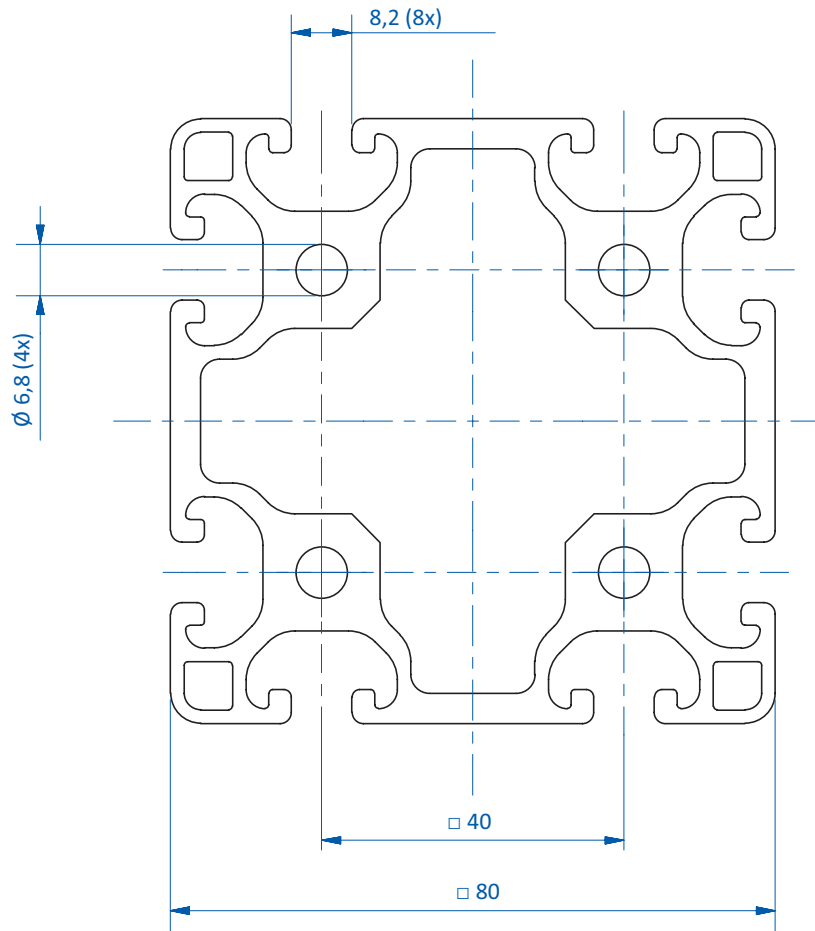

GR-XL01.005.2000



End caps



**Product notes**

- > Edge protection, for installation at the end of extrusion
- > Material: PA6 black

**Technical data**

Item no.	Suitable for extrusion system	Suitable for extrusion size [mm]
GR01.010	SLine	10x20
GR01.011	SLine	10x40
GR01.012	SLine	20x20
GR01.013	SLine	20x40
GR01.015	SLine	20x80
GR01.016	SLine	40x40
GR01.017	MLine	25x25
GR01.018	MLine	25x50
GR01.162	JLine	40x40
GR01.163	JLine	40x80
GR-XL01.012	XLine	40x40
GR-XL01.013	XLine	40x80

**Application examples**



Continued on the next page →



### Dimensions

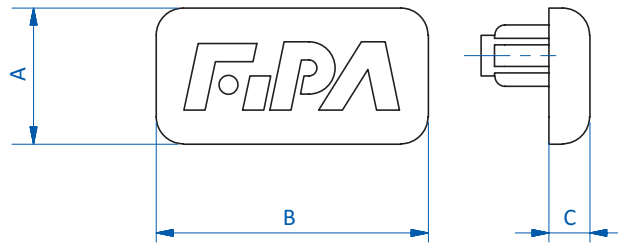

Item no.	A [mm]	B [mm]	C [mm]
GR01.010	10	20	3
GR01.011	10	40	3
GR01.012	20	20	3
GR01.013	20	40	3
GR01.015	20	80	3
GR01.016	40	40	3
GR01.017	25	25	3
GR01.018	25	50	3
GR01.162	40	40	4
GR01.163	40	80	4
GR-XL01.012	40	40	4
GR-XL01.013	40	80	4





### Threaded slot nuts



#### Product notes

- > Galvanized steel slot nuts
- > Ball catch prevents slipping of slot nut during installation
- > Compatible with many third-party extrusions

#### Technical data

Item no.	Suitable for extrusion system	With ball catch	Weight [g]
GR01.088A	SLine / MLine	No	2
GR01.089A	SLine / MLine	No	3
GR01.090A	SLine / MLine	No	6
GR01.091A	SLine / MLine	Yes	6
GR01.092A	SLine / MLine	Yes	8
GR01.093A	SLine / MLine	Yes	9
GR01.094A	SLine / MLine	Yes	12
GR01.095A	SLine / MLine	Yes	13
GR01.096A	SLine / MLine	Yes	20
GR01.097A	SLine / MLine	No	2
GR01.098A	SLine / MLine	No	5
GR01.101A	SLine / MLine	Yes	12
GR01.102A	SLine / MLine	Yes	20
GR01.103	MLine	Yes	4
GR01.104	MLine	No	7
GR01.105	MLine	No	16
GR-XL01.100	XLine	Yes	17
GR-XL01.101	XLine	Yes	21
GR-XL01.102	XLine	Yes	35
GR-XL01.103	XLine	Yes	57
GR-XL01.104	XLine	Yes	94
GR-XL01.106	XLine	Yes	18

Continued on the next page →



### Dimensions

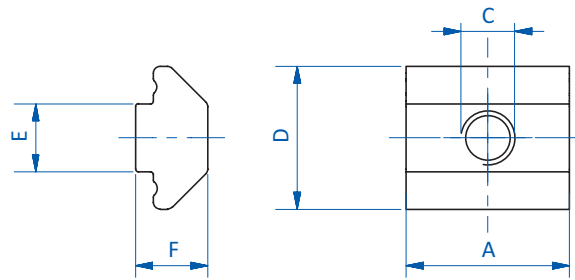

GR01.088A | GR01.089A | GR01.097A | GR01.098A | GR-XL01.100 | GR-XL01.106

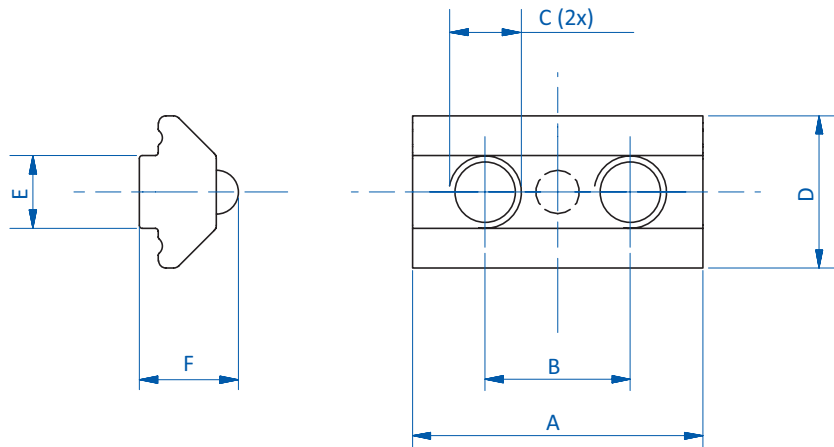

GR01.090A | GR01.091A | GR01.092A | GR01.093A | GR01.094A | GR01.095A | GR01.096A | GR01.101A | GR01.102A | GR-XL01.101 | GR-XL01.102 | GR-XL01.103 | GR-XL01.104

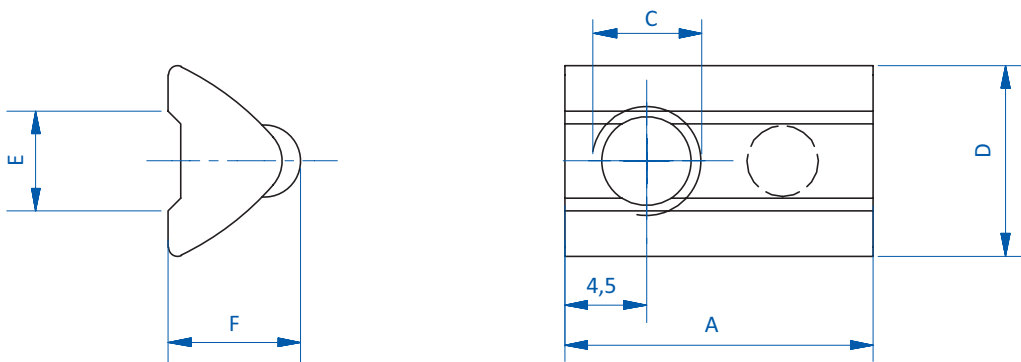

GR01.103

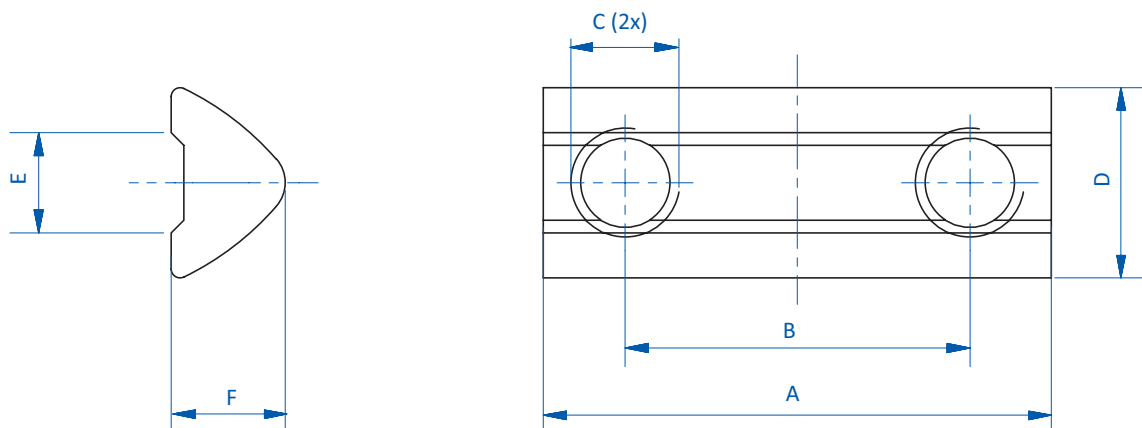

GR01.104 | GR01.105



Item no.	C	A [mm]	B [mm]	D [mm]	E [mm]	F [mm]
GR01.088A	M3	12	--	10.5	4.5	5.3
GR01.089A	M4	12	--	10.5	4.5	5.3
GR01.090A	M4	20	8	10.5	5	6.8
GR01.091A	M5	20	10	10.5	5	6.8
GR01.092A	M5	25	12	10.5	5	6.8
GR01.093A	M5	30	20	10.5	5	6.8
GR01.094A	M5	35	25	10.5	5	6.8
GR01.095A	M5	40	30	10.5	5	6.8
GR01.096A	M5	60	50	10.5	5	6.8
GR01.097A	M5	12	--	10.5	5	6.8
GR01.098A	M5	20	--	10.5	5	6.8
GR01.101A	M5	45	35	10.5	5	6.8
GR01.102A	M5	70	60	10.5	5	6.8
GR01.103	M6	17	--	10.5	5.5	7.3
GR01.104	M6	28	17	10.5	5.5	6.3
GR01.105	M6	58	47	10.5	5.5	6.3
GR-XL01.100	M8	22	--	17	8	12.1
GR-XL01.101	M8	30	15	17	8	12.1
GR-XL01.102	M8	45	30	17	8	12.1
GR-XL01.103	M8	70	55	17	8	12.1
GR-XL01.104	M8	110	95	17	8	12.1
GR-XL01.106	M6	22	--	17	8	12.1



### Threaded slot nuts – swivel-in



#### Product notes

- > Galvanized steel slot nuts
- > Enables subsequent extension of gripper systems without disassembly
- > Ball catch prevents slipping of slot nut during installation

#### Technical data

Item no.	Suitable for extrusion system	With ball catch	Weight [g]
GR01.069	SLine	Yes	2
GR01.070	SLine	Yes	2
GR01.071	SLine	Yes	2
GR01.080	SLine	No	2
GR01.081	SLine	Yes	3
GR01.082	SLine	Yes	4
GR01.084	SLine	Yes	6
GR01.085	SLine	Yes	7
GR01.086	SLine	Yes	11
GR-XL01.105	XLine	Yes	8

#### Dimensions

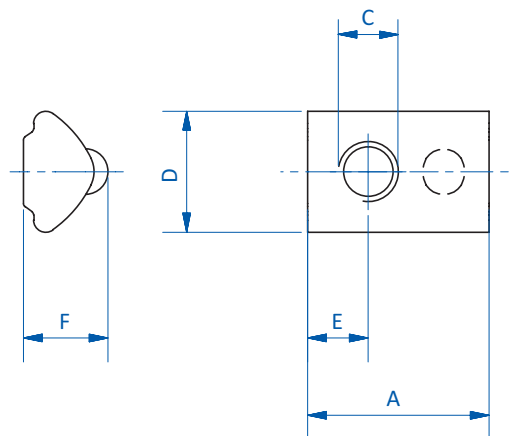

GR01.069 | GR01.070 | GR01.071 | GR-XL01.105



Dimensions

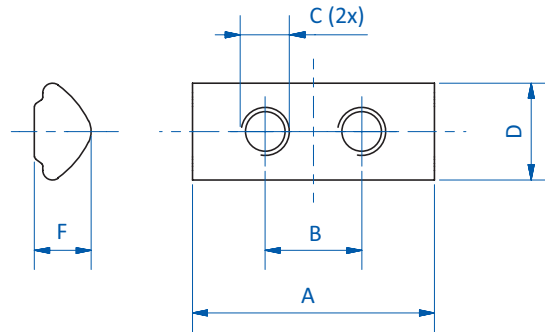

GR01.080

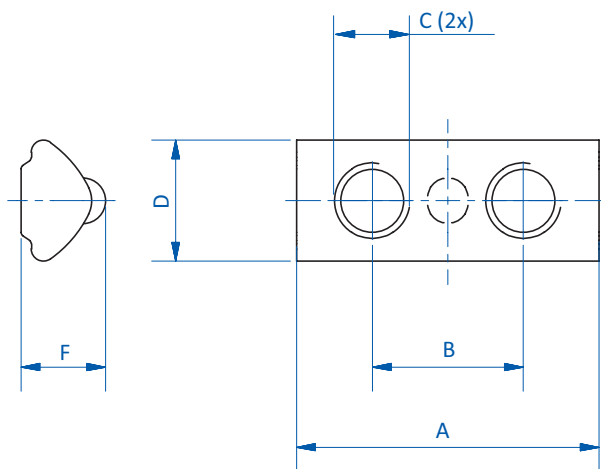

GR01.081 | GR01.082 | GR01.084 | GR01.085 | GR01.086

Item no.	C	A [mm]	B [mm]	D [mm]	F [mm]	E [mm]
GR01.069	M3	12	--	8	5.6	3
GR01.070	M4	12	--	8	5.6	4
GR01.071	M5	12	--	8	5.6	4
GR01.080	M4	20	8	8	4.7	--
GR01.081	M5	20	10	8	5.6	--
GR01.082	M5	25	12	8	5.6	--
GR01.084	M5	35	25	8	5.6	--
GR01.085	M5	40	30	8	5.6	--
GR01.086	M5	60	50	8	5.6	--
GR-XL01.105	M5	22	--	12.9	9.1	6.3



### Threaded slot nuts – MLine and JLine



#### Product notes

- > Mount custom components to MLine or JLine profile based grippers
- > Single or double metric threads available

#### Technical data

Item no.	Weight [g]
GR01.17.4	6
GR01.17.4.008	6
GR01.17.4.017	10
GR01.17.5	6
GR01.17.5.010	6
GR01.17.5.012	9
GR01.17.5.015	9
GR01.17.5.020	11
GR01.17.5.022	12
GR01.17.5.025	13
GR01.17.5.028	15
GR01.17.5.030	16
GR01.17.5.035	18
GR01.17.5.038	19
GR01.17.5.040	19
GR01.17.5.050	23
GR01.17.5.060	27
GR01.17.6	6
GR01.17.6.020	11
GR01.17.6.025	13
GR01.17.6.035	17
GR01.17.6.040	19
GR01.17.6.050	23
GR01.17.6.090	40

#### Dimensions

C	A [mm]	B [mm]
M4	8	0
M4	16	8
M4	25	17
M5	10	0
M5	20	10
M5	22	12
M5	25	15
M5	30	20
M5	32	22
M5	33	25
M5	38	28
M5	40	30
M5	45	35
M5	48	38
M5	50	40
M5	60	50
M5	70	60
M6	10	0
M6	30	20
M6	35	25
M6	45	35
M6	50	40
M6	60	50
M6	100	90



## Dimensions

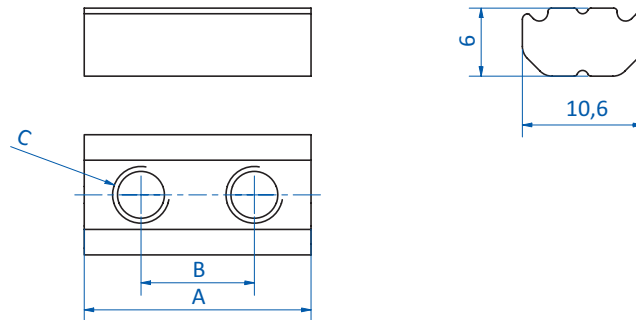



### Cross joint connectors – standard



#### Product notes

- > Elements for 90° connection of two extrusions
- > Long groove for more rigid joints

#### Technical data

Item no.	Profile 1	Profile 2	Weight [g]
GR01.201	M25	L18	85
GR01.202	M25	M25	81
GR01.203	M50	M25	133
GR01.204	M50	M50	187
GR01.205	J40	M25	131
GR01.206	J40	J40	115
GR01.207	M25	J80	180
GR01.208	J40	J80	195
GR01.209	J80	J80	302
GR-XL01.020	X40	X40	218
GR-XL01.021	X40	X80	380
GR-XL01.022	X80	X80	630

#### Dimensions

A [mm]	B [mm]	C [mm]	D [mm]	E [mm]	F [mm]	G [mm]
18	25	24	13	45	45	4
25	25	24	13	45	45	4
50	25	24	13	50	70	4
50	50	24	13	70	70	4
40	25	24	13	60	60	4
40	40	24	13	60	60	4
25	80	24	13	50	100	4
40	80	24	13	60	100	4
80	80	24	13	100	100	4
40	40	30	12	70	70	4
40	80	30	12	70	110	4
80	80	30	12	110	110	4

#### Dimensions

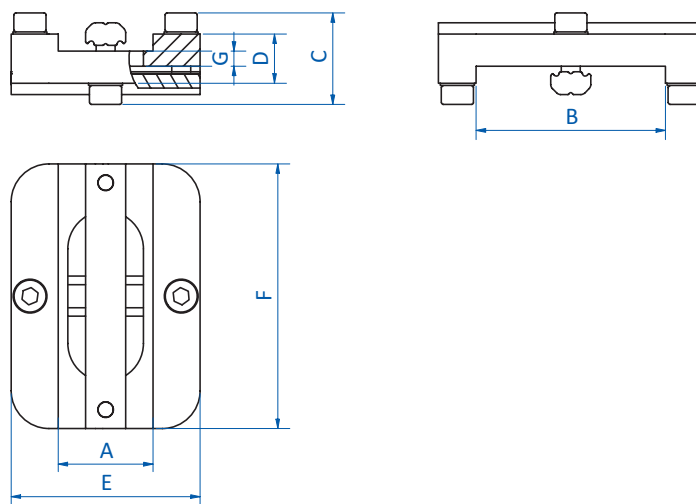





### Cross joint connectors – narrow



#### Product notes

- > Elements for 90° connection of two extrusions
- > Long groove for more rigid joints

#### Technical data

Item no.	Profile 1	Profile 2	Weight [g]
GR01.020A	S20	S20	48
GR01.021	S20	S40	73
GR01.022	S40	S40	107
GR01.023	S20	M25	61
GR01.024	S20	X40	119
GR01.025	S40	X40	173
GR01.026	M25	M25	55
GR01.027	M25	M50	90
GR01.150	M50	M50	101

#### Dimensions

A [mm]	B [mm]	C [mm]	D [mm]	E [mm]	F [mm]
20	20	20	9	40	40
20	40	20	9	40	60
40	40	20	9	60	60
20	25	23	12	40	45
20	40	27	12	50	60
40	40	27	12	70	60
25	25	23	12	45	45
25	50	23	12	45	70
50	50	23	12	70	70

Continued on the next page →



### Dimensions

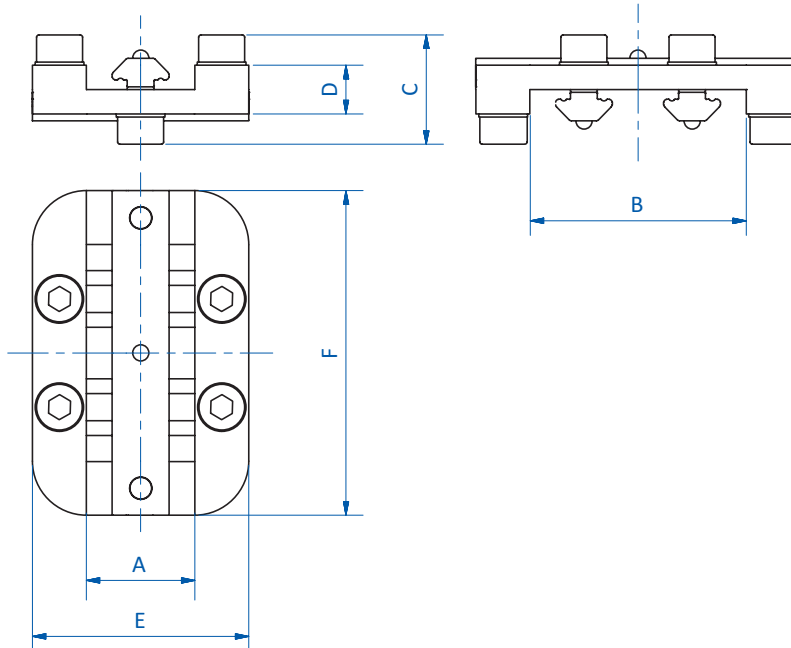



### Cross joint connectors – basic



#### Product notes

> Ideal of joining two profiles

#### Technical data

Item no.	Profile 1	Profile 2	Weight [g]
GR01.029	M25	M25	64

#### Dimensions

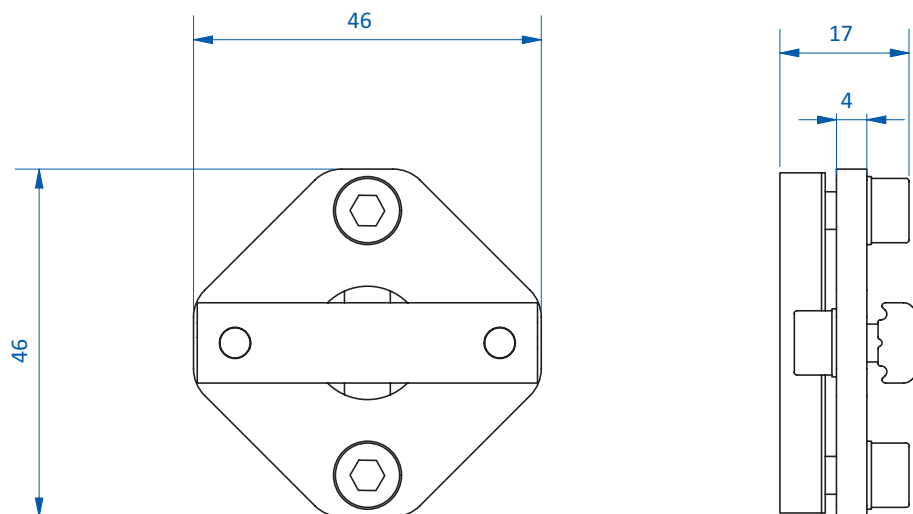



### Profile connectors



#### Product notes

> Elements for 90° connection of two extrusions

#### Technical data

Item no.	Alignment extrusion 1	Profile 1 Height x Width [mm]	Profile 2 Slot nut	Weight [g]
<b>GR01.030</b>	flat	10x20	SLine / MLine / JLine (Universal)	43
<b>GR01.031</b>	flat	10x40	SLine / MLine / JLine (Universal)	58
<b>GR01.040</b>	upright	20x10	SLine / MLine / JLine (Universal)	50
<b>GR01.041</b>	square	20x20	SLine / MLine / JLine (Universal)	55
<b>GR01.042</b>	upright	40x20	SLine / MLine / JLine (Universal)	83
<b>GR01.032</b>	flat	20x40	SLine / MLine / JLine (Universal)	72
<b>GR01.140</b>	square	25x25	MLine / JLine	47
<b>GR01.141</b>	upright	50x25	MLine / JLine	63
<b>GR01.142</b>	flat	25x50	MLine / JLine	66
<b>GR01.198</b>	upright	80x40	MLine / JLine	108
<b>GR01.199</b>	flat	40x80	MLine / JLine	105
<b>GR01.200</b>	square	40x40	MLine / JLine	76

#### Dimensions

A [mm]	B [mm]	C [mm]	D [mm]	E [mm]
10	20	20	40	20
10	40	19.5	60	20
20	10	29.5	30	20
20	20	29.5	40	20
40	20	49.5	40	20
20	40	29.5	60	20
25	25	29.8	45	34
50	25	55	45	59
25	50	33.5	70	38
80	40	90	60	95
40	80	50	100	55
40	40	50	60	54



Application example

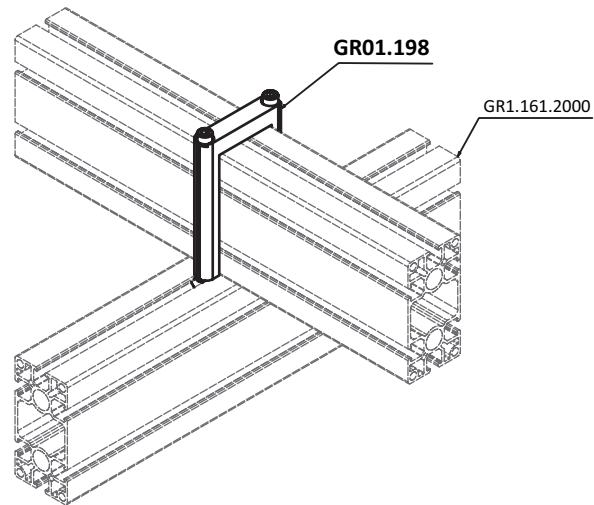

Dimensions

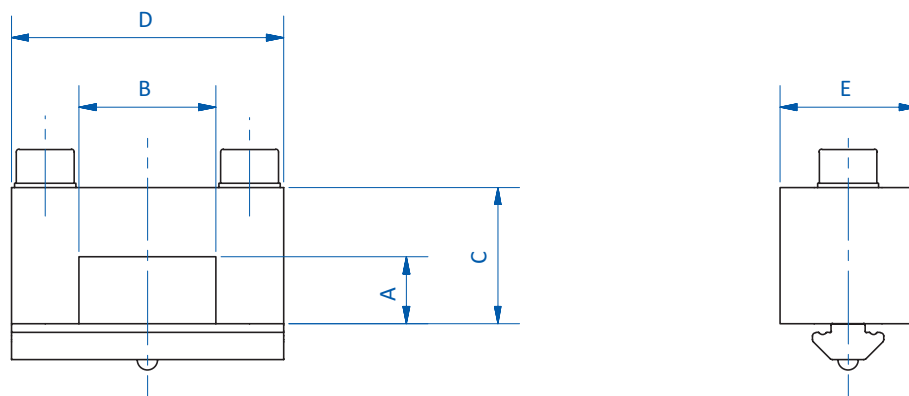



### Angle connectors 90° with cover

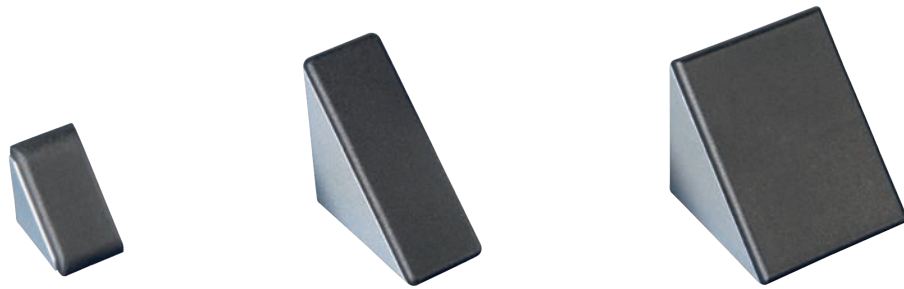

#### Product notes

> Elements for connection of two extrusions

#### Technical data

Item no.	Weight [g]	Suitable for extrusion system
GR01.050	20	SLine / MLine
GR01.051	60	SLine / MLine
GR01.052	150	XLine
GR01.053	270	XLine

#### Dimensions

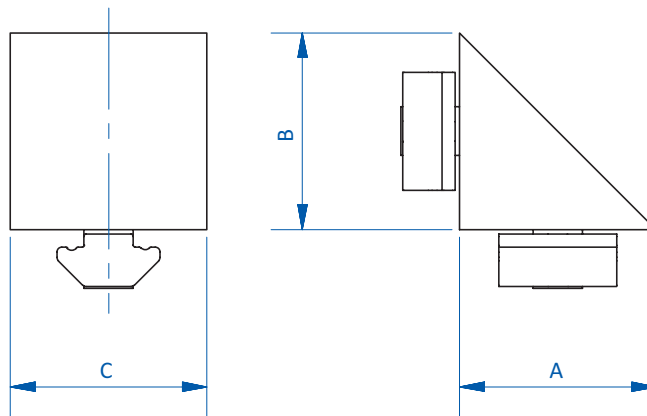

Item no.	A [mm]	B [mm]	C [mm]
GR01.050	20	20	20
GR01.051	41.5	41.5	20
GR01.052	40	40	40
GR01.053	77.5	77.5	38.5



Joining plates 90°

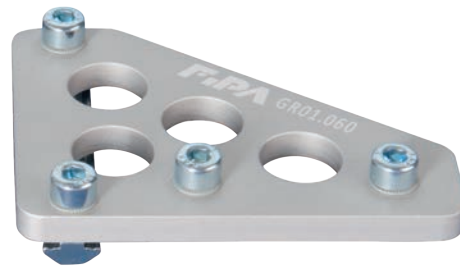

**Product notes**

> Joining plate for 90° connection of two profiles

**Technical data**

Item no.	Suitable for extrusion system	Width [mm]	Weight [g]
GR01.060	SLine / MLine	20	93
GR01.061	SLine / MLine	40	108

**Dimensions**

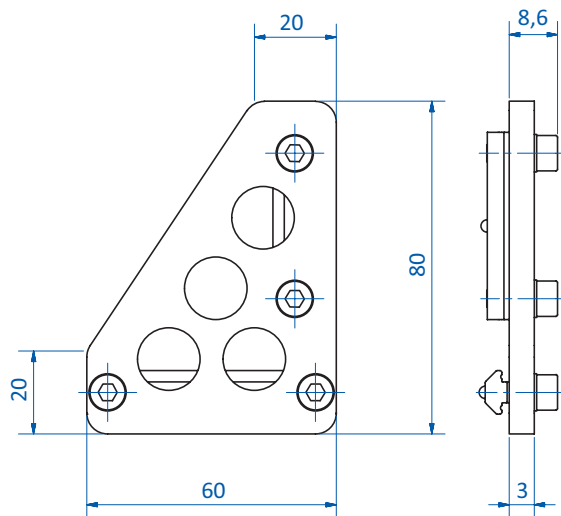

GR01.060

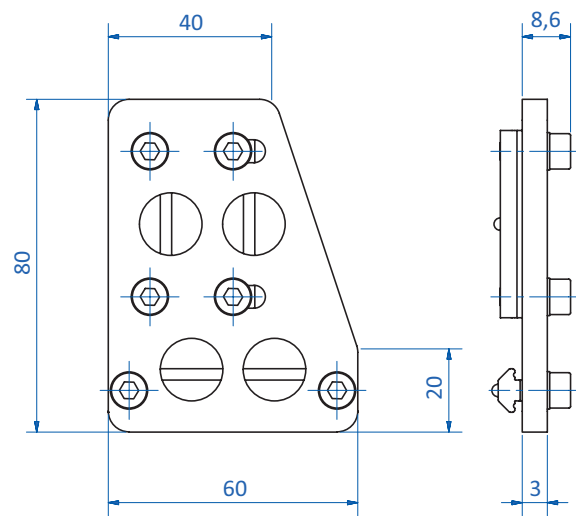

GR01.061



### Corner joint plates 90° to 130°



#### Product notes

> Joining plates for connection of two profiles with a defined angle

#### Technical data

Item no.	Angle [°]	Suitable for extrusion system	Width profile 1 [mm]	Width profile 2 [mm]	Material	Weight [g]
GR01.063	90°, 100°, 110°, 120°, 130°	SLine	20	20	Aluminum	127
GR01.064	90°, 100°, 110°, 120°, 130°	MLine	25	25	Aluminum	131
GR01.217	90°, 110°, 130°	JLine	40	40	Steel	213.3
GR-XL01.063	90°, 110°, 130°	XLine	40	40	Aluminum	284

#### Dimensions

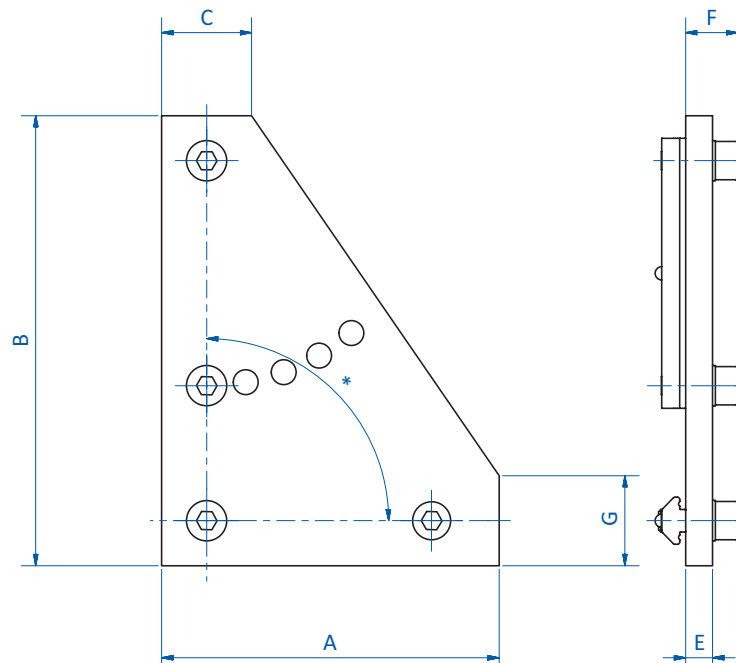

\* = Angle

Item no.	A [mm]	B [mm]	C [mm]	E [mm]	F [mm]	G [mm]
GR01.063	75	100	20	3	8.6	20
GR01.064	75	100	25	3	8.6	25
GR01.217	70	110	40	3	9.7	50
GR-XL01.063	80	120	40	3	11.8	40





## Adjustable profile connectors 0° to 90°



GR01.062

### Product notes

> Joining plates for connection of two profiles with adjustable angle

### Technical data

Item no.	Suitable for extrusion system	Width profile 1 [mm]	Width profile 2 [mm]	Material	Weight [g]
<b>GR01.062</b>	SLine, MLine	20 - 25	20 - 25	Aluminum	77
<b>GR01.216</b>	JLine	40	40	Steel	249.2
<b>GR-XL01.062</b>	XLine	40	40	Steel	225

### Dimensions

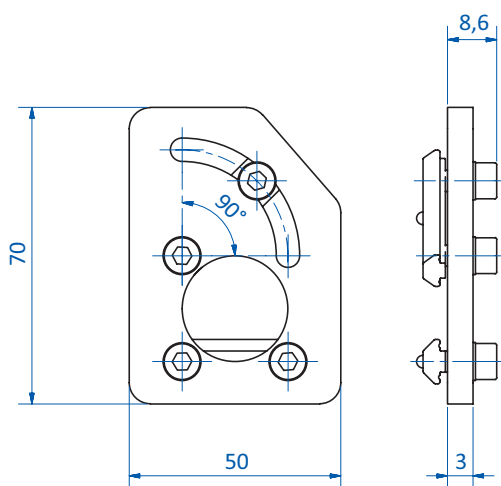

GR01.062

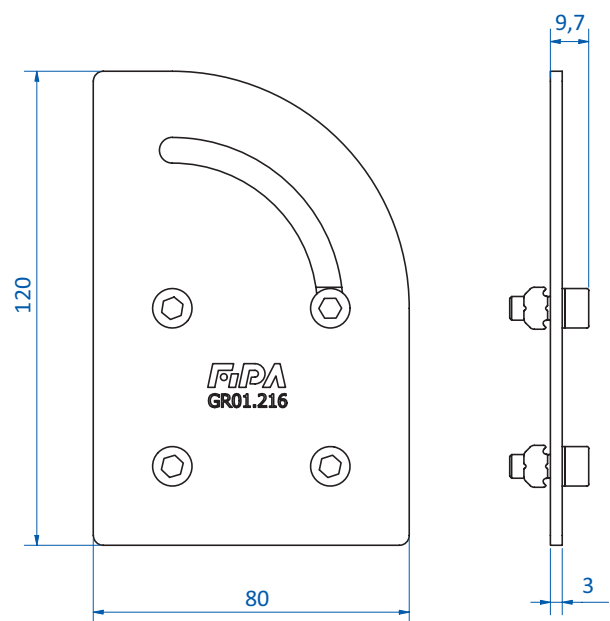

GR01.216

Continued on the next page →



## Dimensions

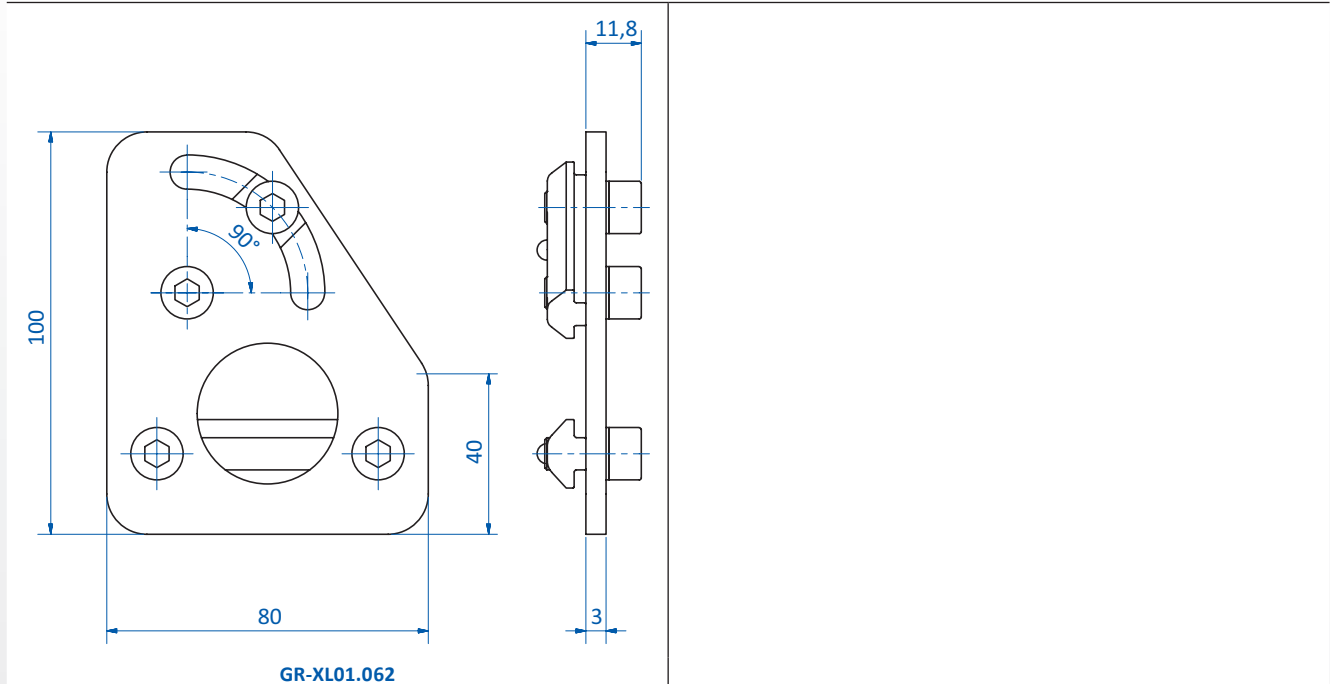



## Profilverbinder – schwenkbar

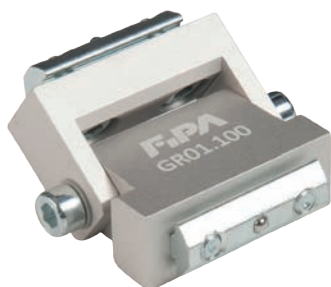

### Produktbeschreibung

- > Winkelvariable Verbindung zwischen zwei parallelen Profilen
- > Zuverlässige Klemmung durch zwei gegenläufige Klemmschrauben
- > Im Lieferumfang enthalten:
  - 2x Nutenstein GR01.093A mit je 2x M5-Bohrung für Längsmontage in der Profilvernut
  - 4x Nutenstein GR01.097A, je 1x M5-Bohrung für Quermontage in der Profilvernut

### Technische Daten

Art.-Nr.	Passend für Profilsystem	Gewicht [g]
GR01.100	SLine / MLine	78

### Abmessungen

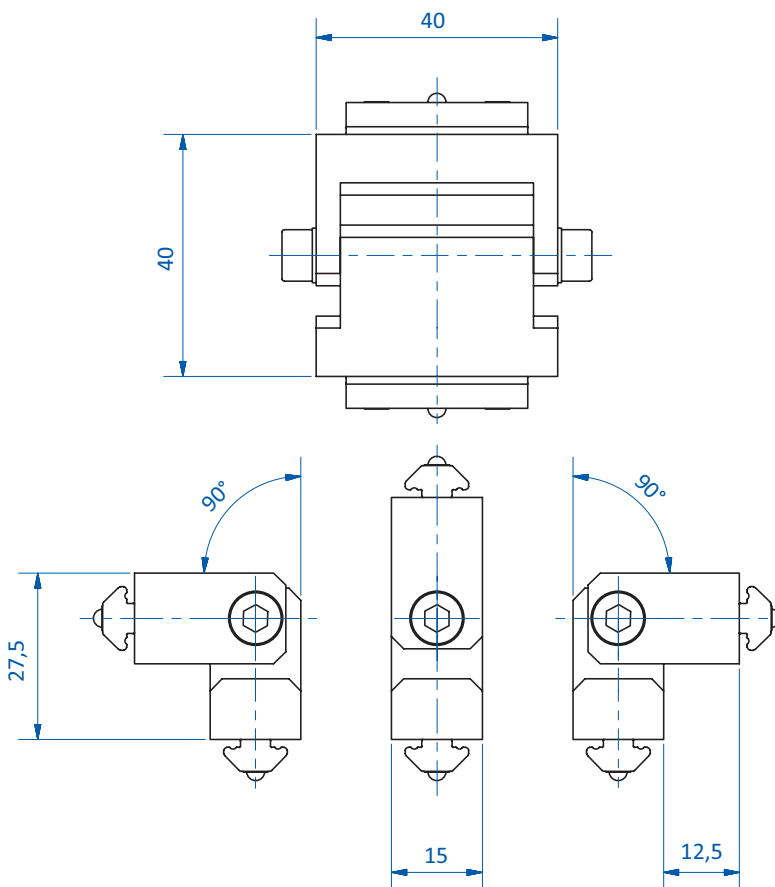



### Profile end connectors 90°



#### Product notes

- > Rigid 90° connection between two extrusions
- > No thread cutting required

#### Technical data

Item no.	Suitable for extrusion system	Weight [g]
<b>GR01.120</b>	SLine / MLine	92
<b>GR01.121</b>	SLine / MLine	90
<b>GR01.122</b>	SLine / MLine	96
<b>GR01.123</b>	SLine / MLine	100
<b>GR-XL01.025</b>	XLine	406
<b>GR-XL01.026</b>	XLine	396

#### Dimensions

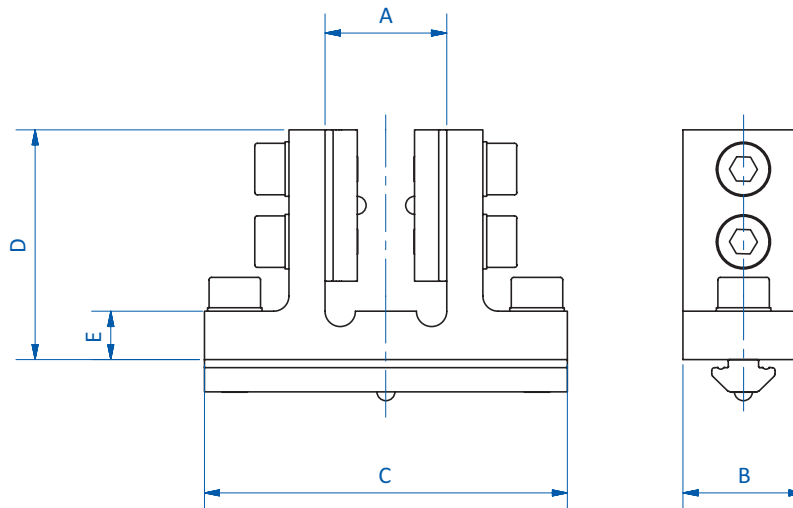

Item no.	A [mm]	B [mm]	C [mm]	D [mm]	E [mm]
<b>GR01.120</b>	20	20	60	38	8
<b>GR01.121</b>	40	20	80	38	8
<b>GR01.122</b>	25	25	60	37	7
<b>GR01.123</b>	50	25	90	37	7
<b>GR-XL01.025</b>	40	40	110	47	12
<b>GR-XL01.026</b>	80	40	150	47	12



### Flat connectors – straight



#### Product notes

> For rigid end-to-end connection of two profiles

#### Technical data

Item no.	Suitable for extrusion system	Weight [g]
GR01.054	SLine / MLine	16
GR01.055	SLine / MLine	50
GR01.056	SLine / MLine	64
GR-XL01.028	XLine	260

#### Dimensions

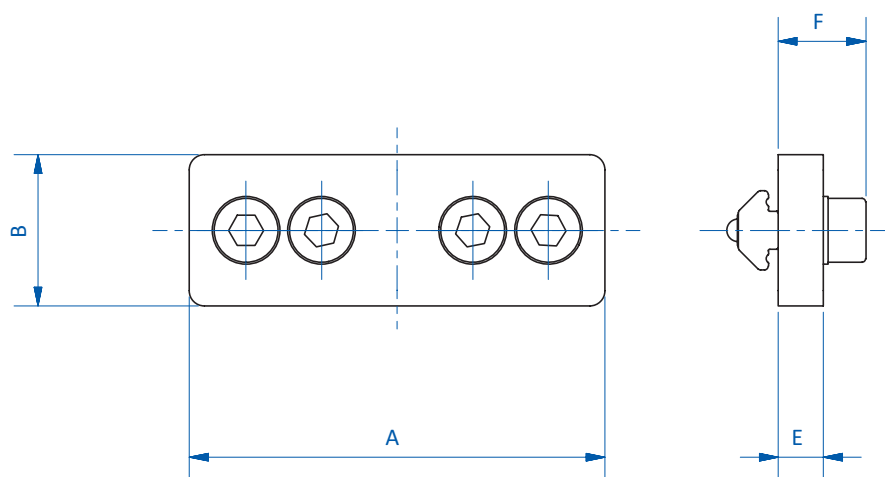

Item no.	A [mm]	B [mm]	E [mm]	F [mm]
GR01.054	55	20	3	9
GR01.055	75	20	3	9
GR01.056	100	20	3	9
GR-XL01.028	160	40	3	12



### Flat connectors – L-form

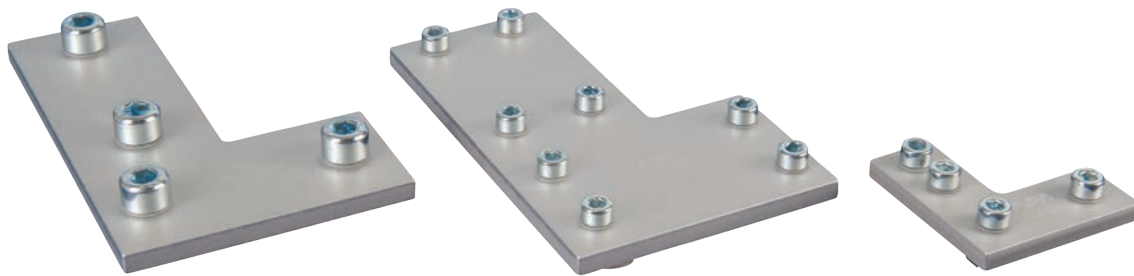

#### Product notes

> For rigid connection of two profiles at 90°

#### Technical data

Item no.	Suitable for extrusion system	Width profile 1 [mm]	Width profile 2 [mm]	Material	Weight [g]
GR01.046	SLine, MLine	20 - 25	20 - 25	Aluminum	66
GR01.047	SLine, MLine	20 - 25	20 - 25	Aluminum	53
GR01.048	MLine	50	50	Aluminum	213
GR01.214	JLine	40	40	Steel	199
GR-XL01.029	XLine	40	40	Aluminum	260

#### Dimensions

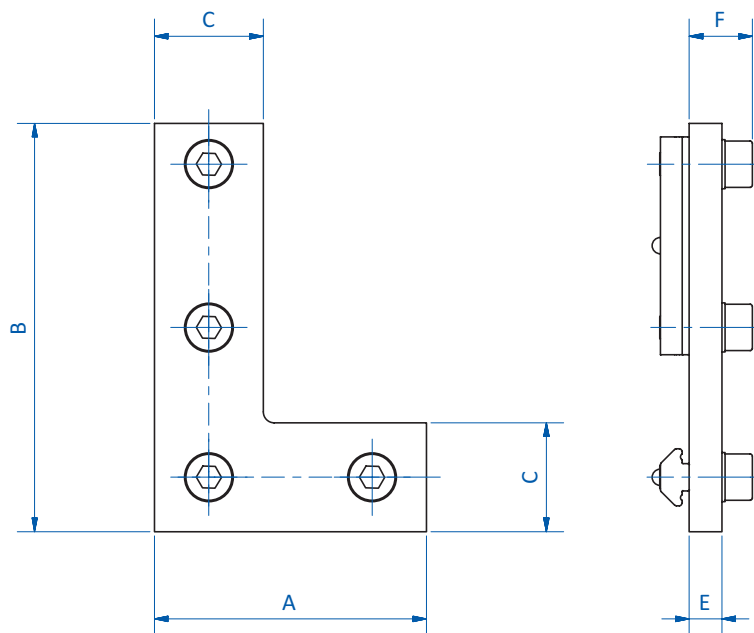

Item no.	A [mm]	B [mm]	C [mm]	E [mm]	F [mm]
GR01.046	50	75	20	3	9
GR01.047	50	50	20	3	9
GR01.048	70	120	50	3	9
GR01.214	75	115	40	3	9.7
GR-XL01.029	80	120	40	3	12



### Flat connectors – T-form

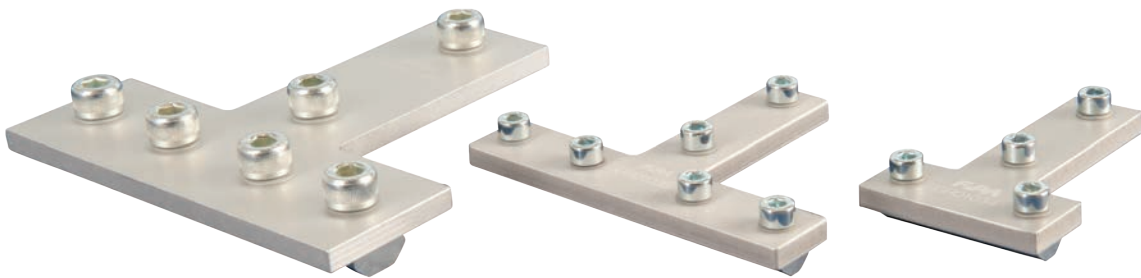

#### Product notes

> For rigid perpendicular connection of two profiles

#### Technical data

Item no.	Suitable for extrusion system	Width profile 1 [mm]	Width profile 2 [mm]	Material	Weight [g]
GR01.034	SLine, MLine	20 - 25	20 - 25	Aluminum	68
GR01.035	SLine, MLine	20 - 25	20 - 25	Aluminum	95
GR01.036	SLine	40	40	Aluminum	123
GR01.037	MLine	50	50	Aluminum	268
GR01.215	JLine	40	40	Steel	265
GR-XL01.035	XLine	40	40	Aluminum	318

#### Dimensions

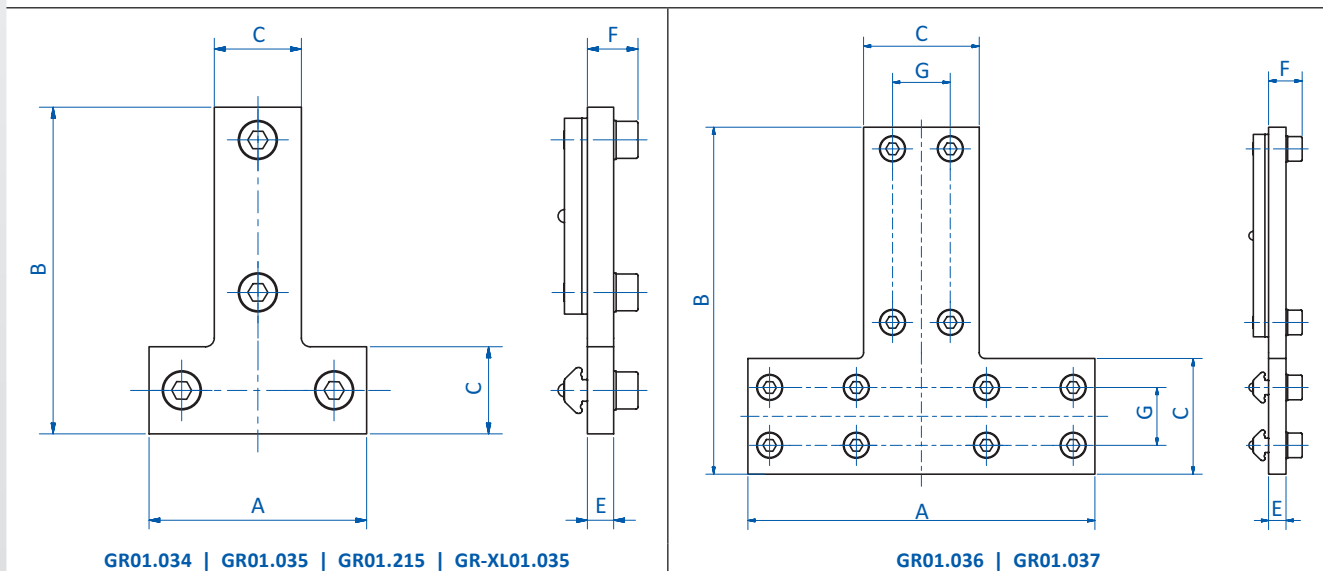

Item no.	A [mm]	B [mm]	C [mm]	E [mm]	F [mm]	G [mm]
GR01.034	50	75	20	3	9	--
GR01.035	100	75	20	3	9	--
GR01.036	120	120	40	3	9	20
GR01.037	120	130	50	3	9	25
GR01.215	120	120	40	3	9.7	--
GR-XL01.035	120	120	40	3	12	--



### Flat connectors 45°



#### Product notes

> For rigid 45° connection of two profiles

#### Technical data

Item no.	Angle [°]	Suitable for extrusion system	Width profile 1 [mm]	Width profile 2 [mm]	Material	Weight [g]
GR01.065	45	SLine	20	20	Aluminum	74
GR01.066	45	MLine	25	25	Aluminum	79
GR01.067	45	JLine	40	40	Steel	173.2

#### Dimensions

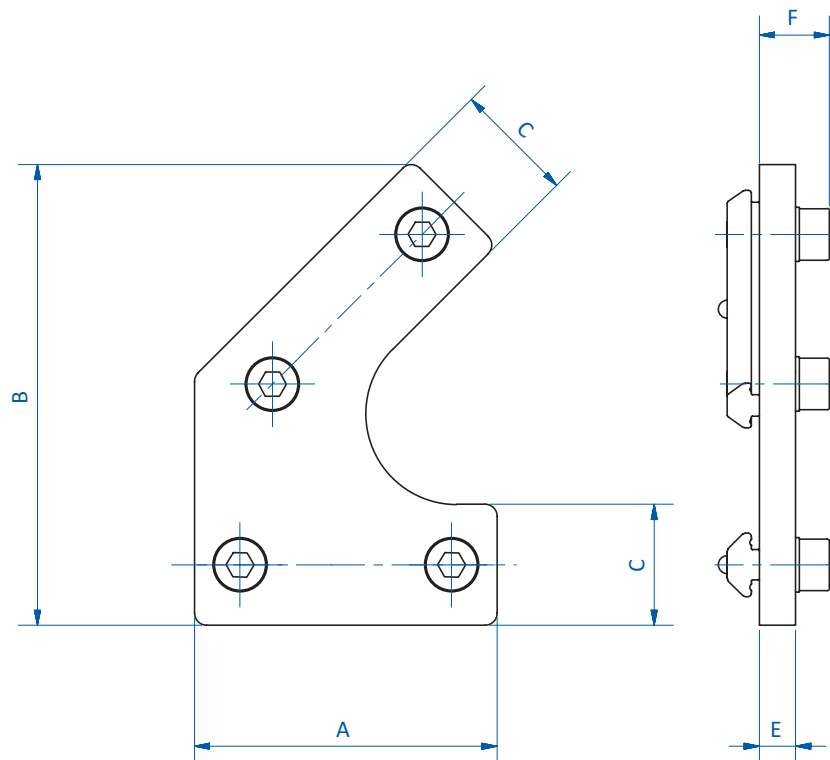

Item no.	A [mm]	B [mm]	C [mm]	E [mm]	F [mm]
GR01.065	50	76	20	3	9
GR01.066	50	76	25	3	9
GR01.067	60	114.9	40	3	9.7





## Profile – Tube – Adapter



### Product notes

> For the transition from profile systems to a tubular system

### Technical data

Item no.	Suitable for extrusion system	Weight [g]
GR01.110	SLine / MLine	28
GR01.111	SLine / MLine	41
GR01.112	SLine / MLine	48

### Dimensions

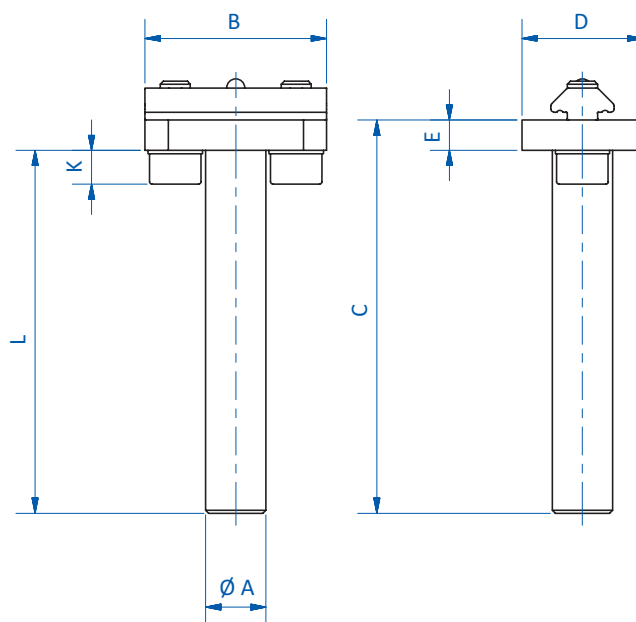

Item no.	Ø A [mm]	B [mm]	C [mm]	D [mm]	E [mm]	K [mm]	L [mm]
GR01.110	10	30	65	20	5	5.6	60
GR01.111	14	35	85	20	5	5.6	80
GR01.112	20	42	105	20	5	5.6	100



### Short angle clamps

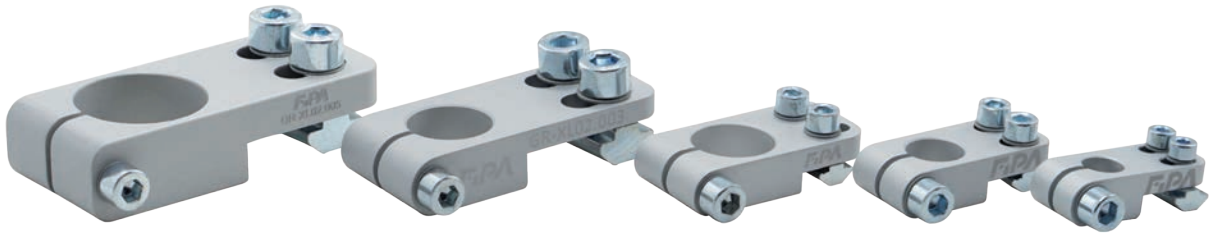

#### Product notes

- > For 90° mounting of gripper components
- > Slotted holes allow for use with profiles from 20 mm to 30 mm in size

#### Technical data

Item no.	Suitable for extrusion system	Weight [g]
GR02.001A	SLine / MLine	26
GR02.003A	SLine / MLine	52
GR02.004	SLine / MLine	41
GR02.005	SLine / MLine	73
GR-XL02.003	XLine	114
GR-XL02.005	XLine	122

#### Dimensions

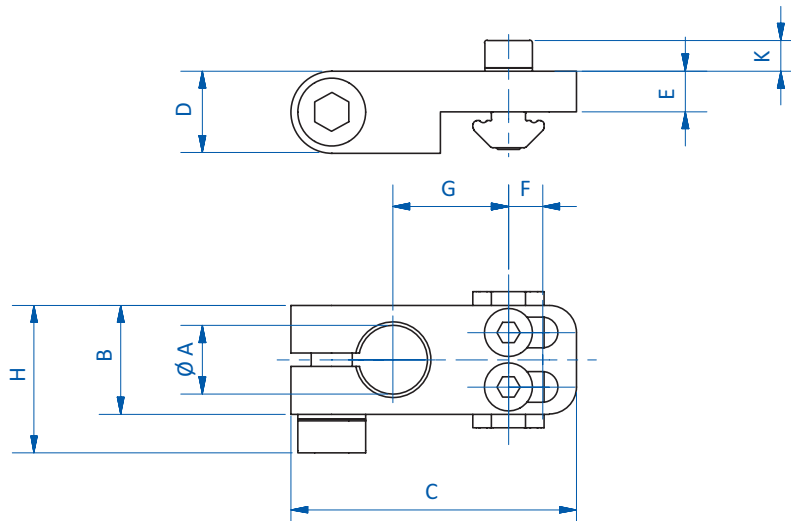

Item no.	Ø A [mm]	B [mm]	C [mm]	D [mm]	E [mm]	F [mm]	G [mm]	H [mm]	K [mm]
GR02.001A	10	16	42	12	6	5	17	22.7	4.5
GR02.003A	20	25	52	12	6.5	5	22	31.7	5.6
GR02.004	14	20	46	12	6.5	5	19	26.7	5.6
GR02.005	30	35	62	20	10	5	27	41.7	5.6
GR-XL02.003	20	30	73	15	6	10	32	36.7	8.8
GR-XL02.005	30	35	82	20	10	10	37	41.7	8.8



Long angle clamps

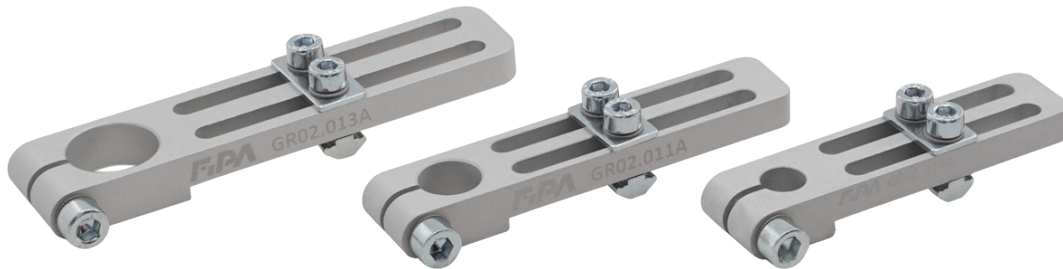

Product notes

- > For 90° mounting of gripper components
- > Allows for adjustment parallel and perpendicular to the profile frame

Technical data			Dimensions								
Item no.	Suitable for extrusion system	Weight [g]	Ø A [mm]	B [mm]	C [mm]	D [mm]	E [mm]	F [mm]	G [mm]	H [mm]	K [mm]
GR02.010A	SLine / MLine	52	10	15	85	12	8	45	15.8	24.2	7.1
GR02.011A	SLine / MLine	58	14	20	98.5	12	8.5	55	17.3	26.7	7.1
GR02.013A	SLine / MLine	85	20	25	114	12	8.5	64.5	20.3	31.7	7.1
GR02.016	SLine / MLine	150	30	35	122	20	10	65	27	41.7	7.1
GR-XL02.013	XLine	140	20	30	150	15	7.5	100	21	36.7	10.3
GR-XL02.016	XLine	213	30	36	162	20	20	100	25.5	44.8	10.3

Dimensions

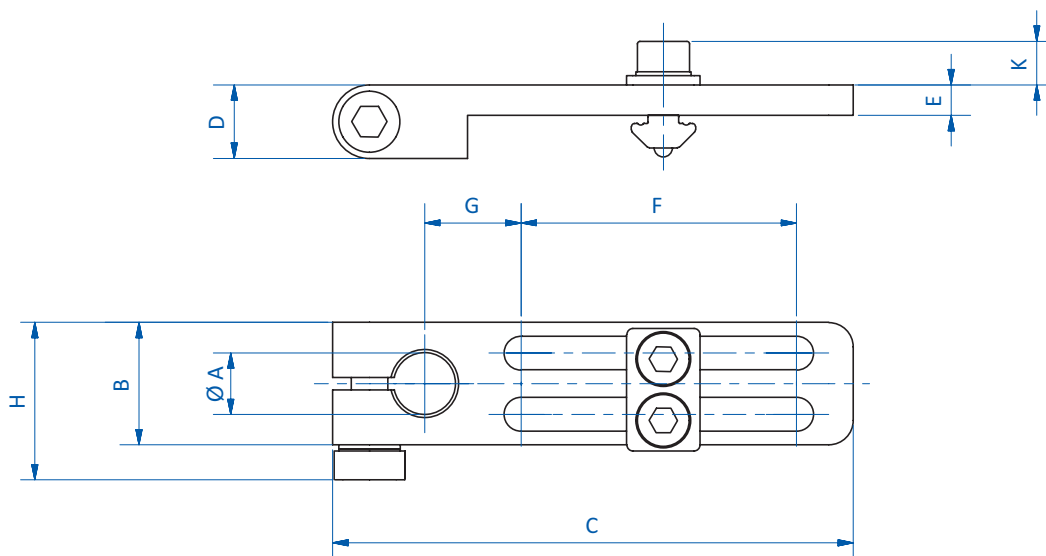



### Long angle clamps – with ball joint

ANGLE CAN BE FREELY ADJUSTED



#### Product notes

- > Ball joint enables variable angular adjustment of gripper components
- > Allows for adjustment parallel and perpendicular to the profile frame

#### Technical data

Item no.	Suitable for extrusion system	Clamping $\varnothing$ [mm]	Angular adjustment [°]	Weight [g]
GR02.035	SLine / MLine	10	38	48
GR02.036	SLine / MLine	14	33	60
GR02.037	SLine / MLine	20	31	145
GR02.038	SLine / MLine	30	28	238
GR02.420	MLine / JLine	10	38	43
GR02.421	MLine / JLine	14	33	67
GR02.422	MLine / JLine	20	31	153
GR-XL02.038	XLine	30	28	260

#### Dimensions

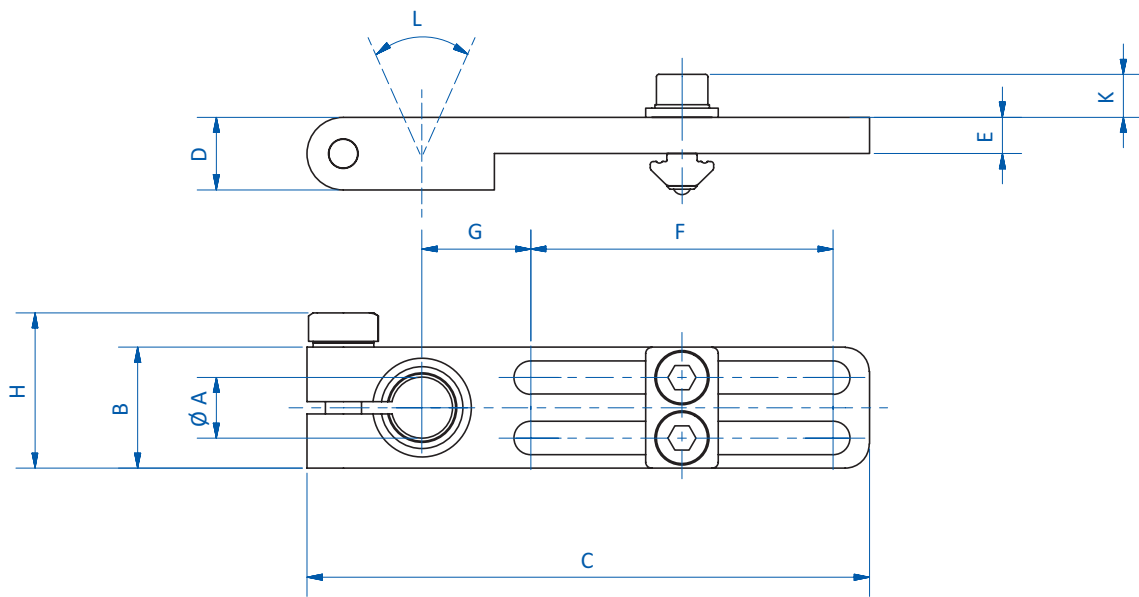

GR02.035 | GR02.036 | GR02.037 | GR02.038 | GR-XL02.038



Dimensions

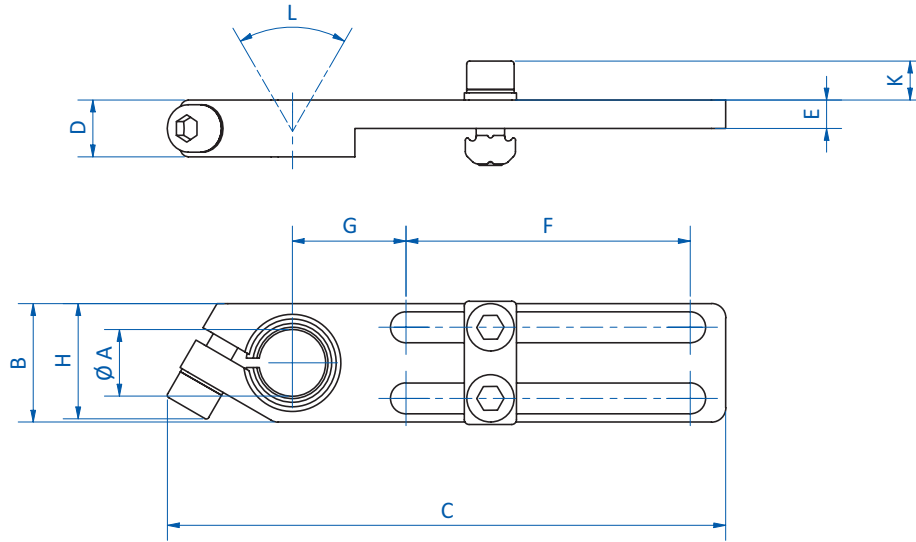

GR02.420 | GR02.421 | GR02.422

Item no.	Ø A [mm]	B [mm]	C [mm]	D [mm]	E [mm]	F [mm]	G [mm]	H [mm]	K [mm]	L [°]
GR02.035	10	20	93	12	6	50	18	26.7	7.1	38
GR02.036	14	25	107	12	6	60	20	31.7	7.1	33
GR02.037	20	35	115	20	10	60	24	41.7	7.1	31
GR02.038	30	45	136	20	17	70	30	46.7	7.1	28
GR02.420	10	20	98	12	6	50	20	20	7.1	38
GR02.421	14	25	118	12	6	60	24	24	8.2	33
GR02.422	20	35	134	20	10	60	29	32	8.2	31
GR-XL02.038	30	45	136	20	20	70	30	46.7	10.3	28



### Long angle clamps – with swivel head



#### Product notes

- > Swivel head allows for angle variable installation of gripper components
- > Allows for adjustment parallel and perpendicular to the profile frame

#### Technical data

Item no.	Suitable for extrusion system	Weight [g]
<b>GR02.026</b>	SLine / MLine / JLine (Universal)	56
<b>GR02.027</b>	SLine / MLine / JLine (Universal)	62
<b>GR02.028</b>	SLine / MLine / JLine (Universal)	90
<b>GR02.029</b>	SLine / MLine / JLine (Universal)	152
<b>GR02.423</b>	MLine / JLine	37.4
<b>GR02.424</b>	MLine / JLine	65.8
<b>GR02.425</b>	MLine / JLine	107.3
<b>GR02.426</b>	MLine / JLine	240.3
<b>GR-XL02.029</b>	XLine	223

#### Application example

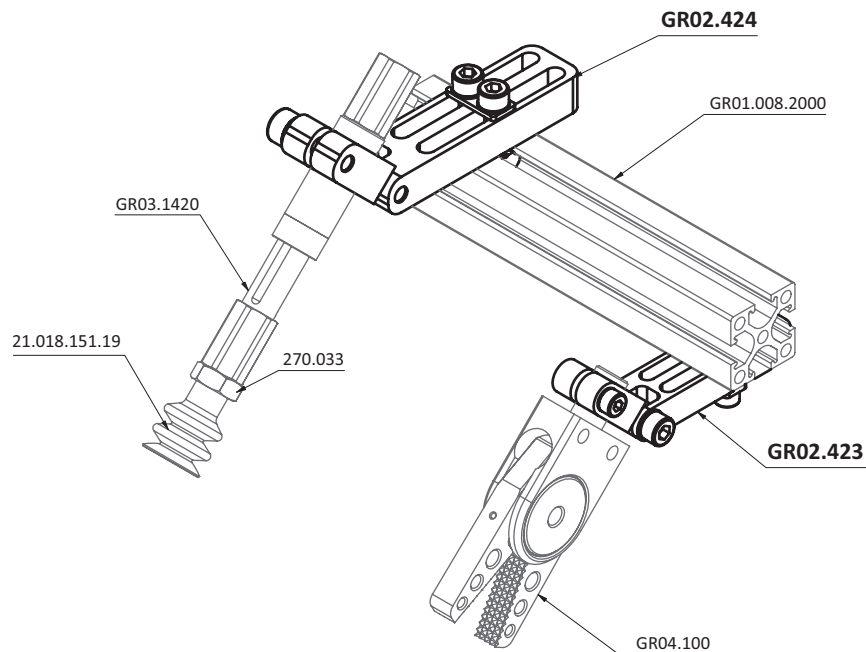



### Dimensions

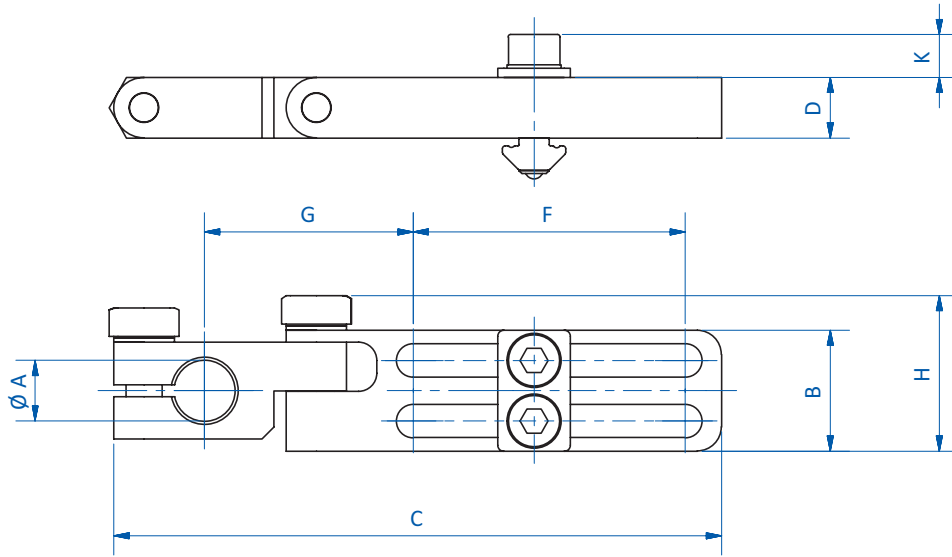

Item no.	Ø A [mm]	B [mm]	C [mm]	D [mm]	F [mm]	G [mm]	H [mm]	K [mm]
GR02.026	10	20	100.5	10	45	34.5	26.7	7.1
GR02.027	14	20	116.5	12	55	37.5	26.7	7.1
GR02.028	20	25	136	15	65	44	31.7	7.1
GR02.029	30	35	183.8	22.5	85	58.8	41.7	7.1
GR02.423	10	16	86	10	40	27	21.6	6
GR02.424	14	20	105.5	12	50	32.5	26.7	7.1
GR02.425	20	25	123.5	15	60	38.5	31.7	7.1
GR02.426	30	35	166	20	82	52	41.7	8.2
GR-XL02.029	30	45	185	20	85	60	46.7	10.3



# Extrusion systems | Clamps for shafts

Long angle clamps – heavy duty with swivel head and ball joint

Long angle clamps – heavy duty with swivel head and ball joint



## Product notes

- > Wide angular adjustment with a single clamp

## Technical data

Item no.	Suitable for extrusion system	Clamping $\varnothing$ [mm]	Weight [g]
<b>GR02.427</b>	MLine / JLine	10	68
<b>GR02.428</b>	MLine / JLine	14	117
<b>GR02.429</b>	MLine / JLine	20	161

## Application example

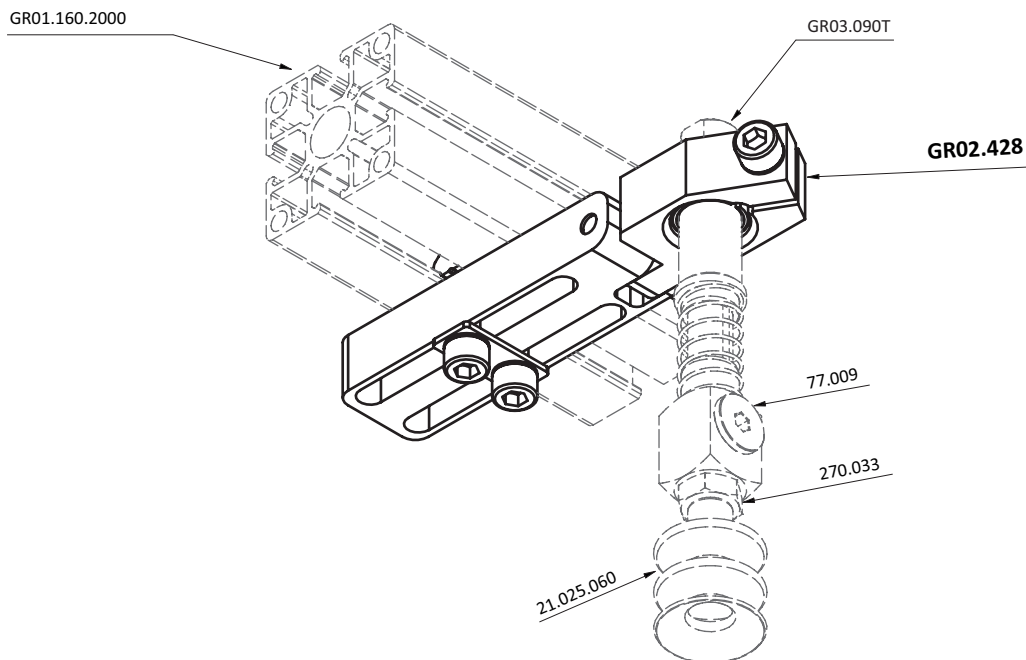





## Dimensions

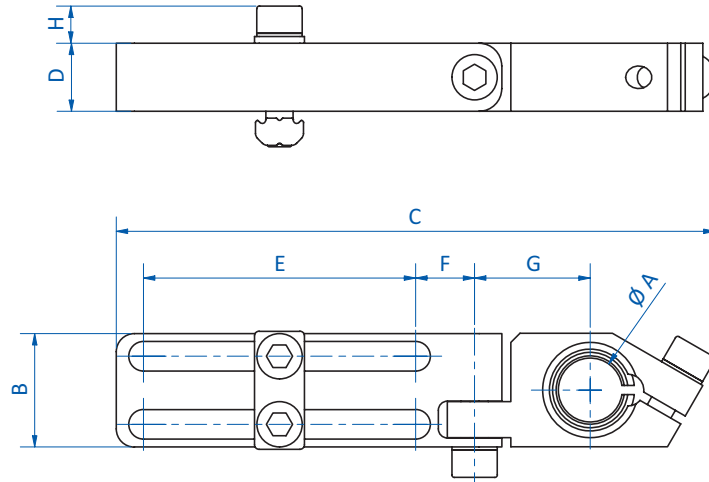

Item no.	$\Delta A$ [mm]	B [mm]	C [mm]	D [mm]	E [mm]	F [mm]	G [mm]	H [mm]
GR02.427	10	20	111	12	50	12	20.5	7.1
GR02.428	14	25	132	15	60	13	25.5	8.2
GR02.429	20	35	172	20	82	19	29.5	8.2



### Angle clamps – customizable

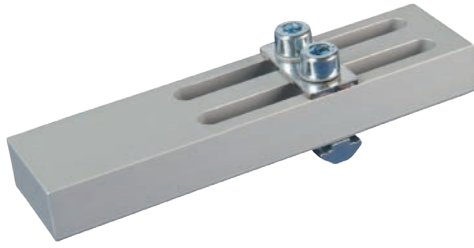

#### Product notes

- > Mounting blank for custom solutions
- > Allows for adjustment parallel and perpendicular to the profile frame

#### Technical data

Item no.	Suitable for extrusion system	Weight [g]
GR02.014	SLine / MLine	47
GR02.015	SLine / MLine	84

#### Dimensions

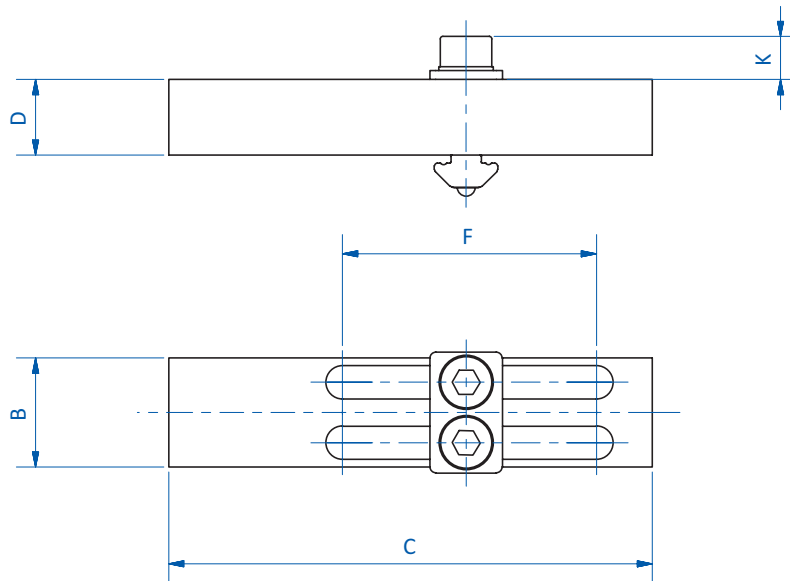

Item no.	B [mm]	C [mm]	D [mm]	F [mm]	K [mm]
GR02.014	18	80	12.5	42	7.1
GR02.015	25	100	12.5	52	7.1



### Angle clamps MLine / JLine

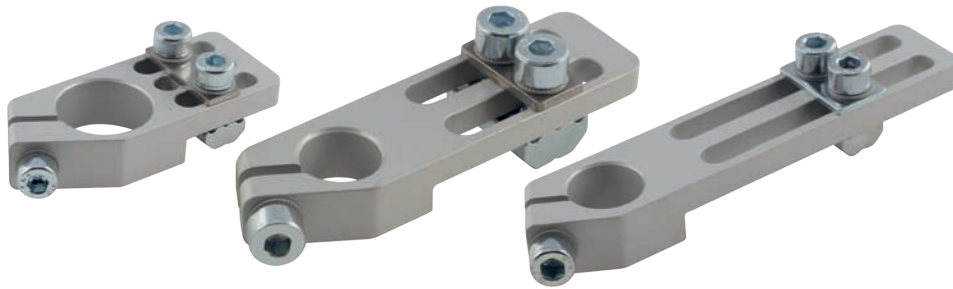

#### Product notes

- > Space-saving design
- > Allows for adjustment parallel and perpendicular to the profile frame

#### Technical data

Item no.	Design	Clamping $\varnothing$ [mm]	Suitable for extrusion system	Weight [g]
GR02.406	Short	10	MLine / JLine	19
GR02.407	Short	14	MLine / JLine	32
GR02.408	Short	20	MLine / JLine	40
GR02.409	Short	30	MLine / JLine	89
GR02.436	Medium	10	MLine / JLine	20
GR02.437	Medium	14	MLine / JLine	36
GR02.438	Medium	20	MLine / JLine	78
GR02.439	Medium	30	MLine / JLine	107
GR02.412	Long	10	MLine / JLine	21
GR02.413	Long	14	MLine / JLine	40
GR02.414	Long	20	MLine / JLine	90
GR02.415	Long	30	MLine / JLine	128

#### Dimensions

$\varnothing A$ [mm]	B [mm]	C [mm]	D [mm]	E [mm]	F [mm]	G [mm]	K [mm]
10	16	49	8	4	7.5	18	6
14	20	56	12	6	9	18.5	7.1
20	25	64	12	6	15	16	7.1
30	35	85	20	10	20	22.5	8.1
10	16	59	8	4	20	16	6
14	20	75	12	6	25	21	7.1
20	30	101	15	7.5	35	31	8.1
30	35	108	20	10	35	30	8.1
10	16	80	8	4	40	16	6
14	20	99	12	6	50	21	7.1
20	30	136	15	7.5	70	31	8.1
30	35	142	20	10	70	30	8.1

#### Dimensions

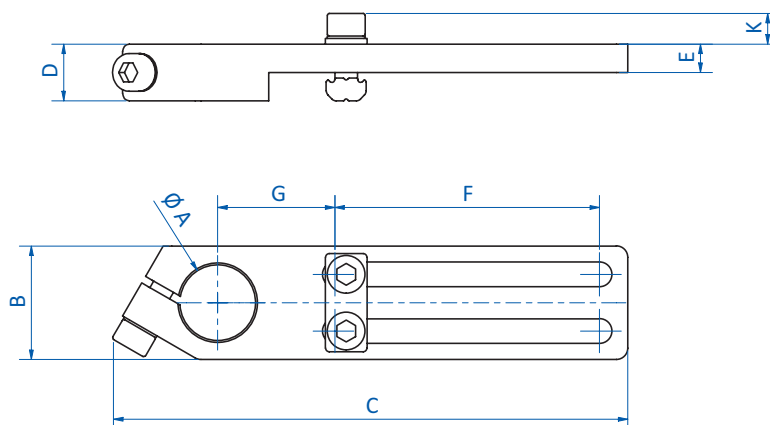



### Long angle clamps MLine / JLine – heavy duty

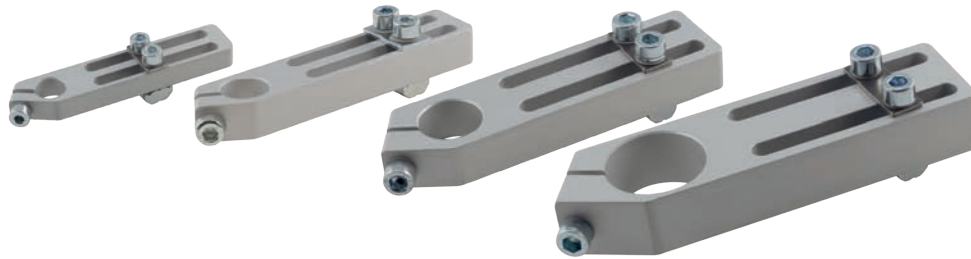

#### Product notes

- > Allows for adjustment parallel and perpendicular to the profile frame
- > Space-saving design
- > For heavy-duty applications

#### Technical data

Item no.	Design	Clamping $\varnothing$ [mm]	Suitable for extrusion system	Weight [g]
GR02.416	Long, heavy duty	10	MLine / JLine	27
GR02.417	Long, heavy duty	14	MLine / JLine	53
GR02.418	Long, heavy duty	20	MLine / JLine	115
GR02.419	Long, heavy duty	30	MLine / JLine	177

#### Dimensions

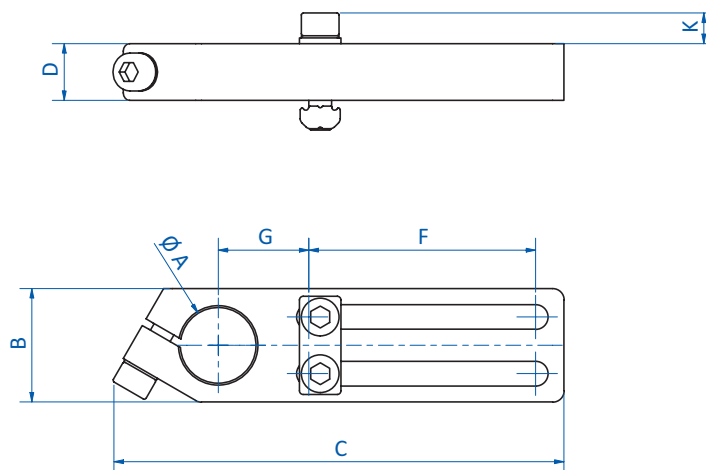

Item no.	$\varnothing A$ [mm]	B [mm]	C [mm]	D [mm]	F [mm]	G [mm]	K [mm]
GR02.416	10	16	79	8	40	16	6
GR02.417	14	20	99	12	50	21	7.1
GR02.418	20	30	119	15	60	24	8.1
GR02.419	30	35	133	20	60	30	8.1



Cross clamps



Product notes

- > Elements for 90° clamping of gripper components
- > Clamp allows transition from profile systems to a tubular system

Technical data

Item no.	Suitable for extrusion system	Weight [g.]
GR02.020	SLine / MLine	32
GR02.022	SLine / MLine	50
GR02.023	SLine / MLine	35
GR02.024	SLine / MLine	97
GR-XL02.022	XLine	103
GR-XL02.024	XLine	172

Dimensions

$\varnothing A$ [mm]	B [mm]	C [mm]	D [mm]	F [mm]	G [mm]	H [mm]
10	18	30	15	20	9	23.6
20	28	40	15	30	14	33.6
14	19.5	35	15	25	9.8	25.1
30	34	60	20	50	17	39.6
20	24.5	45	20	30	12.3	33.3
30	34	68	20	55	17	42.8

Dimensions

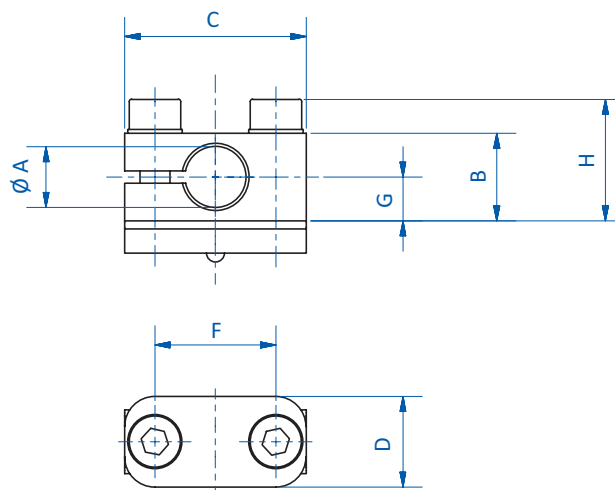



### Heavy-duty cross clamps



#### Product notes

- > Heavy-duty clamps for mounting gripper components
- > Channel nuts locate on perpendicular faces of the profile to minimize deflection of critical components

#### Technical data

Item no.	Clamping $\phi$ [mm]	Suitable for extrusion system	Weight [g]
GR02.006	10	SLine	37
GR02.400	10	MLine	42
GR02.401	14	MLine	43.4
GR02.402	20	MLine	75
GR02.403	20	JLine	99
GR02.404	30	JLine	192

#### Dimensions

$\phi A$ [mm]	B [mm]	C [mm]	D [mm]	E [mm]	F [mm]
10	40	11	20	20	31
10	36	9	19	25	30
14	40	9	22	25	30
20	48	12	29	32	38
20	58	12	30	35	41
45	73	15	45	45	52

#### Dimensions

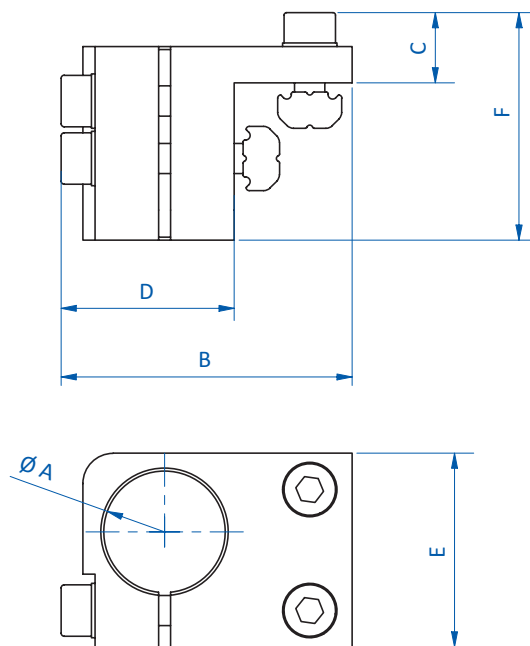



Cross clamps – with ball joint

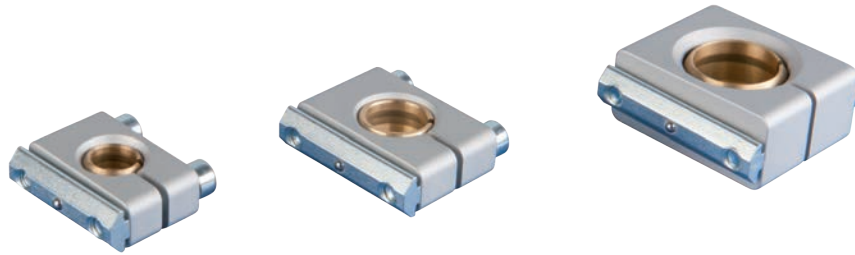

Product notes

- > Elements for clamping of gripper components
- > Ball joint enables variable angular adjustment of gripper components

Technical data

Item no.	Suitable for extrusion system	Angular adjustment [°]	Weight [g]
GR02.020-KG	SLine / MLine	19	38
GR02.022-KG	SLine / MLine	16	98
GR02.023-KG	SLine / MLine	17	49

Dimensions

$\varnothing A$ [mm]	B [mm]	C [mm]	D [mm]	F [mm]	G [mm]	H [mm]	L [°]
10	20	35	12	25	10	25.6	19
20	35	45	20	35	17.5	40.6	16
14	25	40	12	30	12.5	30.6	17

Dimensions

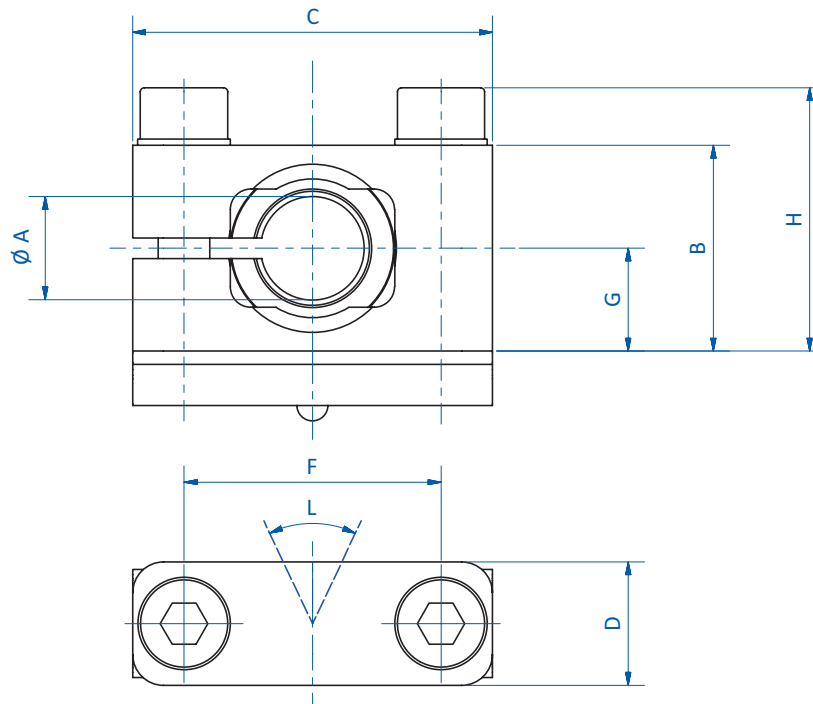



### Threaded mounting brackets

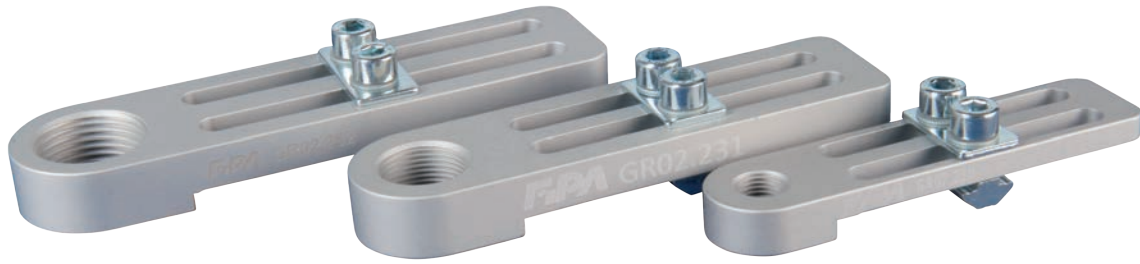

#### Product notes

> Mounting of G1/8, M16 x 1 and M20 x 1.5 spring levers and spring loaded gripper arms to profiles

#### Technical data

Item no.	Suitable for extrusion system	Weight [g]
GR02.230	SLine / MLine	29
GR02.231	SLine / MLine	55
GR02.232	SLine / MLine	63

#### Dimensions

G	A [mm]	B [mm]	C [mm]	D [mm]	E [mm]	F [mm]	K [mm]
G1/8	20	82	17	45	9	5	7.1
M16x1	26	99	21	55	12	8.5	7.1
M20x1.5	28	110	21	65	12	8.5	7.1

#### Dimensions

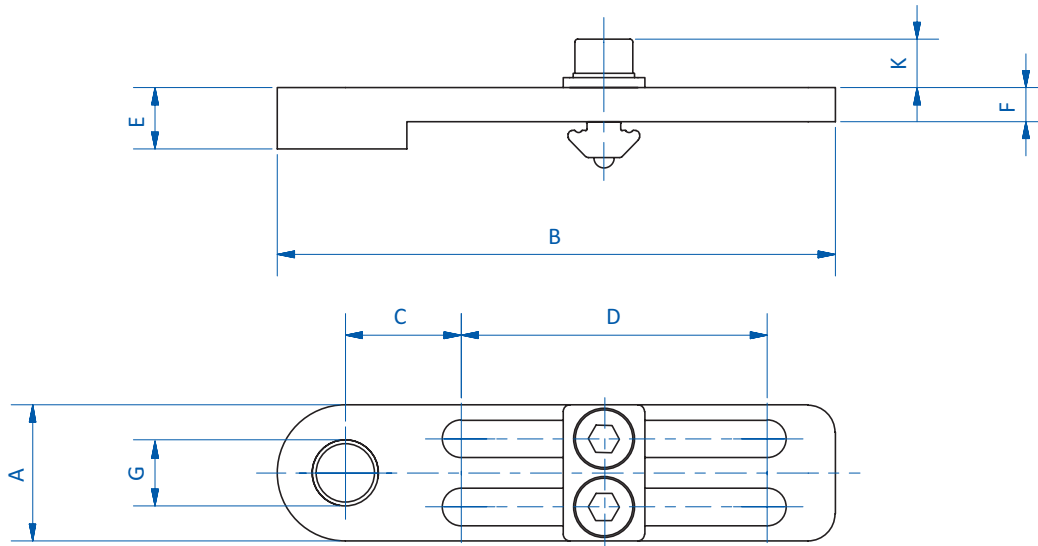





Parallel clamps



Product notes

> Parallel connection of two clamping shafts

Technical data

Item no.	Clamping $\varnothing$ [mm]	Weight [g]
GR02.220	10	30
GR02.221	14	35
GR02.222	20	60
GR02.224	30	90.5

Dimensions

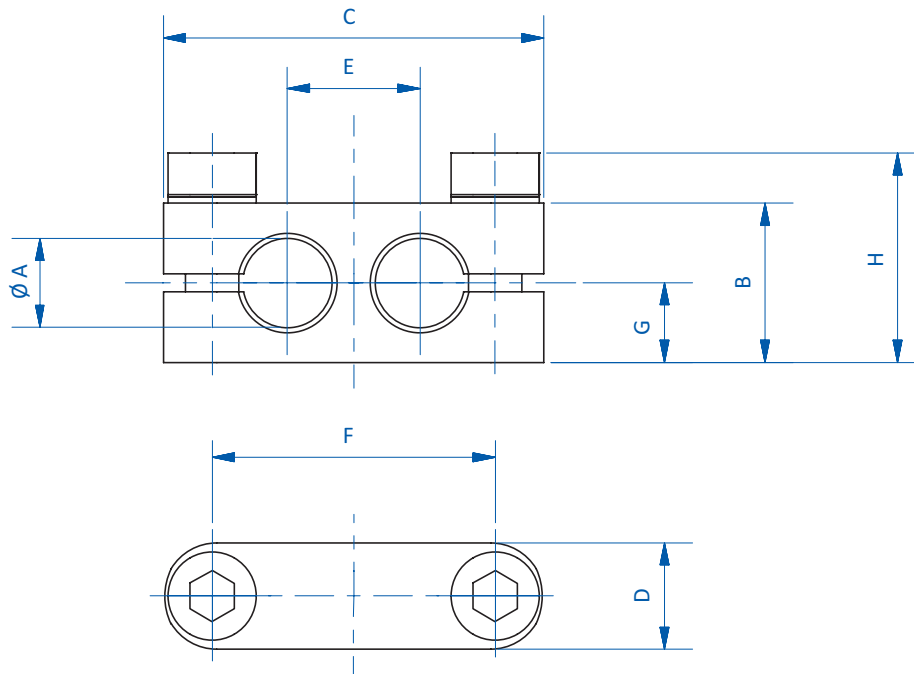

Item no.	$\varnothing A$ [mm]	B [mm]	C [mm]	D [mm]	F [mm]	E [mm]	G [mm]	H [mm]
GR02.220	10	18	43	12	32	15	9	22.7
GR02.221	14	20	52	12	41	20	10	26.7
GR02.222	20	25	64	14	53	26	12.5	31.7
GR02.224	30	35	88	20	77	38	17.5	41.7



### Cross clamps 90°



#### Product notes

- > Perpendicular clamping of tubular components
- > Versatile 90° connection of two clamping shafts of the same size

#### Technical data

Item no.	Weight [g]
GR02.210	28
GR02.211	33
GR02.212	58

#### Dimensions

$\varnothing A$ [mm]	B [mm]	C [mm]	G [mm]	H [mm]
10	16	40	12	22.7
14	18	48	16	24.7
20	24	60	22	30.7

#### Dimensions

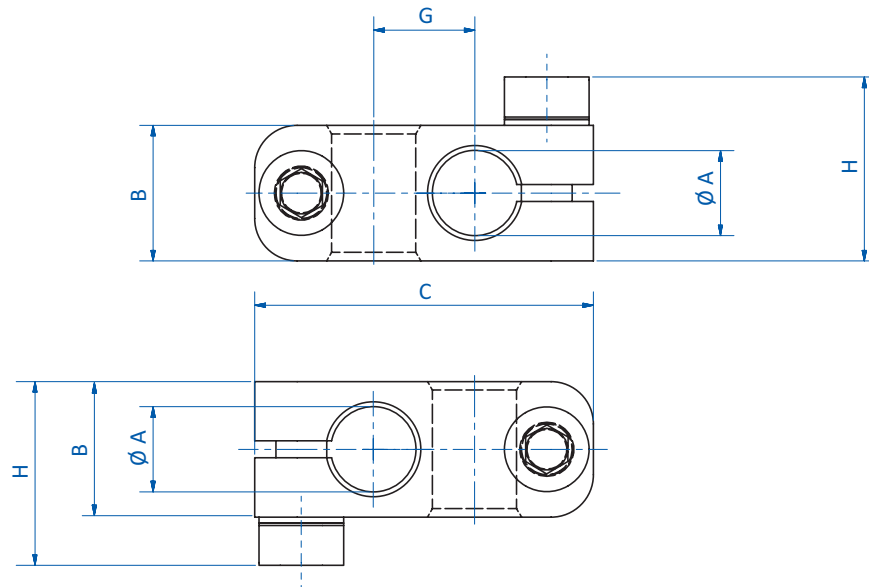



Locator pins



Product notes

- > Alignment of EOAT and locating of parts
- > Locator pins made of POM

Technical data

Item no.	Weight [g]	Suitable extension tube
GR06.001	4	GR06.018 GR06.019 GR06.020
GR06.002A	22	GR06.014 GR06.021A GR06.015
GR06.003	63	GR06.016 GR06.022 GR06.017
GR06.004	105	GR06.026 GR06.027 GR06.028

Dimensions

G	Ø A [mm]	B [mm]	H [mm]
M8x1	10	40	50
M12x1	14	85	100
M17x1	20	135	150
M27x1	30	100	115

Dimensions

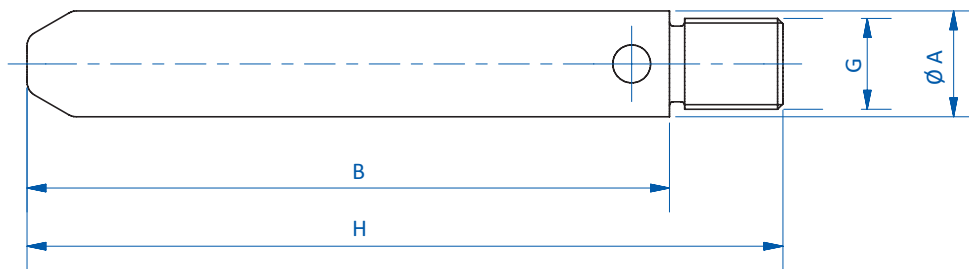



### Angle connectors for vacuum cups

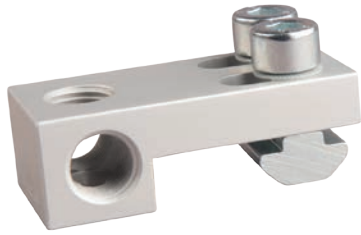

#### Product notes

- > Three vacuum ports
- > Slotted holes allow for use with profiles from 20 mm to 30 mm (GR02.030A ud GR02.031A) and 40 mm to 60 mm (GR-XL02.033) in size

#### Technical data

Item no.	Suitable for extrusion system	Weight [g]
<b>GR02.030A</b>	SLine / MLine	18
<b>GR02.031A</b>	SLine / MLine	37
<b>GR-XL02.033</b>	XLine	94

#### Dimensions

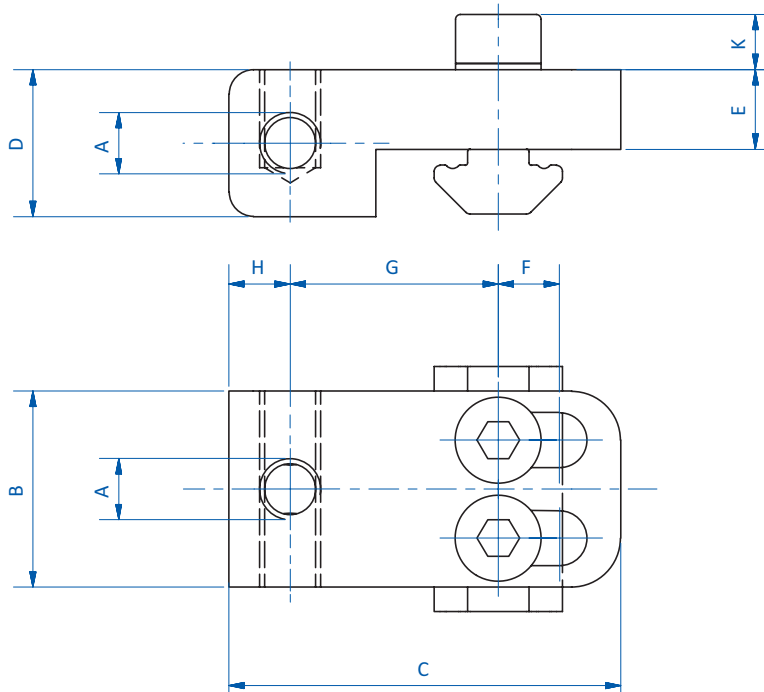

Item no.	A	B [mm]	C [mm]	D [mm]	E [mm]	F [mm]	G [mm]	H [mm]	K [mm]
<b>GR02.030A</b>	M5	16	32	12	6.5	5	17	5	4.5
<b>GR02.031A</b>	G1/8	27	38	15	6.5	5	20	8	5.6
<b>GR-XL02.033</b>	G1/4	30	60	20	10	10	29	11	8.8



### Long angle connectors for vacuum cups

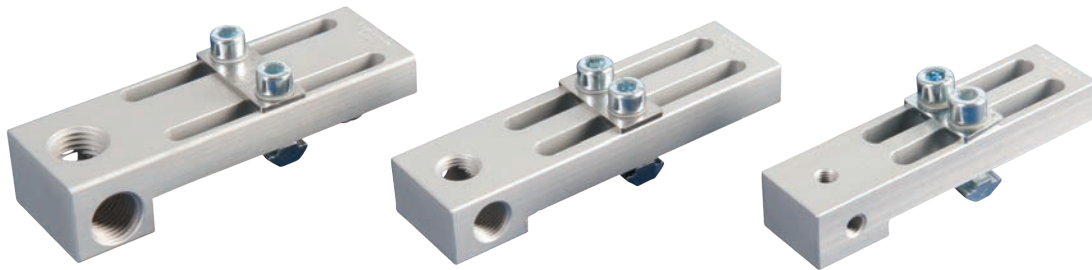

#### Product notes

- > Three vacuum ports
- > Allows for adjustment parallel and perpendicular to the profile frame

#### Technical data

Item no.	Suitable for extrusion system	Weight [g]
GR02.040	SLine / MLine	44
GR02.041	SLine / MLine	58
GR02.043	SLine / MLine	86

#### Dimensions

A	B [mm]	C [mm]	D [mm]	E [mm]	F [mm]	G [mm]	H [mm]	K [mm]
M5	18	74	12	5	42	17	5	7.1
G1/8	27	90	15	8.5	52	20.8	8	7.1
G1/4	36	94	18	8.5	52	22	10	7.1

#### Dimensions

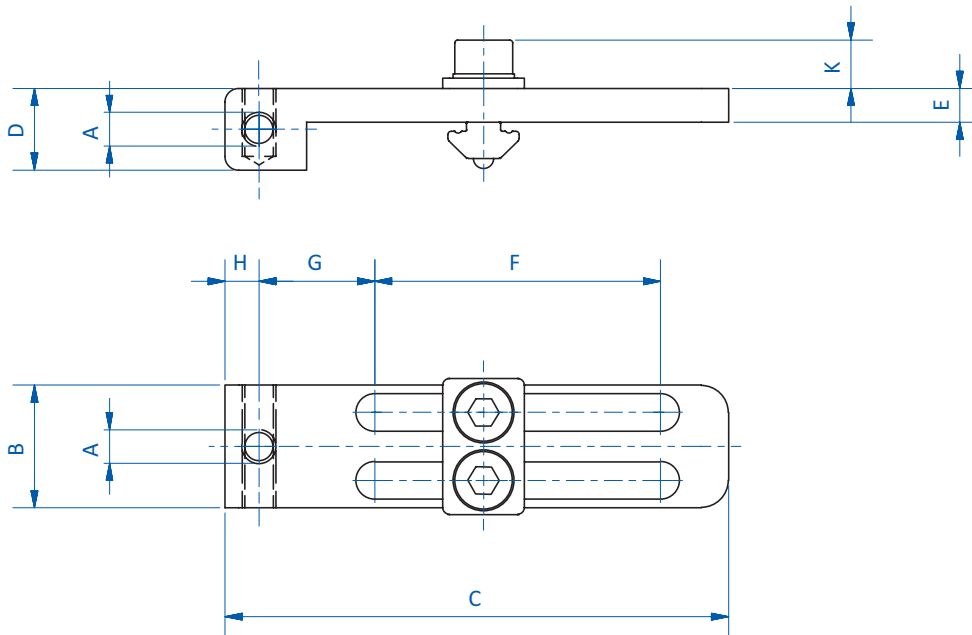



### Vacuum cup connectors – perpendicular



#### Product notes

- > Compact mounting of vacuum cups to profiles

#### Technical data

Item no.	Suitable for extrusion system	Weight [g]
GR02.050	SLine / MLine	24
GR02.051	SLine / MLine	36
GR02.053	SLine / MLine	49

#### Dimensions

A	H	B [mm]	C [mm]	D [mm]	E [mm]	G [mm]
M5	M5	15	30	15	6.5	10
G1/8	G1/8	15	40	20	6.5	20
G1/4	G1/4	20	40	25	6.5	20

#### Dimensions

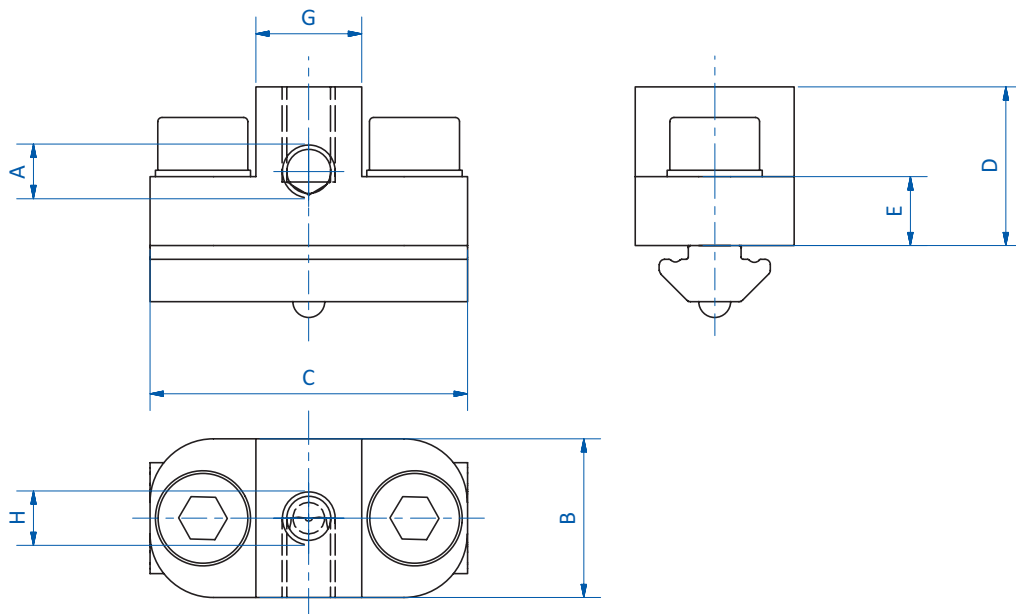



### Vacuum cup connectors – rotatable 360°

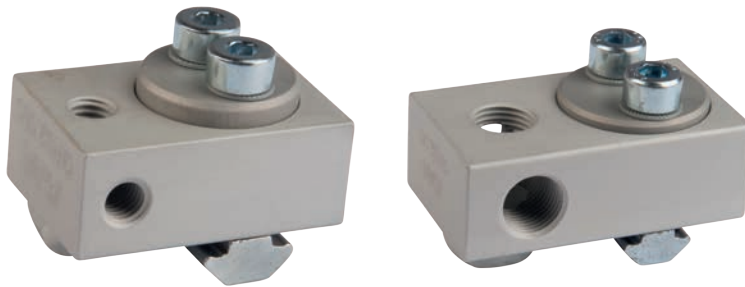

#### Product notes

- > 360° adjustability
- > Three vacuum ports

#### Technical data

Item no.	Suitable for extrusion system	Weight [g]
GR02.060	SLine / MLine	24
GR02.061	SLine / MLine	48

#### Dimensions

	B [mm]	C [mm]	D [mm]	F [mm]	H [mm]
M5	12	30	20	14	19
G1/8	15	43	27	20	22.1

#### Dimensions

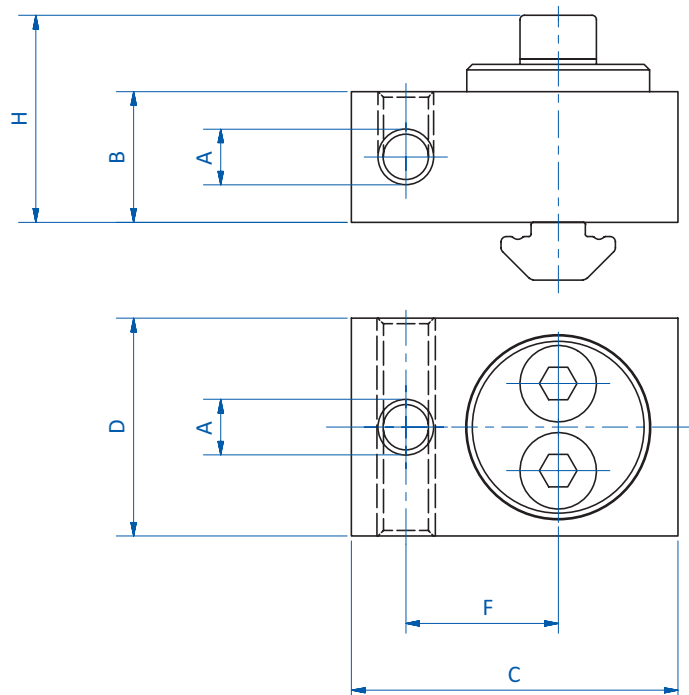



### Vacuum cup connectors – rotatable



#### Product notes

- > For mounting vacuum cups to profiles
- > Swivel head enables adjustment of the angle

#### Technical data

Item no.	Suitable for extrusion system	Connection	Weight [g]
GR07.020	SLine / MLine	G1/4	79

#### Dimensions

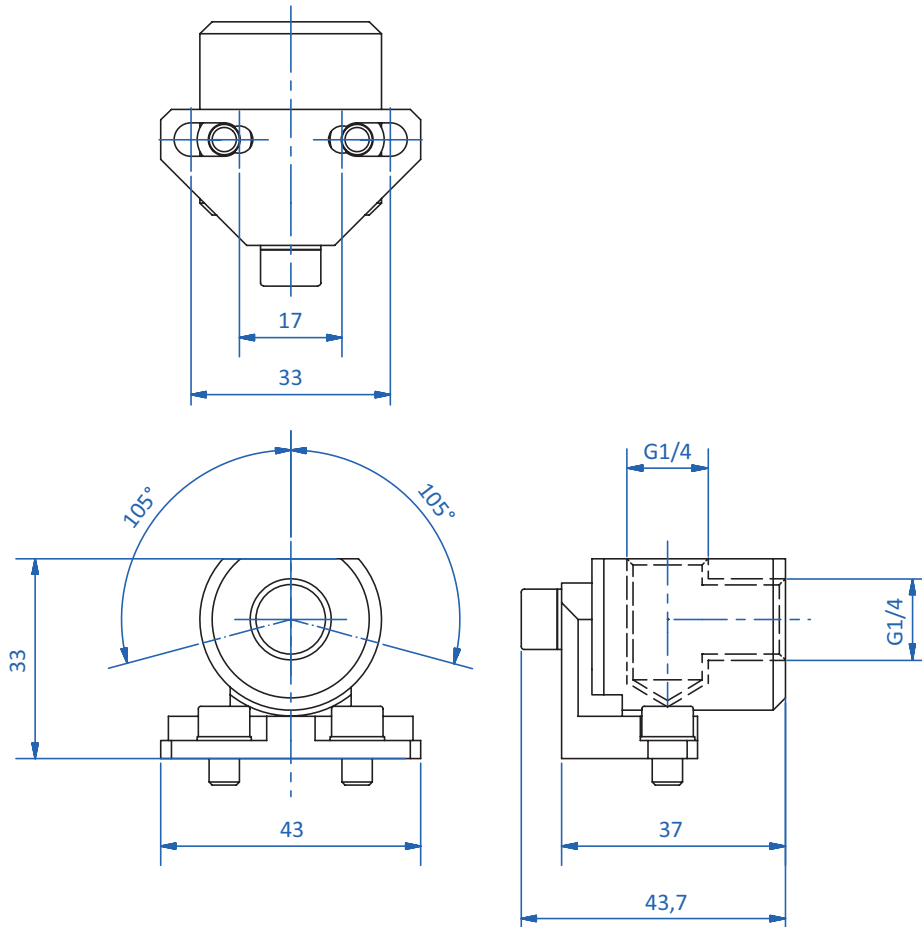





### Air and vacuum manifolds



#### Product notes

> Distribution of air or vacuum in gripper systems

#### Technical data

Item no.	Suitable for extrusion system	Number of inputs	Number of outputs per input	Total outputs	Shorthand of connections	Connection	Weight [g]	Suitable sealing plugs
GR05.001	SLine / MLine	1	4	4	5	G1/8	31	77.009
GR05.011	JLine	1	4	4	5	G1/8	39	77.009
GR05.002	SLine / MLine	2	4	8	10	G1/8	49	77.009
GR05.012	JLine	2	4	8	10	G1/8	57	77.009
GR05.003	SLine / MLine	2	6	12	14	G1/8 (outputs), G1/4 (inputs)	155	77.009 77.008
GR05.004	SLine / MLine	1	8	8	9	G1/8	50	77.009
GR05.014	JLine	1	8	8	9	G1/8	58	77.009

#### Application example

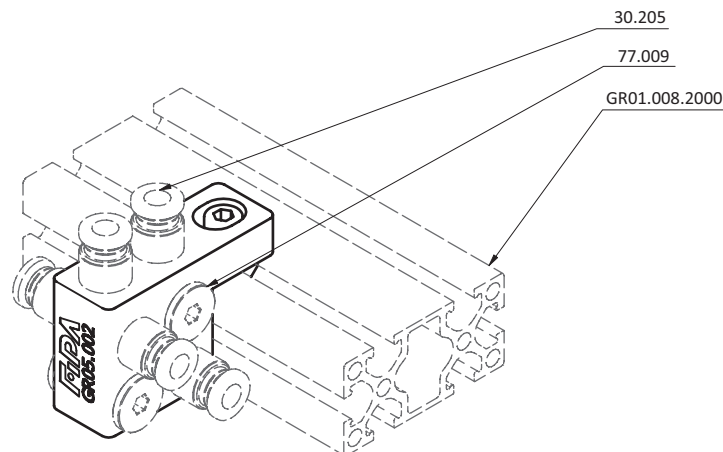

Continued on the next page →



### Dimensions

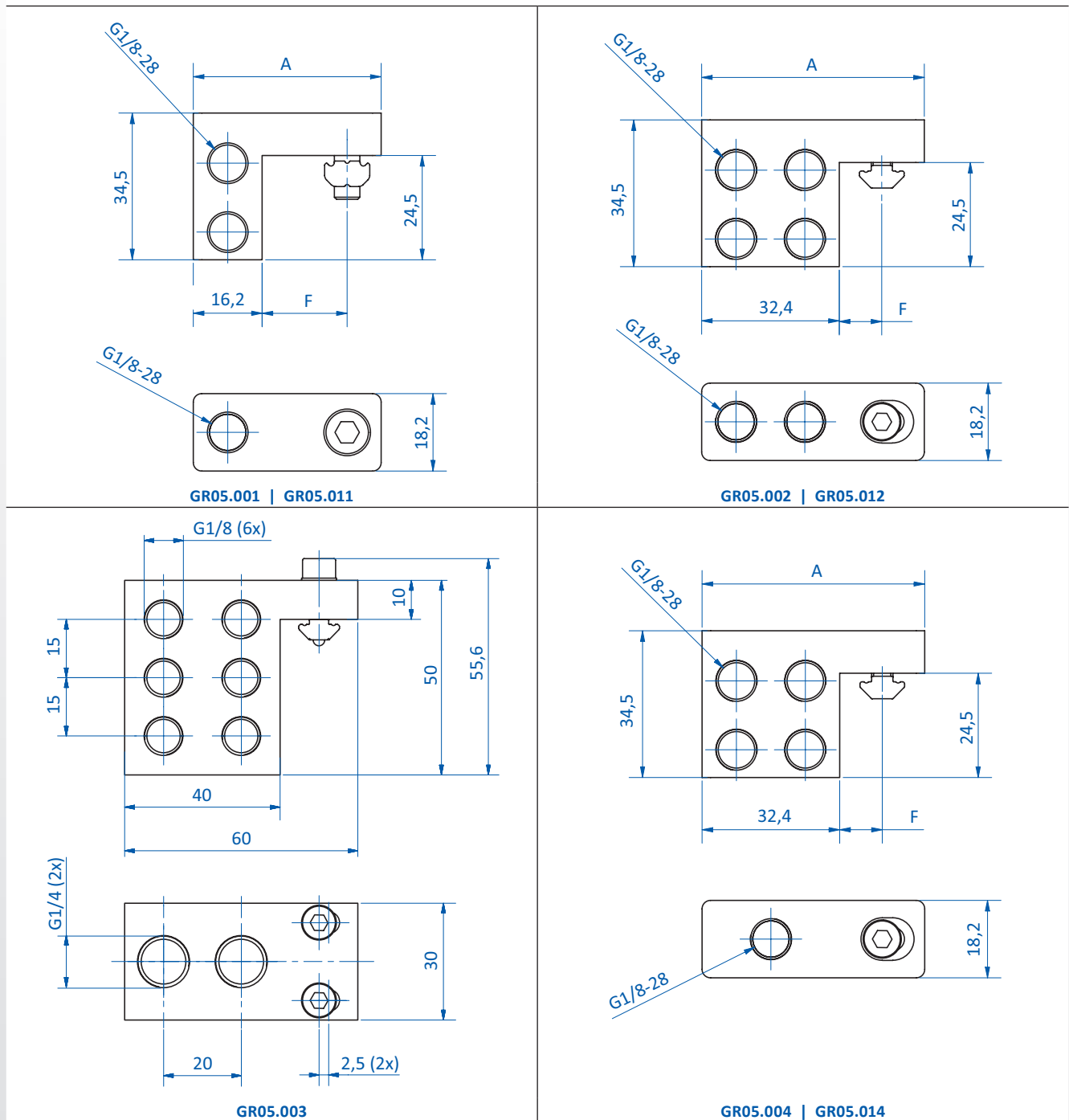

Item no.	A [mm]	F [mm]
GR05.001	36.2	10 - 12.5
GR05.011	44.2	20
GR05.002	52.4	10 - 12.5
GR05.012	60.4	20
GR05.003	--	--
GR05.004	52.4	10 - 12.5
GR05.014	60.4	20



### Air and vacuum manifolds – stackable

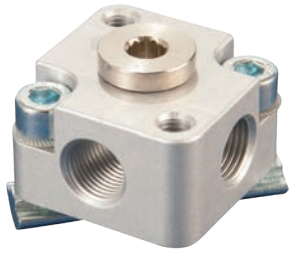

#### Product notes

- > Space-saving distribution of air or vacuum
- > One inlet, four outlets per manifold
- > Can be expanded by stacking additional manifolds
- > When stacking the air manifold, a bore hole with max.  $\varnothing$  7 mm is to be provided in the center of the underside
- > Slot nut, O-ring for sealing and sealing plug included in scope of delivery

#### Technical data

Item no.	Suitable for extrusion system	Circuit	Number of inlets / outlets	Weight [g]	Suitable sealing plugs
GR05.001A	SLine / MLine / JLine	1	1 inlet, 4 outlets	50	77.009

#### Dimensions

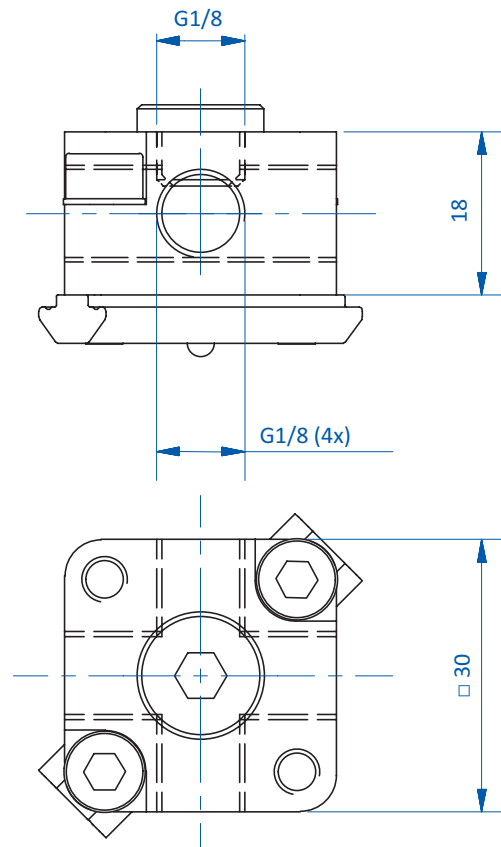



### Swivelling unit – universal, double-acting

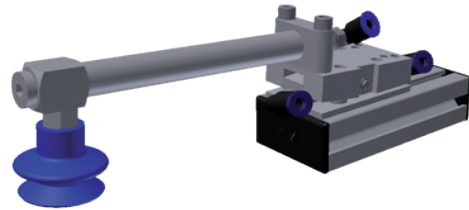

#### Product notes

- > Space-saving lateral application of vacuum cups to the workpiece
- > Double-acting, controlled swivel movement and short duty cycles

#### Technical data

Item no.	Principle of operation	Pressure range [bar (psi)]	Stroke [°]	Weight [g]
GR02.300	double-acting	2 - 8 (29 - 116)	7.5	120

#### Dimensions

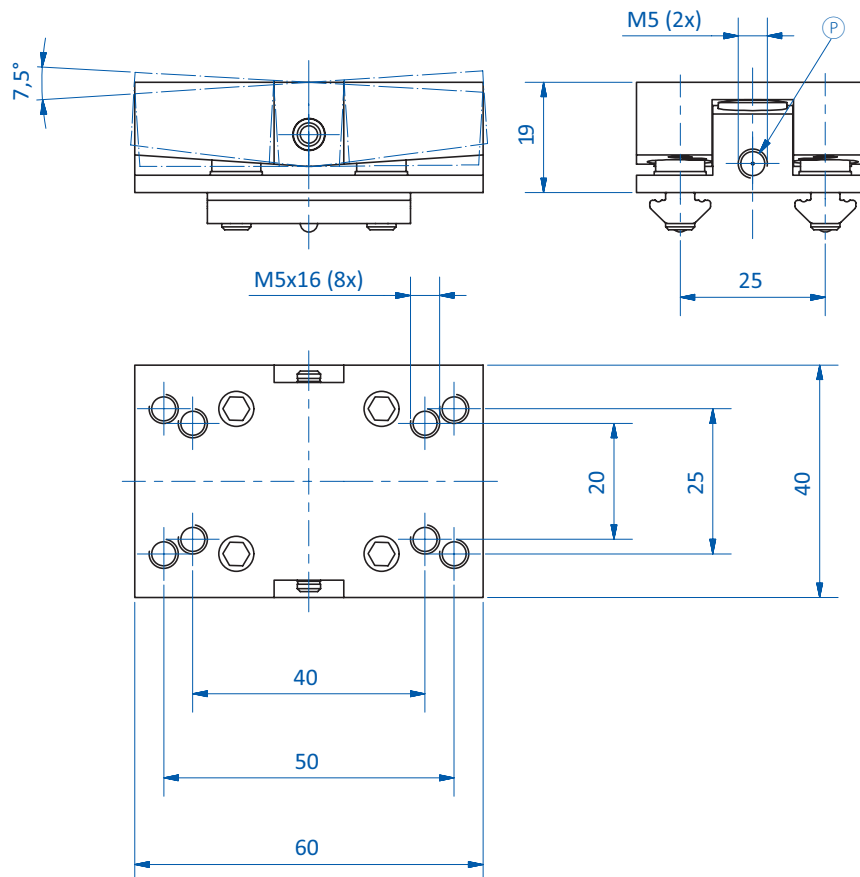

Ⓟ = Compressed air connection



90° Swivelling unit for small gripper systems



**Product notes**

- > Single acting, spring return
- > Optionally available sensors GS04.005 (2x PNP) and GS04.006 (2x NPN) can be taught with two switching points, output M8 4-pole
- > Suitable connection cable (5 m): 20.501

**Technical data**

<b>Item no.</b>	<b>GR04.048</b>
<b>Operating pressure [bar (psi)]</b>	2 - 8 (29 - 116)
<b>Clamping Ø [mm]</b>	30
<b>Stroke [°]</b>	90
<b>Sensor nut</b>	Yes
<b>Torque Rückstellung [Ncm]</b>	276
<b>Torque Schwenken at 6 bar (87 psi) [Ncm]</b>	32
<b>Weight [g]</b>	235
<b>Accessories</b>	Sensor: GS04.005 Sensor: GS04.006 Connecting cable: 20.501

Continued on the next page →



### Application example

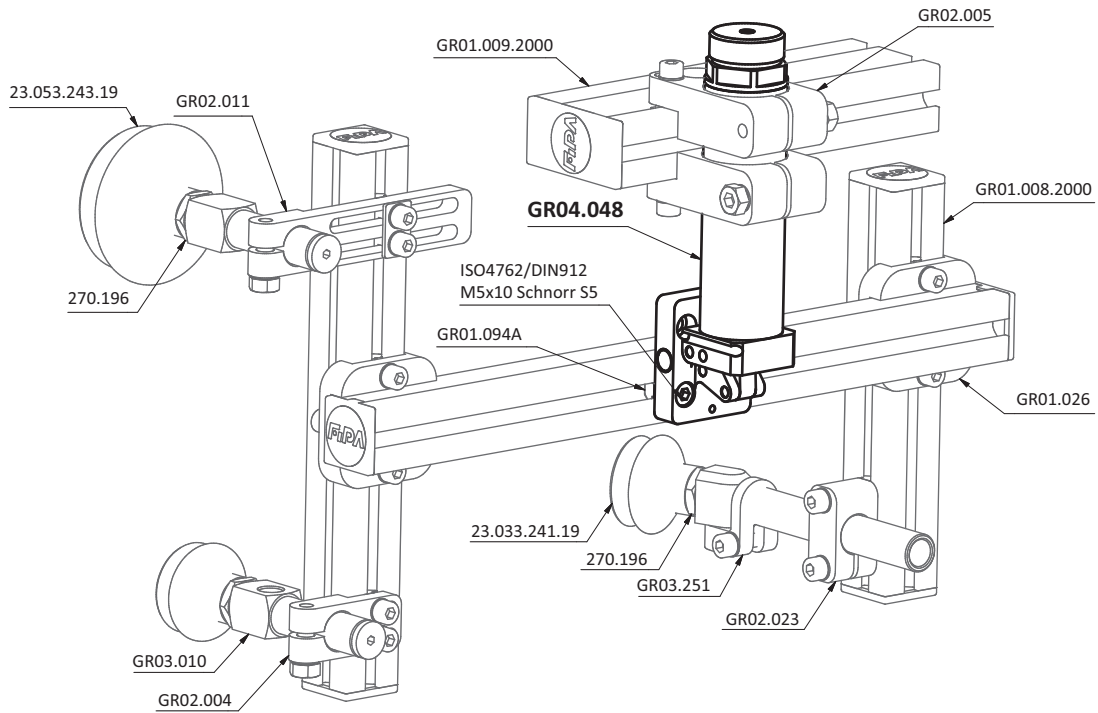

### Dimensions

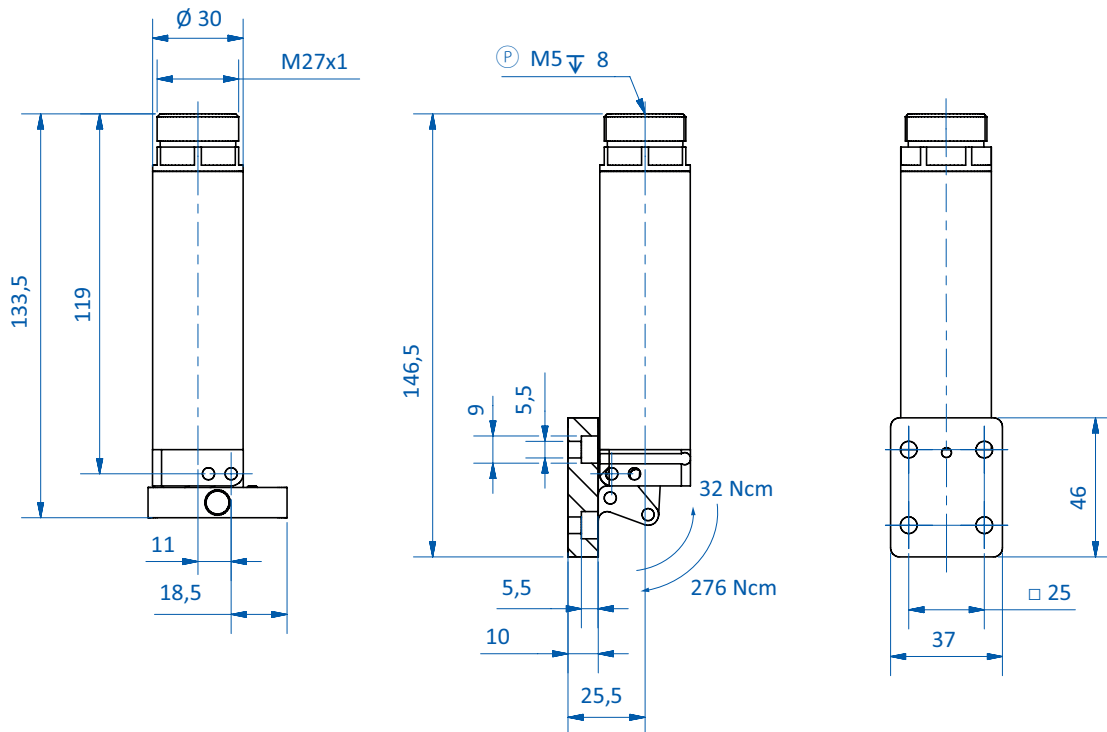

Ⓟ = Compressed air connection



Pneumatic centering units, single acting

**STRONG HOLDING FORCE**



**Product notes**

- > Single-acting centering element for docking with the mold
- > Use for locking the gripper in place while placing inserts or demolding with high force
- > Optional PNP/NPN Sensors can be used to detect locking and/or unlocking
- > Bushing can be mounted from either side in the mold
- > Guiding sleeve not included in the scope of delivery

**Technical data**

Item no.	Suitable guiding sleeve	Clamping $\varnothing$ [mm]	Holding force at 6 bar (87 psi) [N]	Accessories
<b>GR07.520-14</b>	GR07.521-14	14	400	Sensor: GR04.198 Sensor: GR04.198/NPN Sensor mounting bracket: GR04.038S
<b>GR07.520</b>	GR07.521	20	750	Sensor: GR04.198 Sensor: GR04.198/NPN Sensor mounting bracket: GR07.520S

Continued on the next page →



### Dimensions

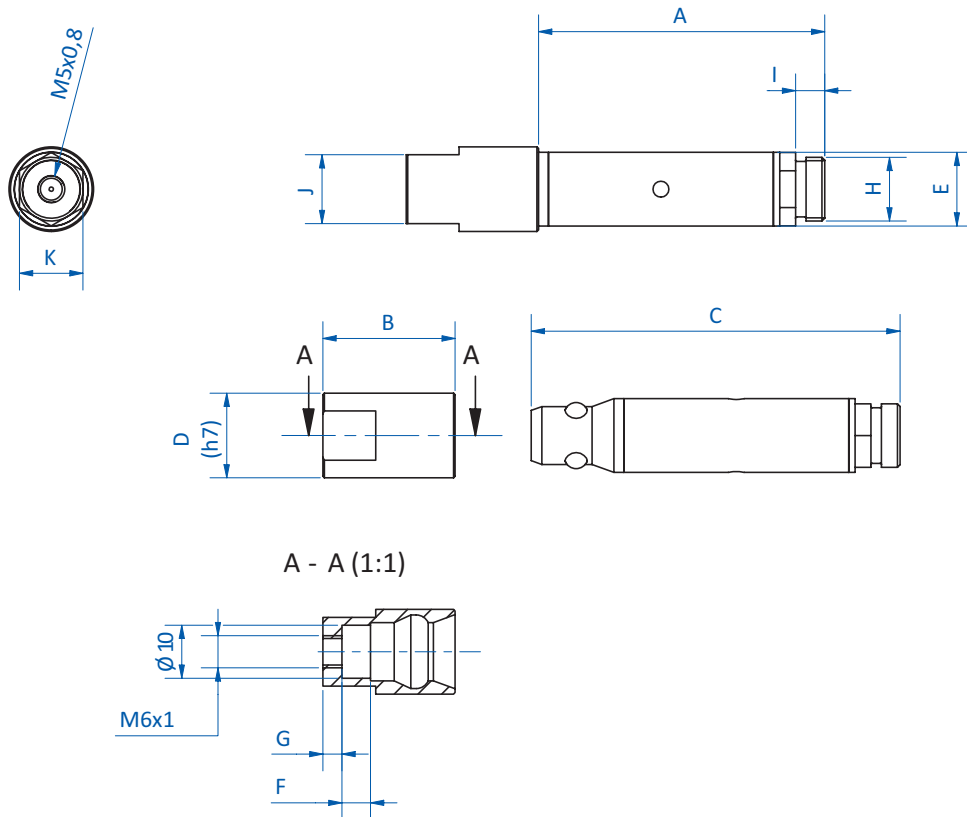

Item no.	Guiding sleeve	A [mm]	B [mm]	C [mm]	Ø D [mm]	E [mm]	F [mm]	G [mm]	H	I [mm]	J [mm]	K [mm]
<b>GR07.520-14</b>	GR07.521-14	54	25	70	16	14	5.4	4	M12x1	5.5	13	12
<b>GR07.520</b>	GR07.521	75	33	96	26	20	5.4	4.6	M17x1	8	--	17





Sensor mounting bracket for centering unit



Display with centering unit

Product notes

> Mounting bracket for monitoring locking stage (locked/unlocked)

Technical data

Item no.	Suitable sensor	Suitable for centering unit	Weight [g]
GR07.520S	GR04.198, GR04.198/NPN	GR07.520	7

Dimensions

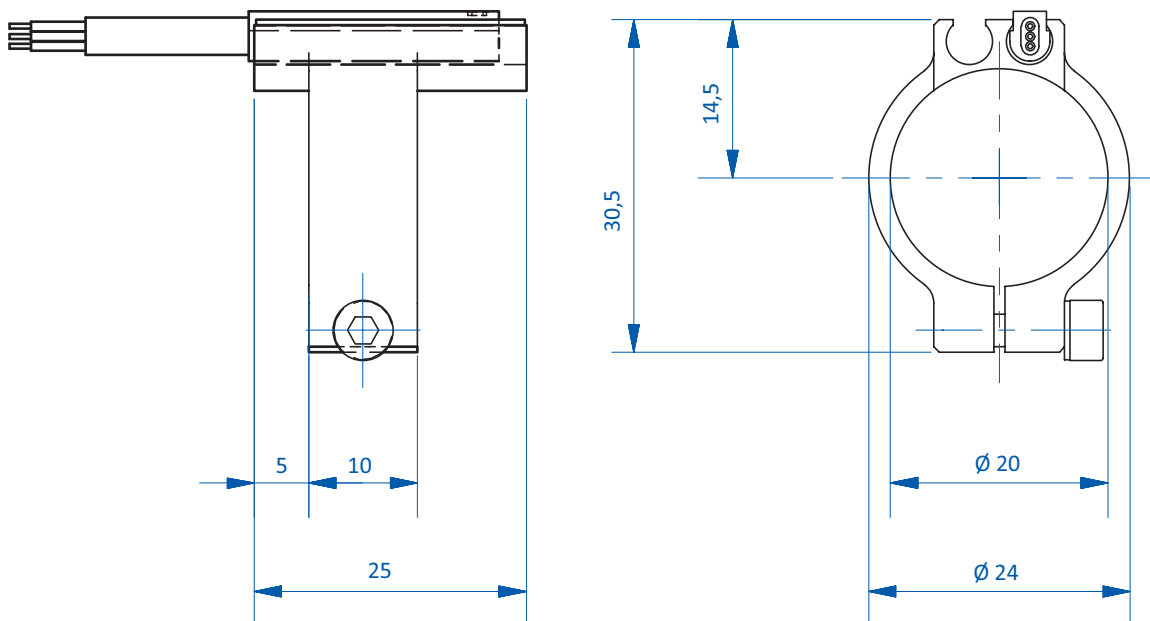



### Clamps for Plate-based EOAT



SUITABLE FOR PLATE-BASED EOAT

#### Product notes

> Clamps for mounting gripper components to plate-based EOAT

#### Technical data

Item no.	Weight [g]
GR06.060	16
GR06.061	24
GR06.062	82
GR06.063	138

#### Dimensions

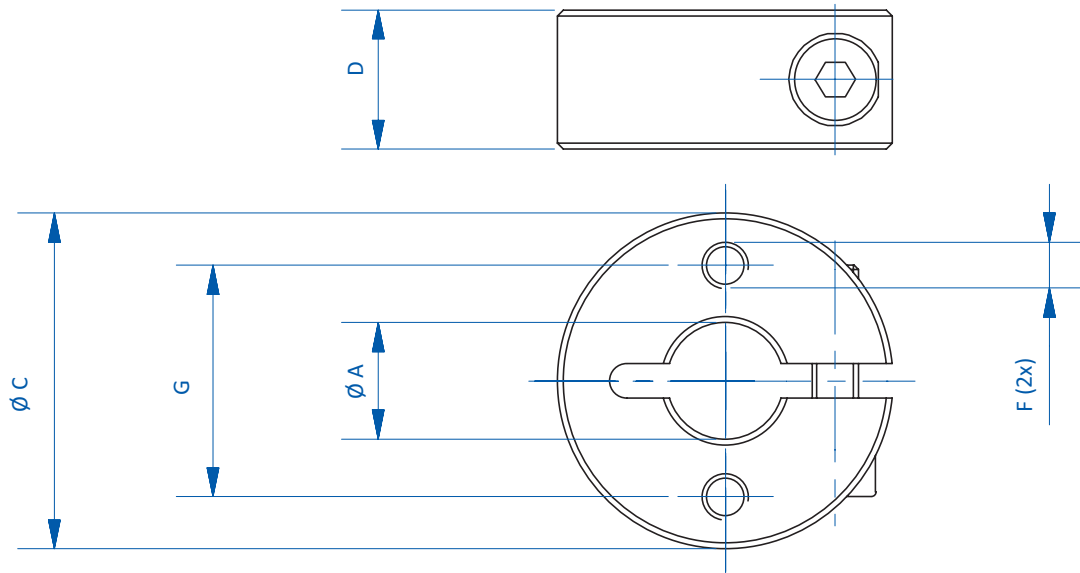

Item no.	Ø A [mm]	F	G [mm]	Ø C [mm]	D [mm]
GR06.060	10	M4	20	29	12
GR06.061	14	M5	25	34	15
GR06.062	20	M6	32	49	22.5
GR06.063	30	M8	45	59	30

Elbow arms – spring compensated ..... 114

Elbow arms – rigid ..... 117

Suction fingers – spring compensated ..... 122

Suction fingers – rigid ..... 125

Extension tubes ..... 129



# Gripper arms | Elbow arms – spring compensated

Elbow arms – spring compensated and non-rotating

## Elbow arms – spring compensated and non-rotating



### Product notes

- > Components for mounting grippers and other gripping elements
- > Spring compensates for variation in ejection stroke
- > Angle adjustment +/- 130°
- > Smooth motion due to lubrication-free polymer bearing

### Technical data

Item no.	Stroke [mm]	Weight [g]
GR03.160	10	60
GR03.161	20	65
GR03.162	15	125
GR03.163	35	134
GR03.164	20	288
GR03.165	40	310

### Dimensions

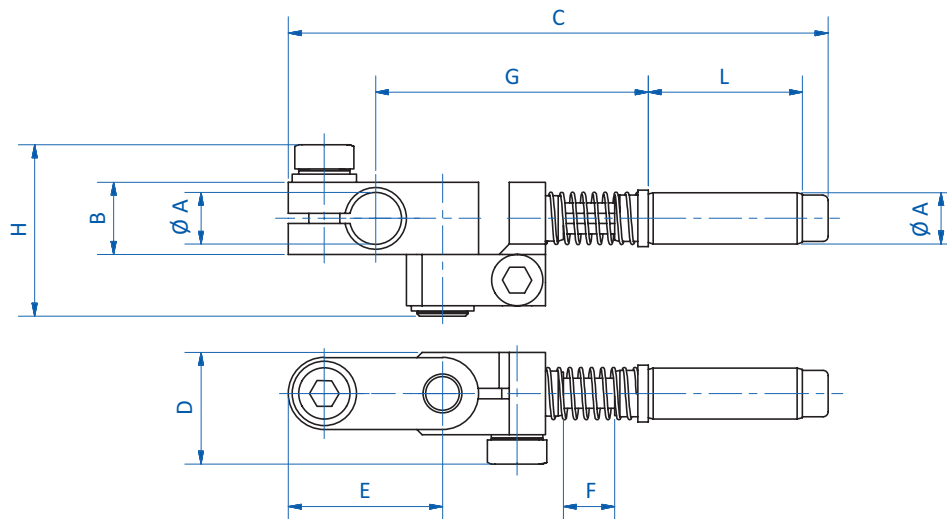

Item no.	Ø A [mm]	B [mm]	C [mm]	D [mm]	E [mm]	F [mm]	G [mm]	H [mm]	L [mm]
GR03.160	10	14	105	22.7	30	10	53	34.3	30
GR03.161	10	14	115	22.7	30	20	63	34.3	30
GR03.162	14	20	133	25.7	37.5	15	69.5	38.7	35
GR03.163	14	20	153	25.7	37.5	35	89.5	38.7	35
GR03.164	20	25	179.5	31.7	52	20	87.5	43.7	55
GR03.165	20	25	199.5	31.7	52	40	107.5	43.7	55

# Gripper arms | Elbow arms – spring compensated

Elbow arms with sliding bush – spring compensated, swivel and non-rotating



Elbow arms with sliding bush – spring compensated, swivel and non-rotating

PRECISE FUNCTIONING EVEN UNDER HIGH LOAD

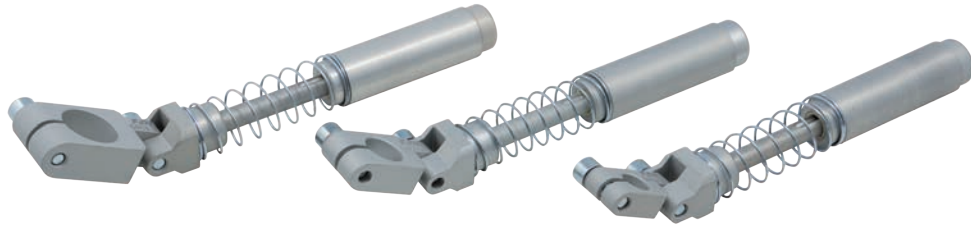

## Product notes

- > Elements for connecting grippers and other gripping elements
- > Guiding through sliding bushes for high precision by absorbing lateral forces and moments
- > Spring compensates for variation in ejection stroke

## Technical data

Item no.	Suitable for grippers with clamping $\varnothing$ [mm]	Stroke [mm]	Weight [g]
GR03.202	10	40	104
GR03.203	14	40	111
GR03.204	20	40	122

## Dimensions

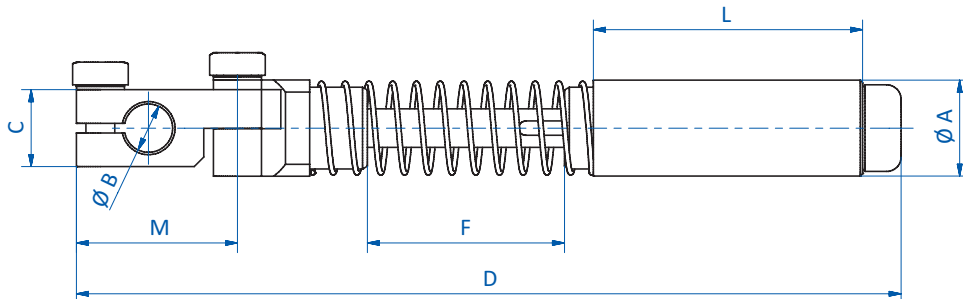

Item no.	$\varnothing A$ [mm]	$\varnothing B$ [mm]	C [mm]	D [mm]	F [mm]	L [mm]	M [mm]
GR03.202	20	10	16	171.5	40	55.5	33.5
GR03.203	20	14	20	177.5	40	55.5	39.5
GR03.204	20	20	25	185.5	40	55.5	47.5



# Gripper arms | Elbow arms – spring compensated

Gripper arm for sprue gripper – spring compensated, non rotating

Gripper arm for sprue gripper – spring compensated, non rotating



## Product notes

- > Spring compensates for variation in ejection stroke
- > Compressed air feed-through for clean & easy installation

## Technical data

Item no.	Suitable for grippers with clamping $\varnothing$ [mm]	Stroke [mm]	Compressed air connection	Weight [g]
<b>GR03.270</b>	10	15	M5	47
<b>GR03.271</b>	20	20	G1/8	140

## Dimensions

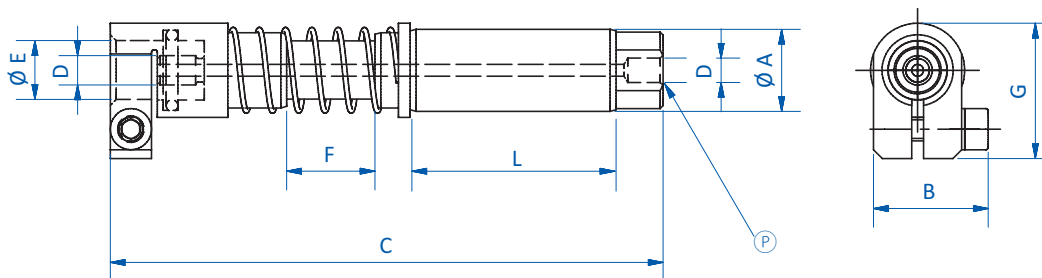

Ⓟ = Compressed air connection

Item no.	$\varnothing A$ [mm]	B [mm]	C [mm]	D	$\varnothing E$ [mm]	F [mm]	G [mm]	L [mm]
<b>GR03.270</b>	14	19.5	94	M5	10	15	23	35
<b>GR03.271</b>	20	25	155	G1/8	20	20	31.5	55



Angle arms – rigid

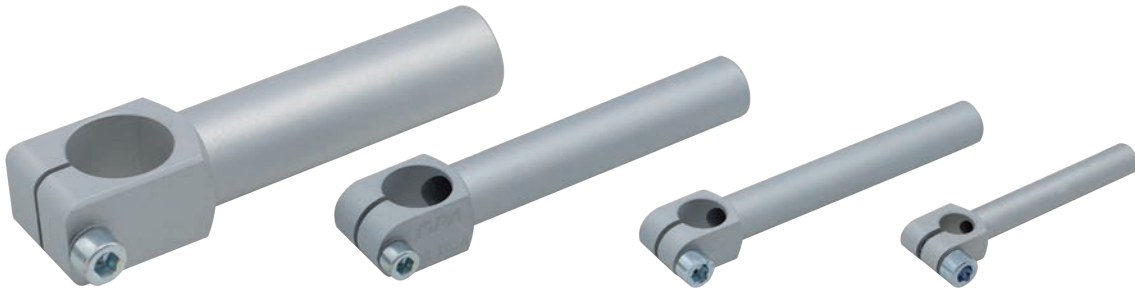

Product notes

> Components for mounting grippers and other gripping elements

Technical data

Item no.	Weight [g]
GR02.070A	20
GR02.071A	24
GR02.072A	28
GR02.083	36
GR02.084	45
GR02.085	52
GR02.100A	61
GR02.101A	80
GR02.102A	95
GR02.104	137
GR02.105	171
GR02.106	205
GR02.107	239
GR02.108	12
GR02.109	17.8
GR02.120	32.7
GR02.121	97.2

Dimensions

$\varnothing A$ [mm]	B [mm]	C [mm]	D [mm]	G [mm]	H [mm]	$\varnothing J$ [mm]	L [mm]
10	16	51	16	7	22.7	10	30
10	16	81	10	7	22.7	10	60
10	16	111	16	7	22.7	10	90
14	18	70.5	20	9.5	24.7	14	45
14	18	115.5	20	9.5	24.7	14	90
14	18	155.5	20	9.5	24.7	14	130
20	24	84	25	13	30.7	20	50
20	24	134	25	13	31.7	20	100
20	24	184	25	13	31.7	20	150
30	36	98	30	21	44.8	30	50
30	36	148	30	21	44.8	30	100
30	36	198	30	21	44.8	30	150
30	36	248	30	21	44.8	30	200
10	16	36	10	7	22.7	10	15
14	18	45.5	14	9.5	24.7	14	20
20	24	59	20	13	30.7	20	25
30	36	73	30	21	44.8	20	25

Dimensions

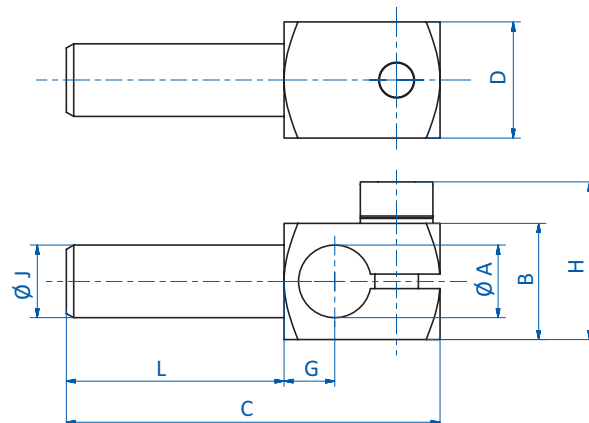



# Gripper arms | Elbow arms – rigid

## Elbow arms – swivel

### Elbow arms – swivel

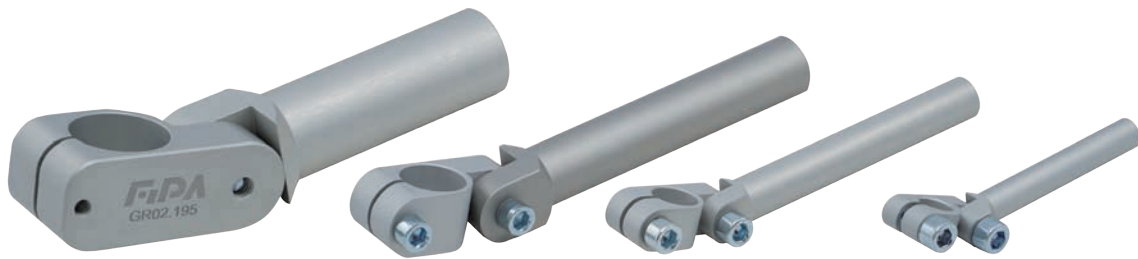

#### Product notes

- > Components for mounting grippers and other gripping elements
- > Angle adjustment +/- 95°

#### Technical data

Item no.	Weight [g]
GR02.140	36
GR02.141	40
GR02.142	45
GR02.180	42
GR02.181	51
GR02.182	59
GR02.153	60
GR02.154	68
GR02.155	78
GR02.170	87
GR02.171	103
GR02.172	120
GR02.195	193
GR02.196	217
GR02.197	243

#### Dimensions

$\varnothing A$ [mm]	$\varnothing F$ [mm]	B [mm]	C [mm]	E [mm]	G [mm]	H [mm]	L [mm]
10	10	16	65.5	8.5	22	22.7	30
10	10	16	95.5	8.5	22	22.7	60
10	10	16	125.5	8.5	22	22.7	90
14	10	16	90	10	27	22.7	45
14	10	16	135	10	27	22.7	90
14	10	16	175	10	27	22.7	130
14	14	18	90	10	27	24.7	45
14	14	18	135	10	27	24.7	90
14	14	18	175	10	27	24.7	130
20	20	24	111	17	40	30.7	50
20	20	24	161	17	40	30.7	100
20	20	24	211	17	40	30.7	150
30	30	36	162	22	56	--	80
30	30	36	222	22	56	--	140
30	30	36	282	22	56	--	200

#### Dimensions

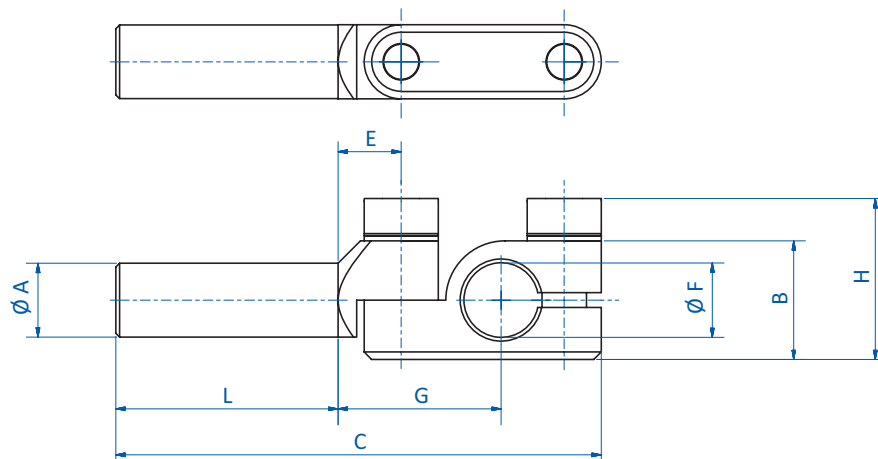





Elbow arms – swivel, heavy duty



Product notes

- > Components for mounting grippers and other gripping elements
- > Secure clamping under heavy load
- > Angle adjustment +/- 100°
- > Heads are interchangeable with the heads of suction fingers GR03.240 - GR03.242, GR03.250 - GR03.252 und GR03.260 - GR03.262

Technical data

Dimensions

Item no.	Weight [g]	∅ A [mm]	B [mm]	C [mm]	D [mm]	E [mm]	F [mm]	G [mm]	H [mm]	L [mm]
GR02.240	29	10	14	72	14	14	4.5	26	31.7	30
GR02.241	32	10	14	102	14	14	4.5	26	31.7	60
GR02.242	35	10	14	132	14	14	4.5	26	31.7	90
GR02.250	50	14	18	97	18	16	4.5	34	33.7	45
GR02.251	58	14	18	142	18	16	4.5	34	33.7	90
GR02.252	66	14	18	182	18	16	4.5	34	33.7	130
GR02.260	89	20	24	116	24	19	4.5	43	39.7	50
GR02.261	104	20	24	166	24	19	4.5	43	39.7	100
GR02.262	119	20	24	216	24	19	4.5	43	39.7	150

Dimensions

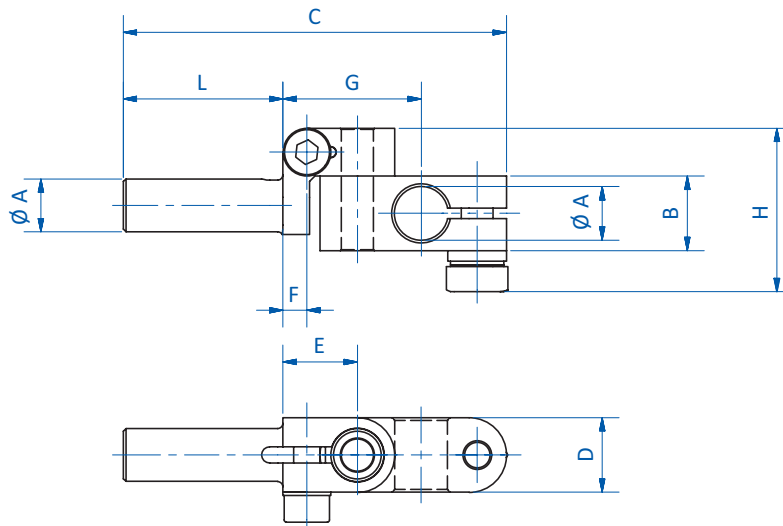



# Gripper arms | Elbow arms – rigid

Elbow arms – swivel, extra heavy duty

## Elbow arms – swivel, extra heavy duty



### Product notes

- > Secure clamping under heavy load
- > Angle adjustment 0 – 90°

### Technical data

Item no.	Weight [g]
GR02.310	27
GR02.311	30
GR02.312	33
GR02.313	62
GR02.314	70
GR02.315	78
GR02.316	150
GR02.317	165
GR02.318	180
GR02.319	461
GR02.320	502
GR02.321	546

### Dimensions

$\varnothing$ A [mm]	B [mm]	C [mm]	D [mm]
10	30	74	20
10	60	104	20
10	90	134	20
14	40	99	28
14	80	139	28
14	120	179	28
20	50	129	40
20	100	179	40
20	150	229	40
30	80	190	60
30	140	250	60
30	200	310	60



### Application example

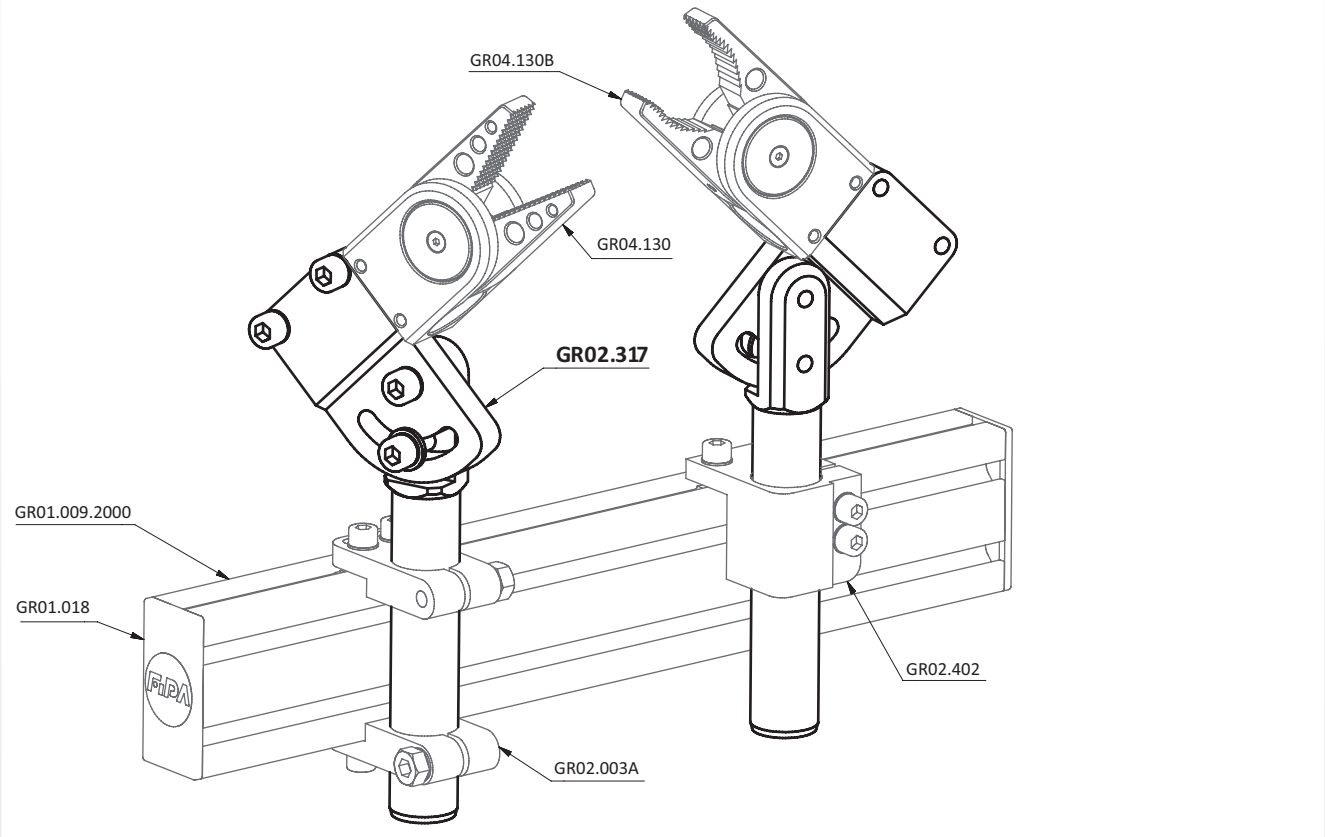

### Dimensions

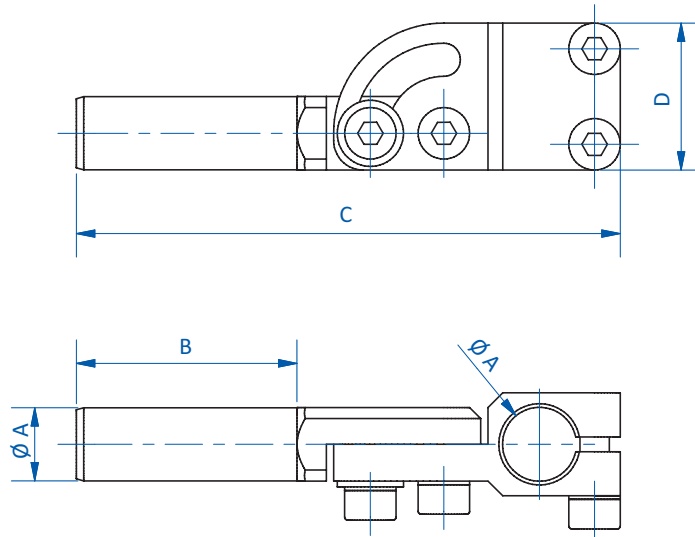



# Gripper arms | Suction fingers – spring compensated

Spring compensated gripper arm for vacuum cups

## Spring compensated gripper arm for vacuum cups



### Product notes

- > Spring compensates for variation in ejection stroke
- > Smooth motion due to lubrication-free polymer bearing
- > Only for round vacuum cups

Technical data			Dimensions									
Item no.	Stroke [mm]	Weight [g]	$\varnothing A$ [mm]	G	H	D	$\square B$ [mm]	C [mm]	E [mm]	F [mm]	L [mm]	
GR03.080A	10	18	10	M5	M5	--	10	67	31.5	10	25	
GR03.081A	20	18	10	M5	M5	--	10	77	41.5	20	25	
GR03.090A	15	45	14	G1/8	G1/8	M5	16	92.5	41.1	15.1	35	
GR03.091A	35	48	14	G1/8	G1/8	M5	16	112.5	61.1	35.1	35	
GR03.114	20	127	20	G1/8	G1/4	G1/8	20	127.5	50	20	55	
GR03.115	40	136	20	G1/8	G1/4	G1/8	20	147.5	70	40	55	

### Dimensions

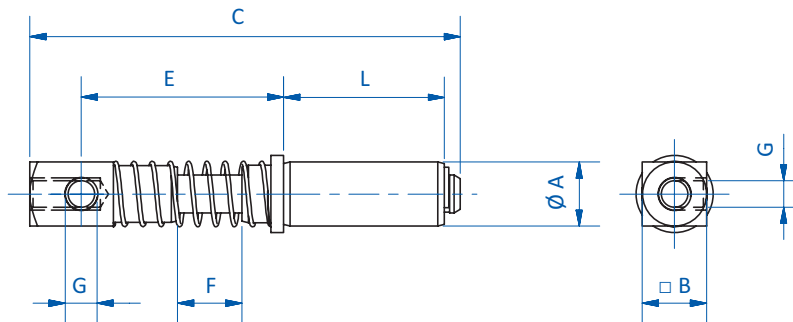

GR03.080A | GR03.081A

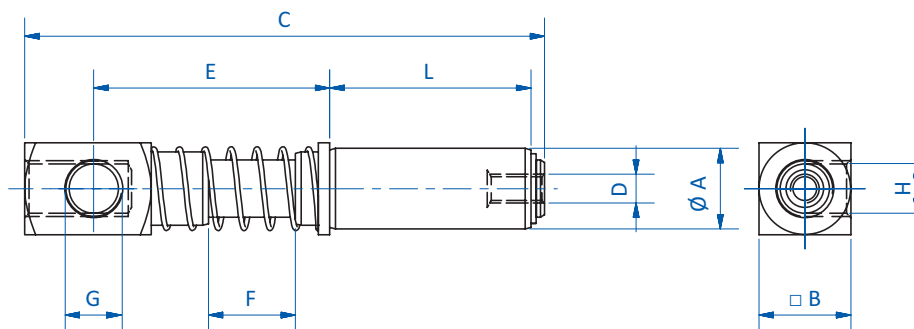

GR03.090A | GR03.091A | GR03.114 | GR03.115



### Spring compensated gripper arm for vacuum cups – non-rotating

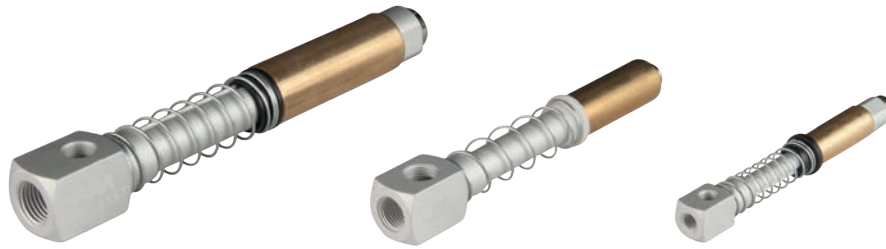

#### Product notes

- > Spring compensates for variation in ejection stroke
- > Smooth motion due to lubrication-free polymer bearing
- > Suitable for round, oval and rectangular vacuum cups
- > Lateral vacuum port or at the end

#### Technical data

Item no.	Stroke [mm]	Weight [g]
GR03.080T	10	17
GR03.081T	20	18
GR03.090T	15	44
GR03.091T	35	48
GR03.114T	20	129
GR03.115T	40	137

#### Dimensions

$\varnothing A$ [mm]	G	H	D	$\square B$ [mm]	C [mm]	E [mm]	F [mm]	L [mm]
10	M5	M5	M5	10	75	31.5	10	25
10	M5	M5	M5	10	85	41.5	20	25
14	G1/8	G1/8	M5	16	98.5	41.1	15	35
14	G1/8	G1/8	M5	16	118.5	61	35	35
20	G1/8	G1/4	G1/8	20	137.5	50	20	55
20	G1/8	G1/4	G1/8	20	157	70	40	55

#### Dimensions

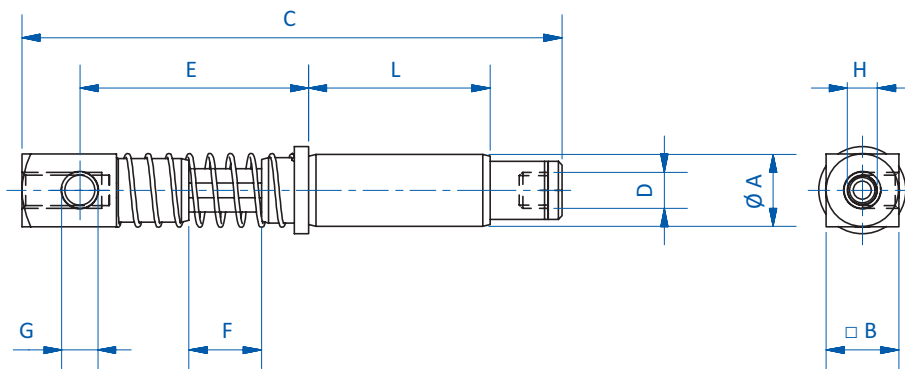



# Gripper arms | Suction fingers – spring compensated

Spring compensated suction fingers for vacuum cups – non-rotating, swivel

Spring compensated suction fingers for vacuum cups – non-rotating, swivel

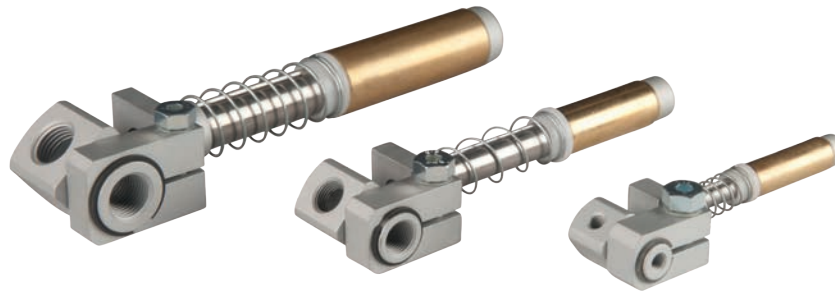

## Product notes

- > Adjustable head for mounting and aligning vacuum cups with part contours
- > Spring compensates for variation in ejection stroke
- > Smooth motion due to lubrication-free polymer bearing
- > Angle adjustment +/- 120°

## Technical data

Item no.	Stroke [mm]	Weight [g]
<b>GR03.120B</b>	10	35
<b>GR03.121B</b>	20	37
<b>GR03.130B</b>	15	75
<b>GR03.131B</b>	35	84
<b>GR03.152B</b>	20	207
<b>GR03.153B</b>	40	229

## Dimensions

$\varnothing A$ [mm]	E	B [mm]	C [mm]	D [mm]	F [mm]	$\square G$ [mm]	H [mm]	L [mm]
10	M5	16	82	26	10	14	21.7	30
10	M5	16	92	26	20	14	21.7	30
14	G1/8	19	104.5	32.5	15	18	24.7	35
14	G1/8	19	124.5	32.5	35	18	24.7	35
20	G1/4	25	139.5	37.5	20	24	30.7	55
20	G1/4	25	159.5	37.5	40	24	30.7	55

## Dimensions

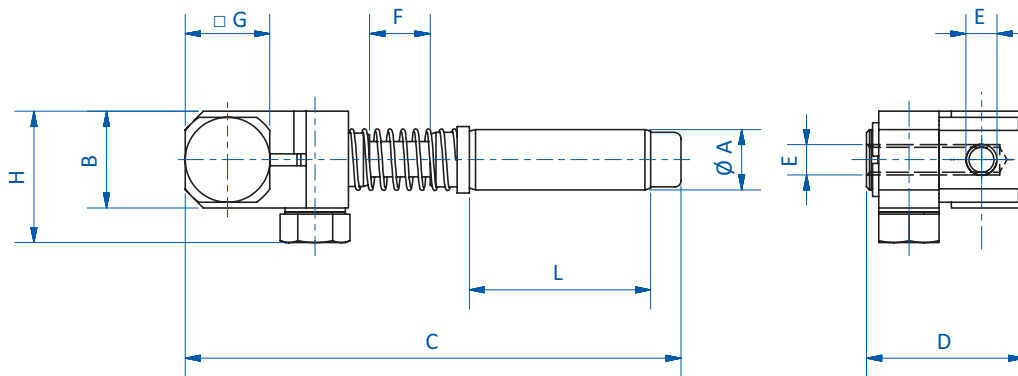



### Suction fingers for vacuum cups – rigid



#### Product notes

- > Components for mounting vacuum cups
- > Two vacuum ports

#### Technical data

Item no.	Weight [g]
GR03.001A	11
GR03.002A	16
GR03.003A	22
GR03.006	13
GR03.007	18
GR03.009	24
GR03.010A	27
GR03.011A	39
GR03.012A	49
GR03.036	64
GR03.037	100
GR03.038	137

#### Dimensions

$\varnothing A$ [mm]	F	G	H	$\square B$ [mm]	E [mm]	C [mm]	L [mm]
10	M5	--	--	12	13	45.5	30
10	M5	--	--	12	13	75	60
10	M5	--	--	12	13	105	90
10	G1/8	M5	M5	14	18	50	30
10	G1/8	M5	M5	14	18	80	60
10	G1/8	M5	M5	14	18	110	90
14	G1/8	--	--	16	20	67.5	45
14	G1/8	--	--	16	20	112.5	90
14	G1/8	--	--	16	20	152.5	130
20	G1/4	G1/8	G1/8	22	23	75.5	50
20	G1/4	G1/8	G1/8	22	23	125	100
20	G1/4	G1/8	G1/8	22	23	175.5	150

Continued on the next page →



# Gripper arms | Suction fingers – rigid

Suction fingers for vacuum cups – rigid

## Dimensions

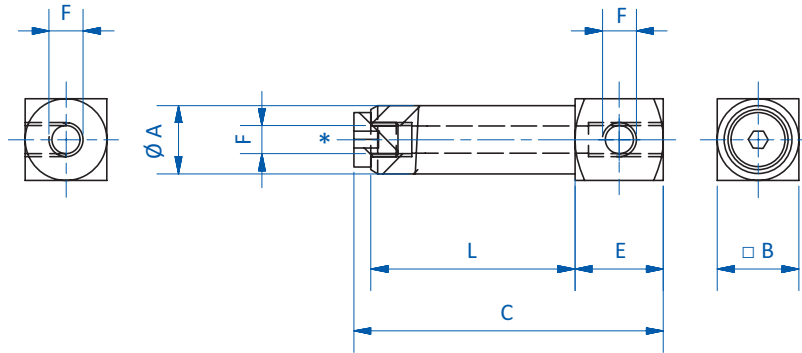

GR03.001A | GR03.002A | GR03.003A | GR03.010A | GR03.011A | GR03.012A

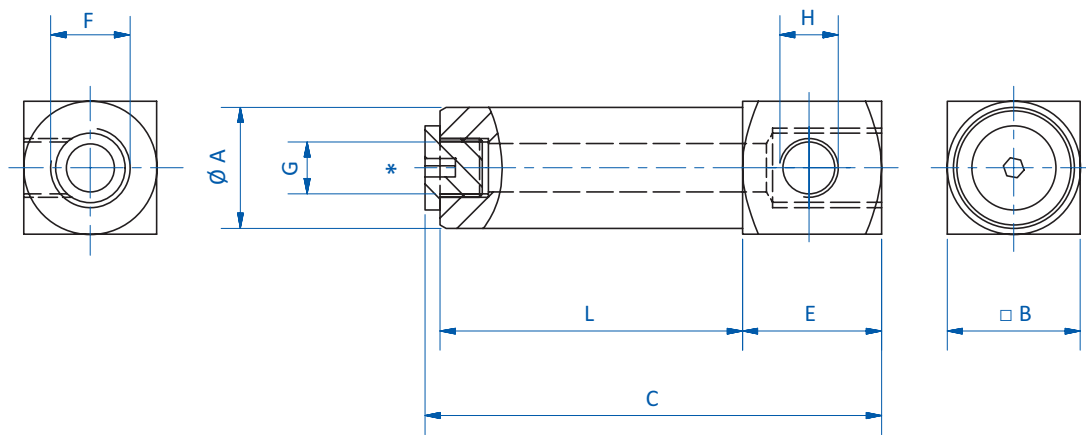

GR03.006 | GR03.007 | GR03.009 | GR03.036 | GR03.037 | GR03.038

\* = Alternative vacuum connection





### Suction fingers – swivel, lightweight design



#### Product notes

- > Adjustable head for mounting and aligning vacuum cups with part contours
- > Angle adjustment +/- 100°
- > Up to 50 % less weight compared to standard version
- > Heads are interchangeable with the heads of elbow arms GR02.240 - GR02.242, GR02.250 - GR02.252, GR02.260 - GR02.262

#### Technical data

Item no.	Weight [g]
GR03.240	15
GR03.241	18
GR03.242	21
GR03.250	29
GR03.251	37
GR03.252	46
GR03.260	57
GR03.261	71
GR03.262	86

#### Dimensions

$\varnothing A$ [mm]	F	B [mm]	C [mm]	D [mm]	E [mm]	H [mm]	L [mm]
10	M5	20	52	14	14	19.6	30
10	M5	20	82	14	14	19.6	60
10	M5	20	112	14	14	19.6	90
14	G1/8	28	71	18	16	23.6	45
14	G1/8	28	116	18	16	23.6	90
14	G1/8	28	156	18	16	23.6	130
20	G1/4	33	82	24	19	29.6	50
20	G1/4	33	132	24	19	29.6	100
20	G1/4	33	182	24	19	29.6	150

#### Dimensions

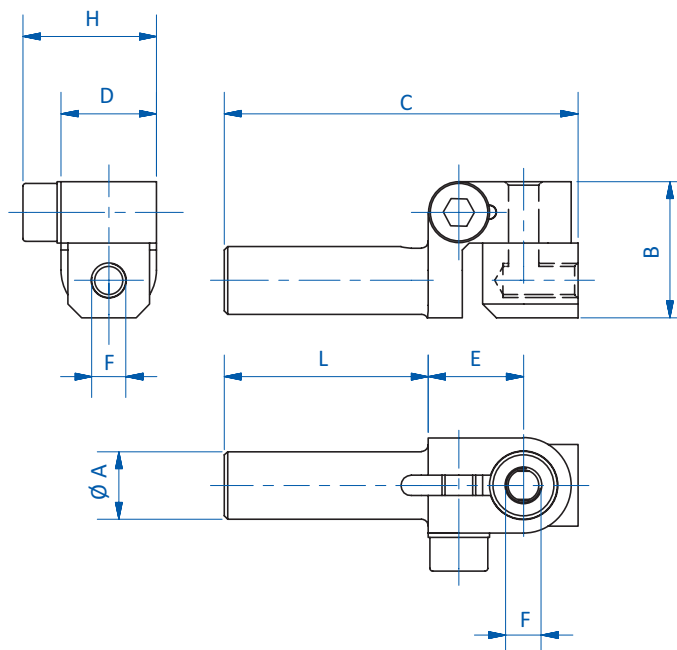



# Gripper arms | Suction fingers – rigid

Vacuum cup elbow – swivel

## Vacuum cup elbow – swivel



### Product notes

- > Swivelling extension for vacuum cups
- > Vacuum only (not for compressed air)

### Technical data

Item no.	Connection thread	Weight [g]
GR03.302	G1/8	7
GR03.303	G1/4	15

### Dimensions

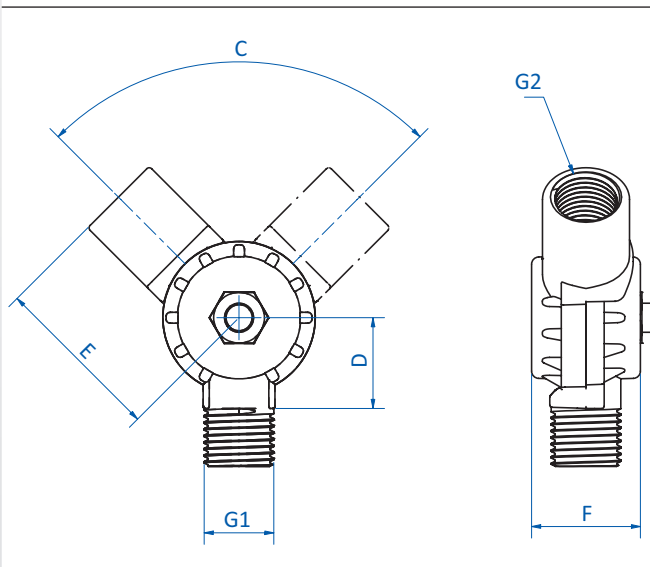

### Application example

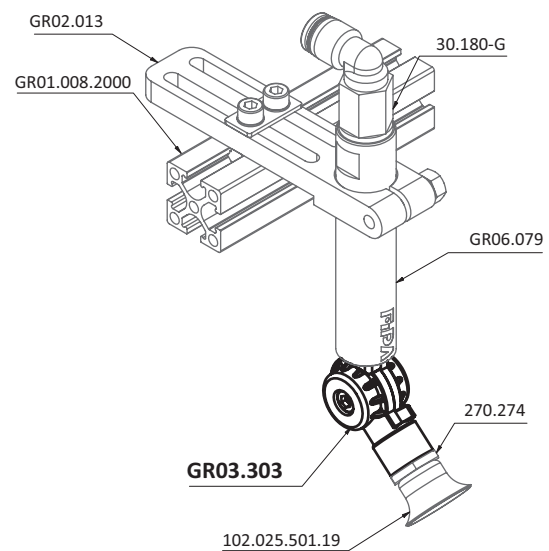

Item no.	G1	G2	C [°]	D [mm]	E [mm]	F [mm]
GR03.302	G1/8	G1/8	90	12.5	23.5	15
GR03.303	G1/4	G1/4	90	16	29	21



Extension tubes



Product notes

> Flexible clampable extension for sprue grippers, finger grippers, centering units and many other components

Technical data

Item no.	Clamping $\phi$ [mm]	Length [mm]	Thread	Weight [g]
GR06.018	10	30	M8x1	3
GR06.019	10	60	M8x1	6
GR06.020	10	100	M8x1	11
GR06.014	14	40	M12x1	6
GR06.021A	14	100	M12x1	16
GR06.015	14	120	M12x1	19
GR06.016	20	50	M17x1	15
GR06.022	20	100	M17x1	30
GR06.017	20	150	M17x1	48
GR06.026	30	100	M27x1	52
GR06.027	30	140	M27x1	73
GR06.028	30	200	M27x1	105

Dimensions

$\phi$ A [mm]	G	C [mm]	B [mm]
10	M8x1	15	30
10	M8x1	15	60
10	M8x1	15	100
14	M12x1	18	40
14	M12x1	18	100
14	M12x1	18	120
20	M17x1	18	50
20	M17x1	18	100
20	M17x1	18	150
30	M27x1	18	100
30	M27x1	18	140
30	M27x1	18	200

Dimensions

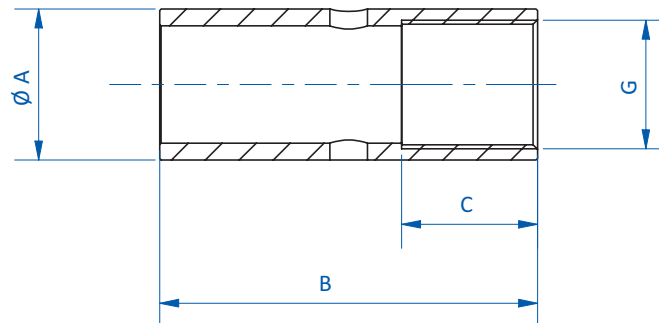



# Gripper arms | Extension tubes

Extension tubes with pneumatic connection

## Extension tubes with pneumatic connection



### Product notes

- > With pneumatic feed-through
- > Multi-purpose extension tube e.g. for sprue grippers, gripper fingers or centering units

### Technical data

Item no.	Clamping $\varnothing$ [mm]	Length [mm]	Connection	Thread	Weight [g]
<b>GR06.023</b>	14	100	M12x1	M5	37
<b>GR06.024</b>	20	100	M17x1	M5	75
<b>GR06.025</b>	30	100	M27x1	M5	168

### Dimensions

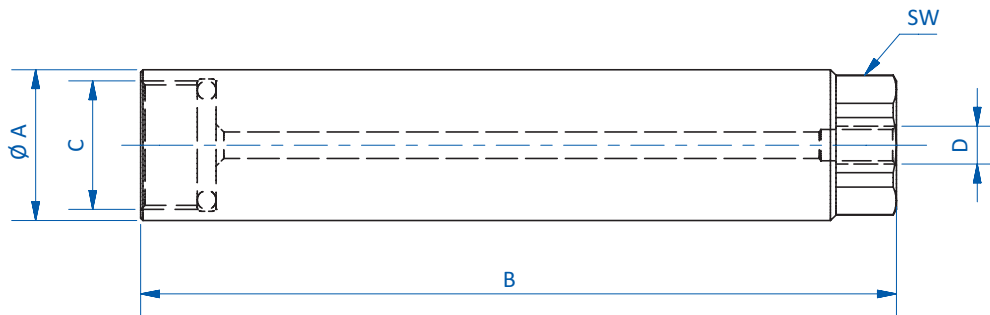

Item no.	$\varnothing$ A [mm]	B [mm]	C	D	SW
<b>GR06.023</b>	14	100	M12x1	M5	12
<b>GR06.024</b>	20	100	M17x1	M5	17
<b>GR06.025</b>	30	100	M27x1	M5	27



### Extension tube with air lead



#### Product notes

- > With pneumatic feed-through
- > Multi-purpose extension tube for vacuum cups

#### Technical data

Item no.	Clamping $\varnothing$ [mm]	Length [mm]	Thread	Weight [g]
GR06.070	10	15	M5	3
GR06.071	10	30	M5	5
GR06.072	10	45	M5	8
GR06.073	10	90	M5	16
GR06.074	14	15	G1/8	5
GR06.075	14	30	G1/8	10
GR06.076	14	45	G1/8	16
GR06.077	14	90	G1/8	31
GR06.078	20	45	G1/4	32
GR06.079	20	90	G1/4	57

#### Dimensions

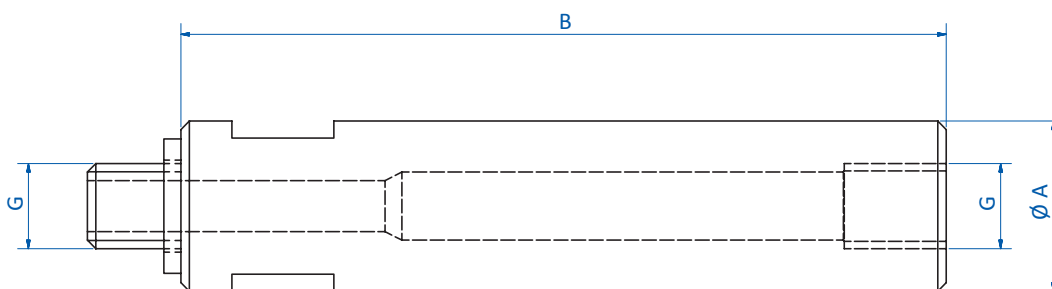

Item no.	$\varnothing A$ [mm]	B [mm]	G
GR06.070	10	15	M5
GR06.071	10	30	M5
GR06.072	10	45	M5
GR06.073	10	90	M5
GR06.074	14	15	G1/8
GR06.075	14	30	G1/8
GR06.076	14	45	G1/8
GR06.077	14	90	G1/8
GR06.078	20	45	G1/4
GR06.079	20	90	G1/4



<b>Sprue grippers</b> .....	<b>134</b>
<b>Power grippers</b> .....	<b>178</b>
<b>Gripper fingers</b> .....	<b>186</b>
<b>Parallel grippers</b> .....	<b>199</b>
<b>Angular grippers</b> .....	<b>221</b>
<b>3-finger grippers</b> .....	<b>229</b>
<b>Elastomer pads</b> .....	<b>234</b>
<b>Expansion grippers</b> .....	<b>238</b>
<b>Needle grippers</b> .....	<b>245</b>
<b>Magnetic grippers</b> .....	<b>261</b>
<b>Bernoulli vacuum cups</b> .....	<b>262</b>



# Grippers | Sprue grippers

Series 60 – miniature grippers, clamping diameter 10 mm – single-acting

## Series 60 – miniature grippers, clamping diameter 10 mm – single-acting



### Product notes

- > Gripper for small sprues and restricted space
- > Gap-free closing
- > Body and jaws made of high-strength anodized aluminum alloy
- > Single-acting
- > Medium: filtered and oiled/unoiled air
- > Ambient air temperature: -20°C to +80°C (-4 °F to 176 °F)

### Technical data

Item no.	Jaw	Max. operating pressure [bar (psi)]	Sensor	Closing force at 6 bar (87 psi) [N]	Weight [g]
GR04.060	Standard	6 (87)	without	3.5	5.3

### Dimensions

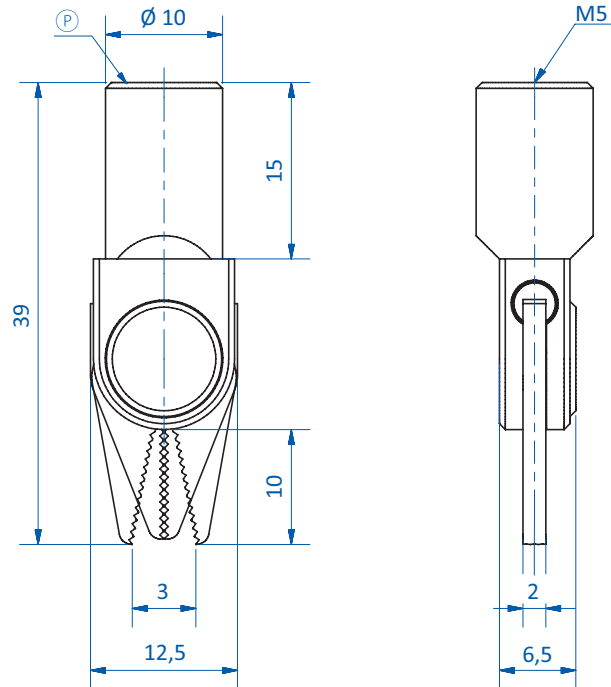

Ⓟ = Compressed air connection





### Series 80 – miniature sprue gripper, clamping diameter 10 mm – single-acting



#### Product notes

- > Clamping diameter 10 mm
- > Body and jaws made of anodized aluminum alloy
- > Model SI with FDA-compliant silicone pad
- > Model H with replaceable HNBR pads for gentle handling
- > Index 1N and 1P for direct monitoring
- > Principle of operation: single-acting
- > Medium: filtered and oiled/unoiled air
- > Ambient air temperature: -20 °C to +80 °C (-4 °F to 176 °F)
- > Ambient air temperature for sprue grippers with sensor: -20°C to +70°C (-4 °F to 158 °F)
- > Usage temperature for HNBR pads 15 to 150 °C (59 to 302 °F), for silicone pads 15 to 200 °C (59 to 392 °F)

#### Technical data

Item no.	Jaw	Max. operating pressure [bar (psi)]	Sensor	Electric connection	Cable length [mm]	Closing force at 6 bar (87 psi) [N]	Weight [g]	Accessories
<b>GR04.080</b>	Standard	6 (87)	without	--	--	12	8	--
<b>GR04.080SI</b>	Silicone pad	6 (87)	without	--	--	12	8	Silicone pad: GR04.080-11S
<b>GR04.080H</b>	HNBR Pad	6 (87)	without	--	--	12	8	HNBR pad: GR04.080-11H
<b>GR04.080-1N</b>	Standard	6 (87)	NPN, direct monitoring, one freely adjustable switching point	3-pin male M8 connector	200	12	12	Connecting cable: 20.503 Connecting cable: 20.507
<b>GR04.080-1P</b>	Standard	6 (87)	PNP, direct monitoring, one freely adjustable switching point	3-pin male M8 connector	200	12	12	Connecting cable: 20.503 Connecting cable: 20.507

Continued on the next page →



# Grippers | Sprue grippers

Series 80 – miniature sprue gripper, clamping diameter 10 mm – single-acting

## Dimensions

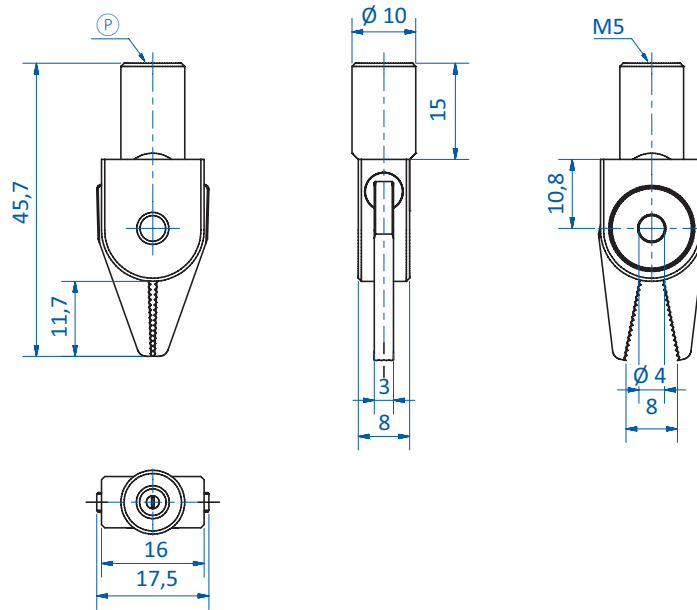

GR04.080

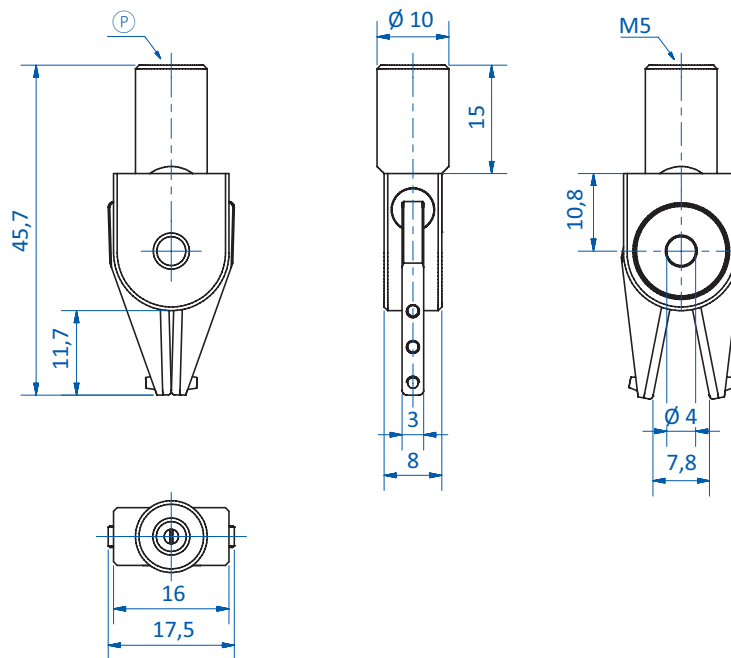

GR04.080SI | GR04.080H

Ⓟ = Compressed air connection



### Dimensions

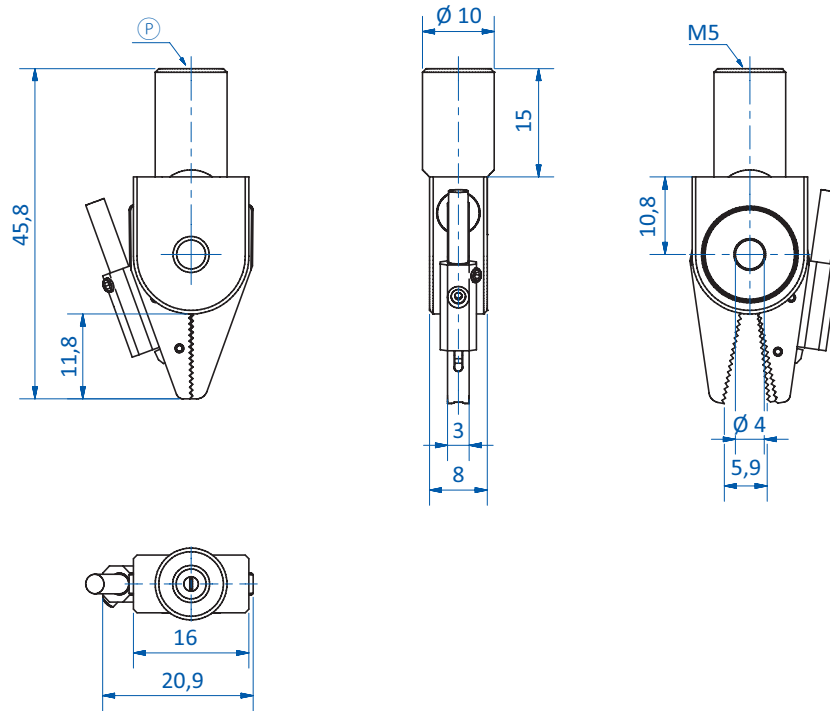

GR04.080-1N | GR04.080-1P

Ⓟ = Compressed air connection



# Grippers | Sprue grippers

Series 90 – miniature sprue grippers, clamping diameter 10 mm – single-acting

## Series 90 – miniature sprue grippers, clamping diameter 10 mm – single-acting



### Product notes

- > Grippers for small gates and limited space requirement
- > High gripping force and wide jaw opening
- > Housings and gripper jaws consist of an anodized, high-strength aluminum alloy
- > Model H with replaceable HNBR pads for gentle handling
- > Model SI with replaceable silicone pads for gentle handling at high temperatures
- > Index 1N and 1P for direct sensor monitoring
- > Index 2N and 2P for teachable sensors, direct/indirect sensor monitoring
- > Index 3P for indirect sensor monitoring
- > PNP Inverter 20.530 enables direct control of parts on gripper GR04.090-3N: Sensor triggers as soon as part is gripped
- > The converter 20.531 enables the use of grippers in NPN circuits
- > Single-acting
- > Medium: filtered and oiled/non-oiled air
- > Ambient air temperature: -20°C to +80°C (-4 °F to 176 °F)
- > Ambient air temperature for sprue grippers with sensor: -20°C to +75°C (-4 °F to 167 °F)

### Technical data

Item no.	Jaw	Operating pressure [bar (psi)]	Sensor	Electric connection	Cable length [mm]	Closing force at 6 bar (87 psi) [N]	Weight [g]	Accessories
<b>GR04.090</b>	Standard	2.5 - 6 (36.3 - 87)	without	--	--	15	14	--
<b>GR04.090H</b>	HNBR Pad	2.5 - 6 (36.3 - 87)	without	--	--	15	15	HNBR pad: GR04.090-4
<b>GR04.090SI</b>	Silicone pad	2.5 - 6 (36.3 - 87)	without	--	--	15	15	Silicone pad: GR04.090-4SI
<b>GR04.090-1N</b>	Standard	2.5 - 6 (36.3 - 87)	NPN, direct monitoring, one freely adjustable switching point	3-pin male M8 connector	300	15	16	Connecting cable: 20.503
<b>GR04.090-1P</b>	Standard	2.5 - 6 (36.3 - 87)	PNP, direct monitoring, one freely adjustable switching point	3-pin male M8 connector	300	15	16	Connecting cable: 20.503
<b>GR04.090-3P</b>	Standard	2.5 - 6 (36.3 - 87)	PNP, indirect monitoring	3-pin male M8 connector	300	15	14	Connecting cable: 20.503
<b>GR04.090H-2N</b>	HNBR Pad	2.5 - 6 (36.3 - 87)	NPN, direct/indirect monitoring, two freely adjustable switching points teachable	4-pin male M8 connector	500	15	17	Connecting cable: 20.501 Connecting cable: 20.502 HNBR pad: GR04.090-4
<b>GR04.090H-2P</b>	HNBR Pad	2.5 - 6 (36.3 - 87)	PNP, direct/indirect monitoring, two freely adjustable switching points teachable	4-pin male M8 connector	500	15	17	Connecting cable: 20.501 Connecting cable: 20.502 HNBR pad: GR04.090-4
<b>GR04.090SI-2N</b>	Silicone pad	2.5 - 6 (36.3 - 87)	NPN, direct/indirect monitoring, two freely adjustable switching points teachable	4-pin male M8 connector	500	15	17	Connecting cable: 20.501 Connecting cable: 20.502 Silicone pad: GR04.090-4SI
<b>GR04.090SI-2P</b>	Silicone pad	2.5 - 6 (36.3 - 87)	PNP, direct/indirect monitoring, two freely adjustable switching points teachable	4-pin male M8 connector	500	15	17	Connecting cable: 20.501 Connecting cable: 20.502 Silicone pad: GR04.090-4SI



Dimensions

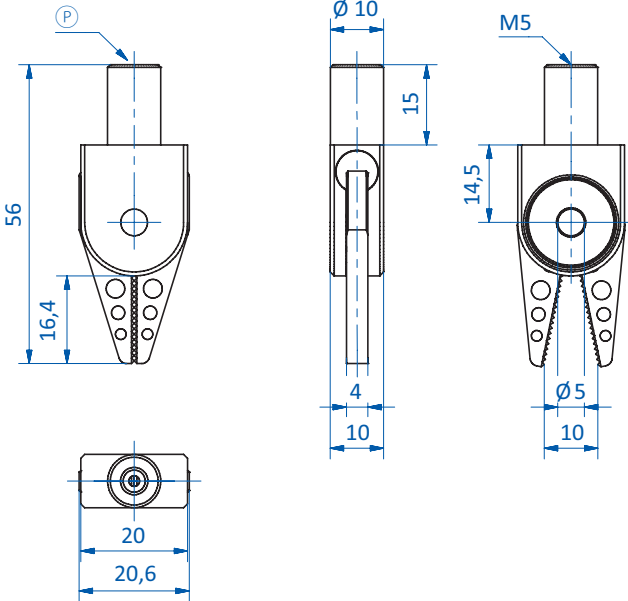

GR04.090

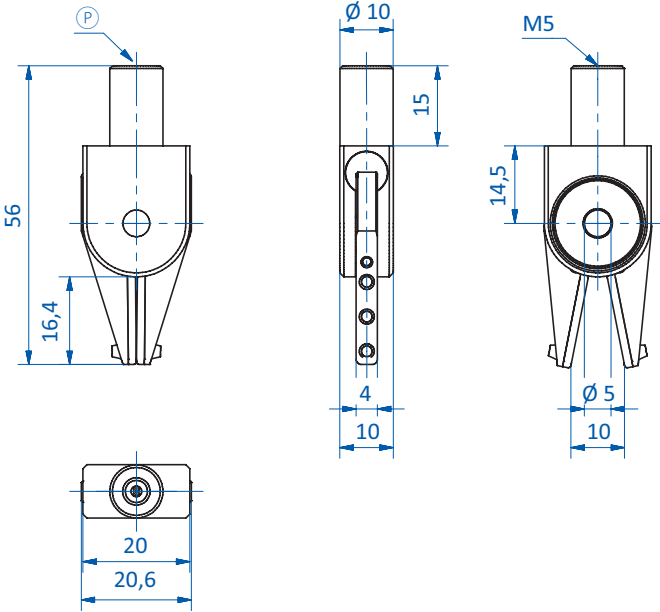

GR04.090H | GR04.090SI

Ⓟ = Compressed air connection

Continued on the next page →



# Grippers | Sprue grippers

Series 90 – miniature sprue grippers, clamping diameter 10 mm – single-acting

## Dimensions

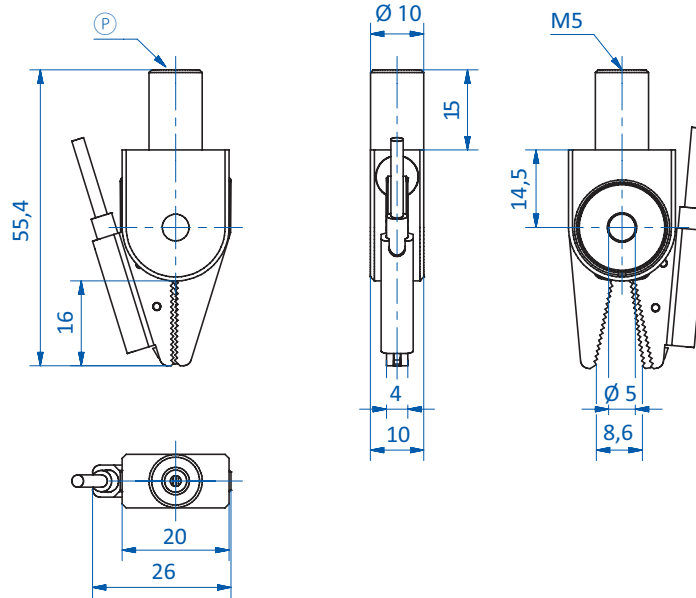

GR04.090-1N | GR04.090-1P

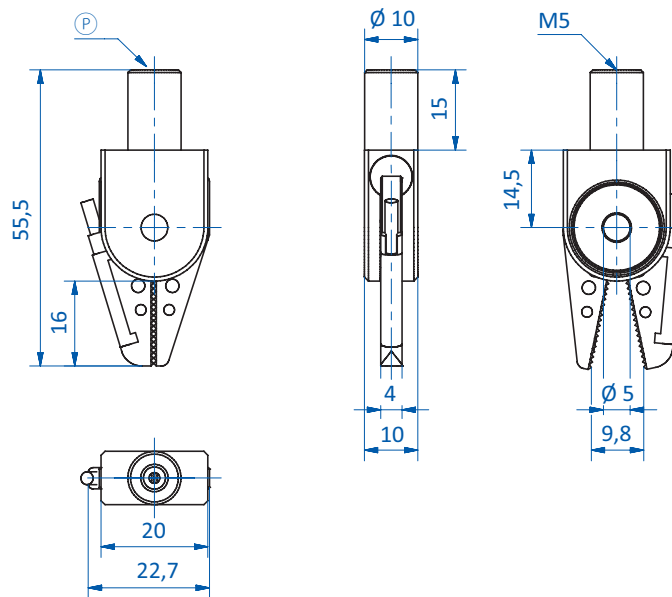

GR04.090-3P

Ⓟ = Compressed air connection



## Dimensions

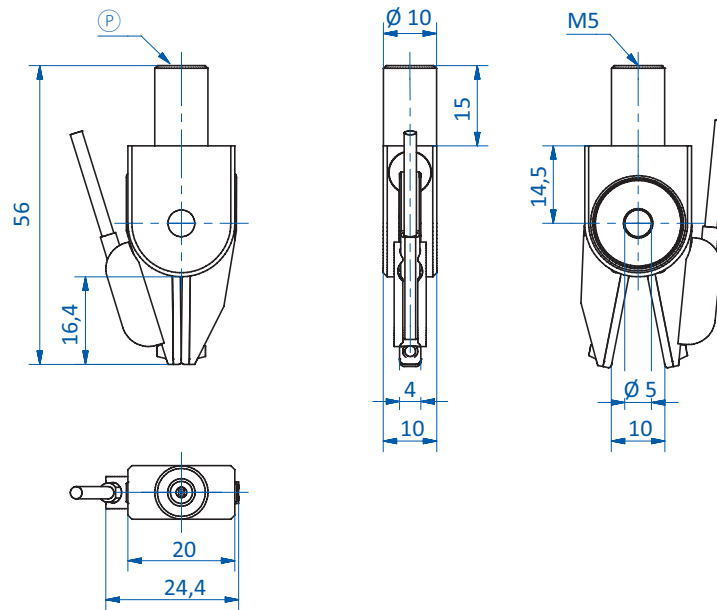

GR04.090H-2N | GR04.090H-2P | GR04.090SI-2N | GR04.090SI-2P

Ⓟ = Compressed air connection



# Grippers | Sprue grippers

Series 100 – sprue grippers, clamping diameter 10 mm – single-acting

## Series 100 – sprue grippers, clamping diameter 10 mm – single-acting



### Product notes

- > Grippers with wide jaw opening for large gates
- > Gap-free closing for flat gates
- > Housings and gripper jaws consist of an anodized, high-strength aluminum alloy (except GR04.100XW)
- > Model P with parrot beak for tightly seated sprues or undercuts
- > Model R with rotating gripper jaws for conical sprues
- > Model XW with extra wide steel jaws
- > Model B with rounded gripper jaws for large/inclined gates
- > Model U for special gripper jaws; the closing force depends on the shape of the gripper jaws
- > Model S with sawtooth profile for higher grip force
- > Model H with replaceable HNBR pads for gentle handling
- > Model XW with extra wide gripper jaws
- > Index 1N and 1P for direct monitoring; large-area sensor operation, regardless of the position of the gate in the gripper
- > Index 2N and 2P for teachable sensors, direct/indirect sensor monitoring
- > Index 3N and 3P for indirect monitoring; signal triggering if no component has been gripped; no moving parts and thus increased mechanical stability
- > Single-acting
- > Medium: filtered and oiled/non-oiled air
- > Ambient air temperature: -20°C to +80°C (-4 °F to 176 °F)
- > Ambient air temperature for sprue grippers with sensor: -20°C to +75°C (-4 °F to 167 °F)

### Technical data

Item no.	Jaw	Operating pressure [bar (psi)]	Sensor	Electric connection	Cable length [mm]	Closing force at 6 bar (87 psi) [N]	Weight [g]	Accessories
<b>GR04.100</b>	Standard	2.5 - 8 (36.3 - 116)	without	--	--	22	49	--
<b>GR04.100-1N</b>	Standard	2.5 - 8 (36.3 - 116)	NPN, direct monitoring, one freely adjustable switching point	3-pin male M8 connector	200	22	52	Connecting cable: 20.503
<b>GR04.100-1P</b>	Standard	2.5 - 8 (36.3 - 116)	PNP, direct monitoring, one freely adjustable switching point	3-pin male M8 connector	200	22	52	Connecting cable: 20.503
<b>GR04.100-2N</b>	Standard	2.5 - 8 (36.3 - 116)	NPN, direct/indirect monitoring, two freely adjustable switching points teachable	4-pin male M8 connector	500	22	53	Connecting cable: 20.501 Connecting cable: 20.502
<b>GR04.100-2P</b>	Standard	2.5 - 8 (36.3 - 116)	PNP, direct/indirect monitoring, two freely adjustable switching points teachable	4-pin male M8 connector	500	22	53	Connecting cable: 20.501 Connecting cable: 20.502
<b>GR04.100-3N</b>	Standard	2.5 - 8 (36.3 - 116)	NPN, indirect monitoring	3-pin male M8 connector	150	22	50	Connecting cable: 20.503
<b>GR04.100-3P</b>	Standard	2.5 - 8 (36.3 - 116)	PNP, indirect monitoring	3-pin male M8 connector	150	22	50	Connecting cable: 20.503
<b>GR04.100R</b>	Standard rotatable	2.5 - 8 (36.3 - 116)	without	--	--	22	85	--
<b>GR04.100S</b>	Sawtooth jaws straight	2.5 - 8 (36.3 - 116)	without	--	--	22	49	--





## Technical data

Item no.	Jaw	Operating pressure [bar (psi)]	Sensor	Electric connection	Cable length [mm]	Closing force at 6 bar (87 psi) [N]	Weight [g]	Accessories
<b>GR04.100S-1N</b>	Sawtooth jaws straight	2.5 - 8 (36.3 - 116)	NPN, direct monitoring, one freely adjustable switching point	3-pin male M8 connector	200	22	52	Connecting cable: 20.503
<b>GR04.100S-1P</b>	Sawtooth jaws straight	2.5 - 8 (36.3 - 116)	PNP, direct monitoring, one freely adjustable switching point	3-pin male M8 connector	200	22	52	Connecting cable: 20.503
<b>GR04.100U</b>	Universal	2.5 - 8 (36.3 - 116)	without	--	--	22	44	Exchangeable jaws: GR04.103-1 Exchangeable jaws: GR04.103-2 Exchangeable jaws: GR04.103-3 Exchangeable jaws: GR04.103-4
<b>GR04.100H</b>	HNBR Pad	2.5 - 8 (36.3 - 116)	without	--	--	22	46	HNBR pad: GR04.103-4 HNBR
<b>GR04.100H-2N</b>	HNBR Pad	2.5 - 8 (36.3 - 116)	NPN, direct/indirect monitoring, two freely adjustable switching points teachable	4-pin male M8 connector	500	22	50	Connecting cable: 20.501 Connecting cable: 20.502 HNBR pad: GR04.103-4 HNBR
<b>GR04.100H-2P</b>	HNBR Pad	2.5 - 8 (36.3 - 116)	PNP, direct/indirect monitoring, two freely adjustable switching points teachable	4-pin male M8 connector	500	22	50	Connecting cable: 20.501 Connecting cable: 20.502 HNBR pad: GR04.103-4 HNBR
<b>GR04.100HNBR</b>	Fully HNBR-coated	2.5 - 8 (36.3 - 116)	without	--	--	22	48	--
<b>GR04.100B</b>	Sawtooth jaws round	2.5 - 8 (36.3 - 116)	without	--	--	22	49	--
<b>GR04.100P</b>	Parrot	2.5 - 8 (36.3 - 116)	without	--	--	22	49	--
<b>GR04.100P-1N</b>	Parrot	2.5 - 8 (36.3 - 116)	NPN, direct monitoring, one freely adjustable switching point	3-pin male M8 connector	200	22	61	Connecting cable: 20.503
<b>GR04.100P-1P</b>	Parrot	2.5 - 8 (36.3 - 116)	PNP, direct monitoring, one freely adjustable switching point	3-pin male M8 connector	200	22	61	Connecting cable: 20.503
<b>GR04.100XW</b>	Xwide	2.5 - 8 (36.3 - 116)	without	--	--	22	85	--

Continued on the next page →



# Grippers | Sprue grippers

Series 100 – sprue grippers, clamping diameter 10 mm – single-acting

## Dimensions

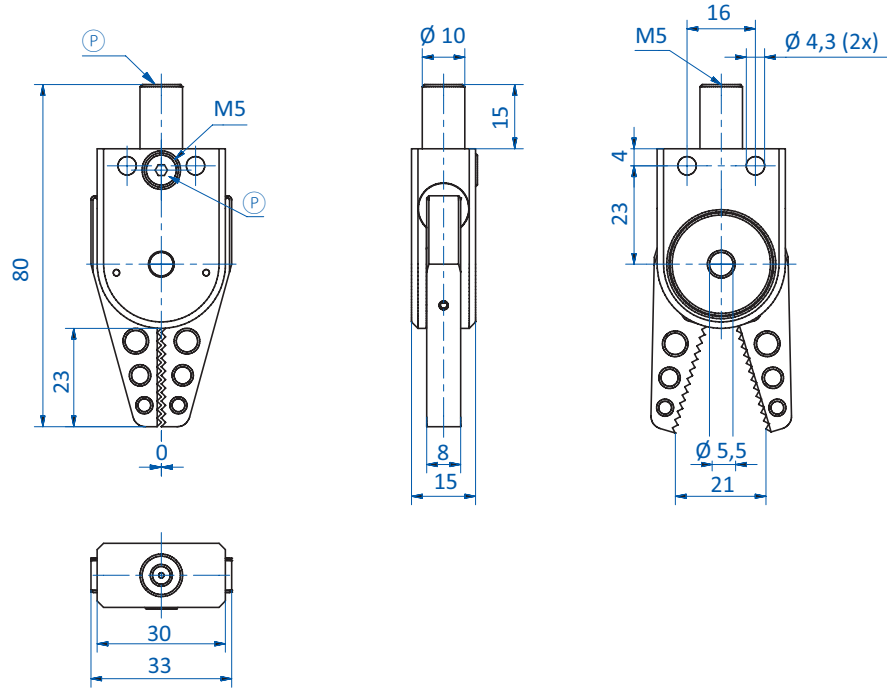

GR04.100

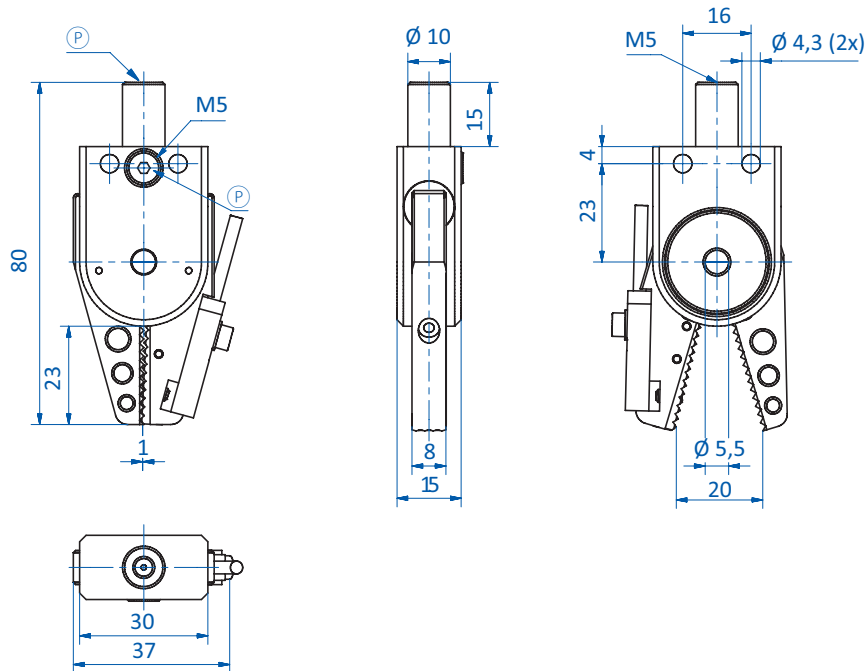

GR04.100-1N | GR04.100-1P

Ⓟ = Compressed air connection



Dimensions

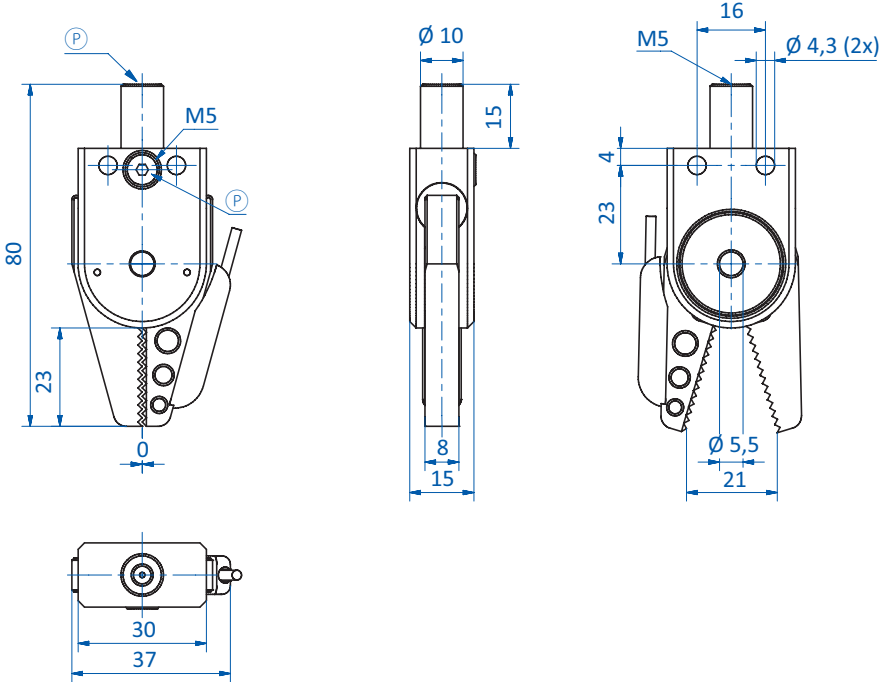

GR04.100-2N | GR04.100-2P

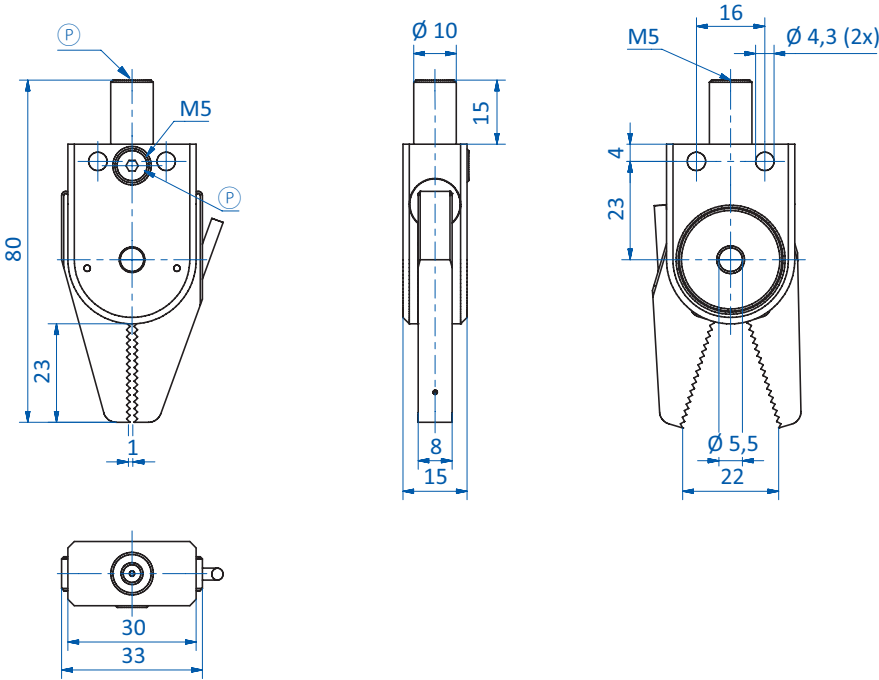

GR04.100-3N | GR04.100-3P

Ⓟ = Compressed air connection

Continued on the next page →



# Grippers | Sprue grippers

Series 100 – sprue grippers, clamping diameter 10 mm – single-acting

## Dimensions

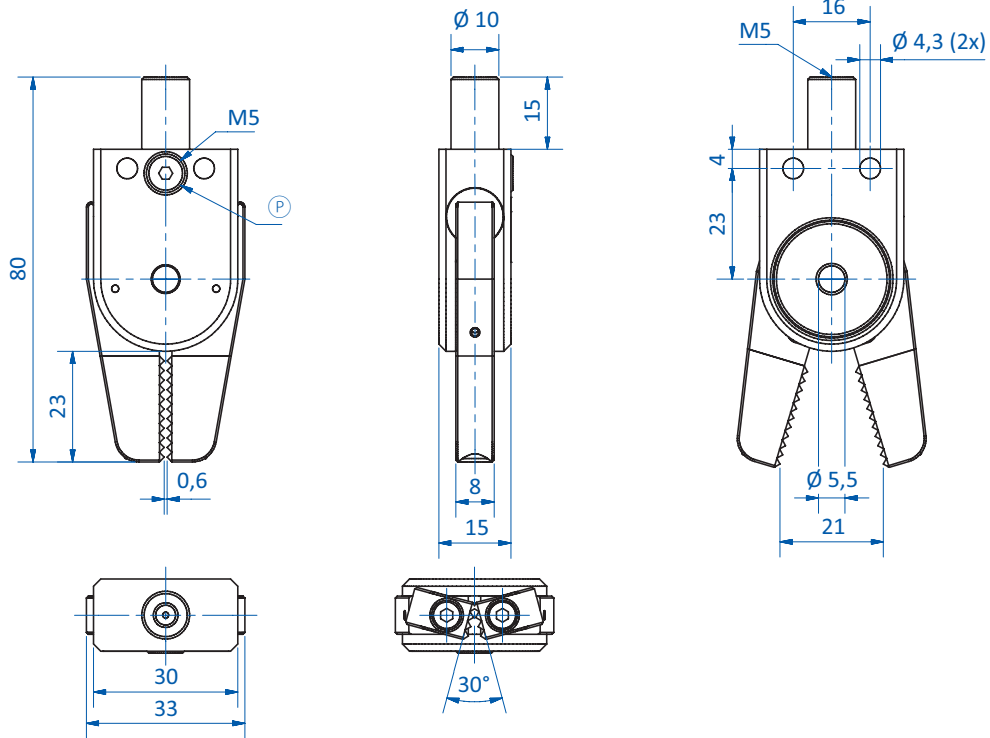

GR04.100R

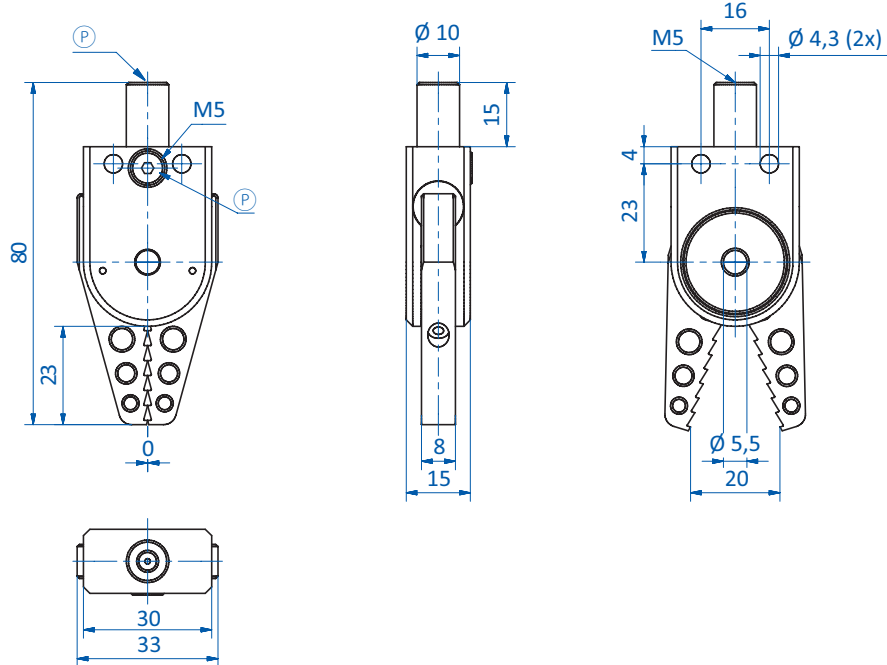

GR04.100S

Ⓟ = Compressed air connection



## Dimensions

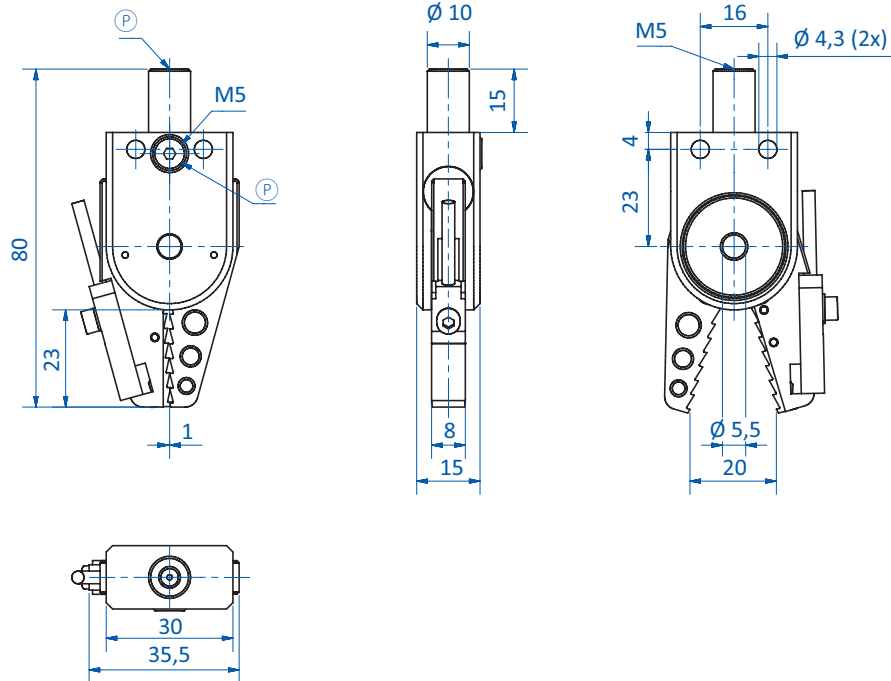

GR04.100S-1N | GR04.100S-1P

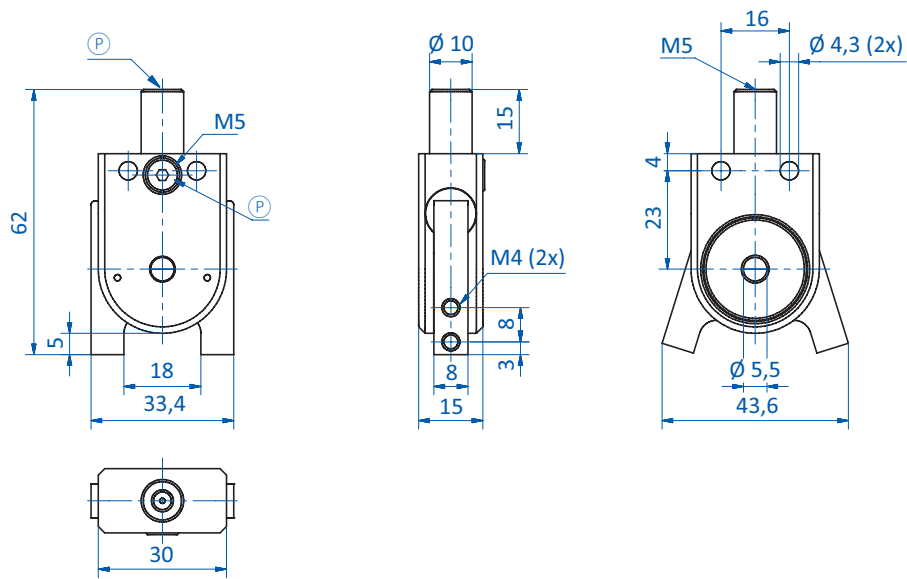

GR04.100U

Ⓟ = Compressed air connection

Continued on the next page →



# Grippers | Sprue grippers

Series 100 – sprue grippers, clamping diameter 10 mm – single-acting

## Dimensions

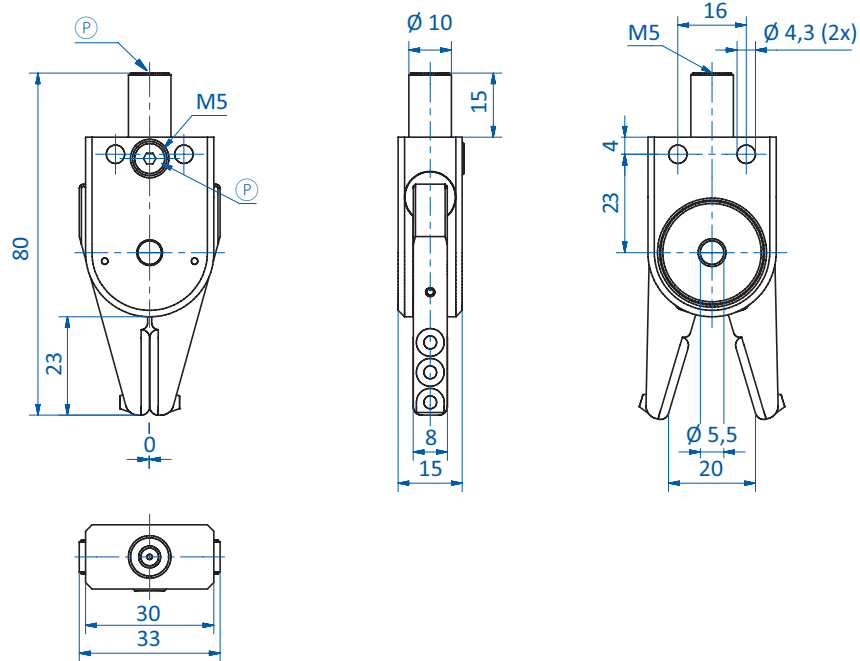

GR04.100H

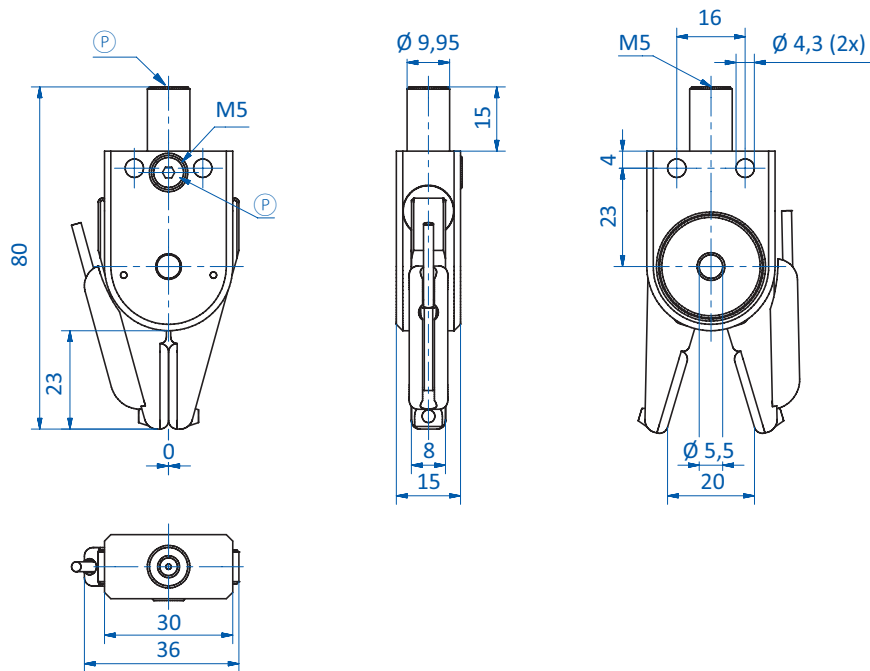

GR04.100H-2N | GR04.100H-2P

Ⓟ = Compressed air connection



Dimensions

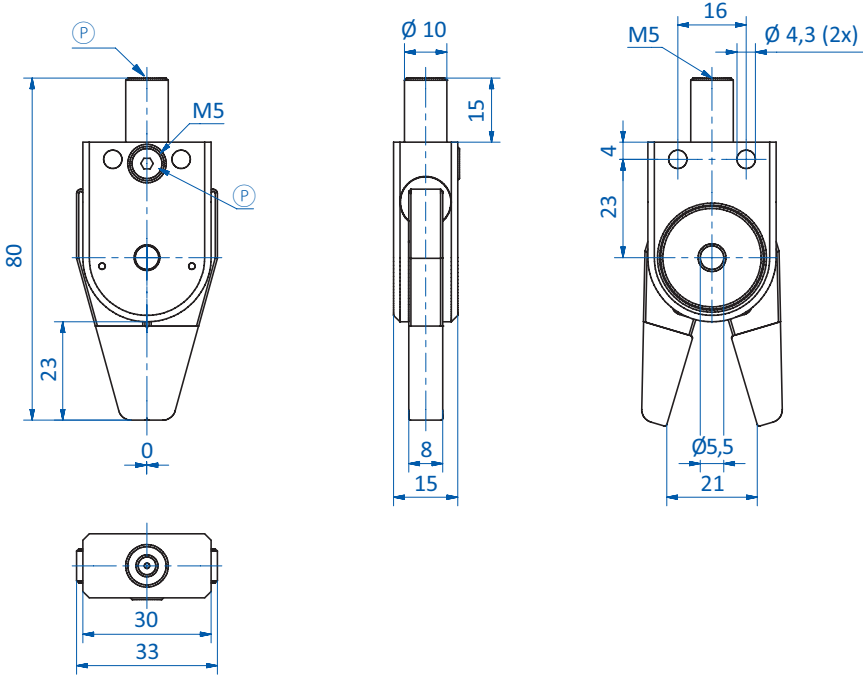

GR04.100HNBR

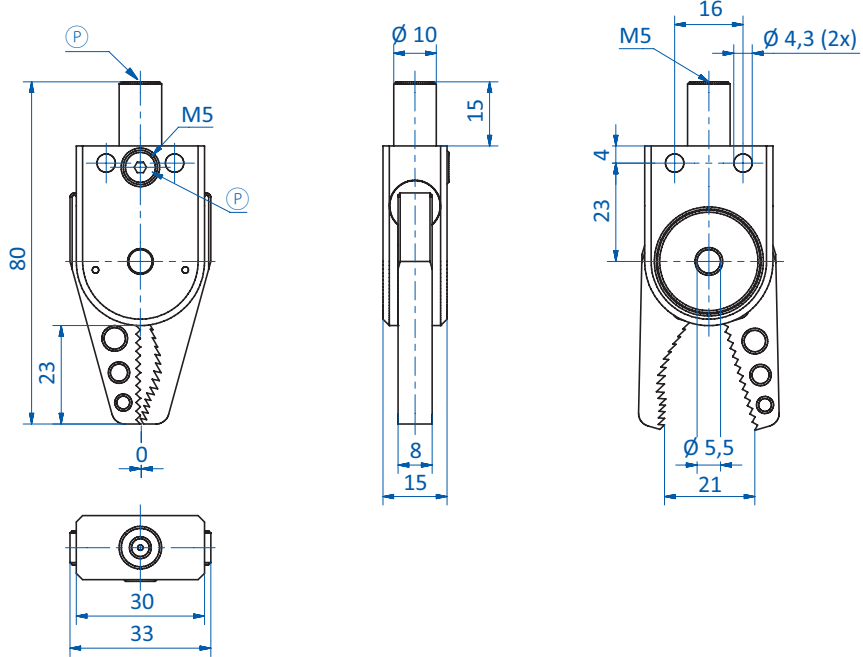

GR04.100B

Ⓟ = Compressed air connection

Continued on the next page →



# Grippers | Sprue grippers

Series 100 – sprue grippers, clamping diameter 10 mm – single-acting

## Dimensions

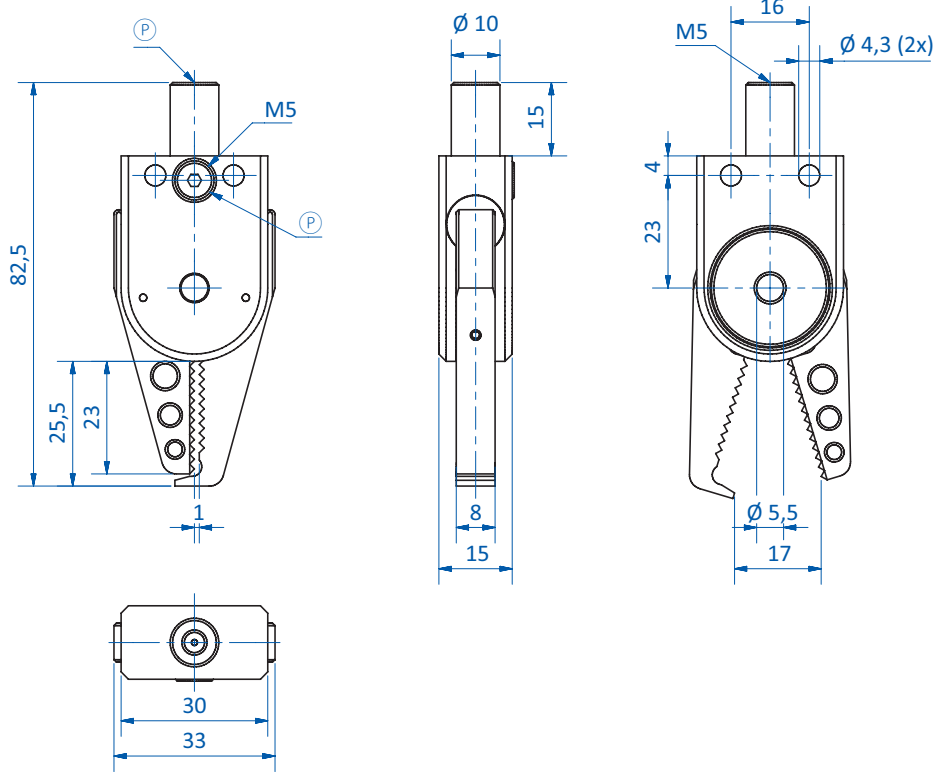

GR04.100P

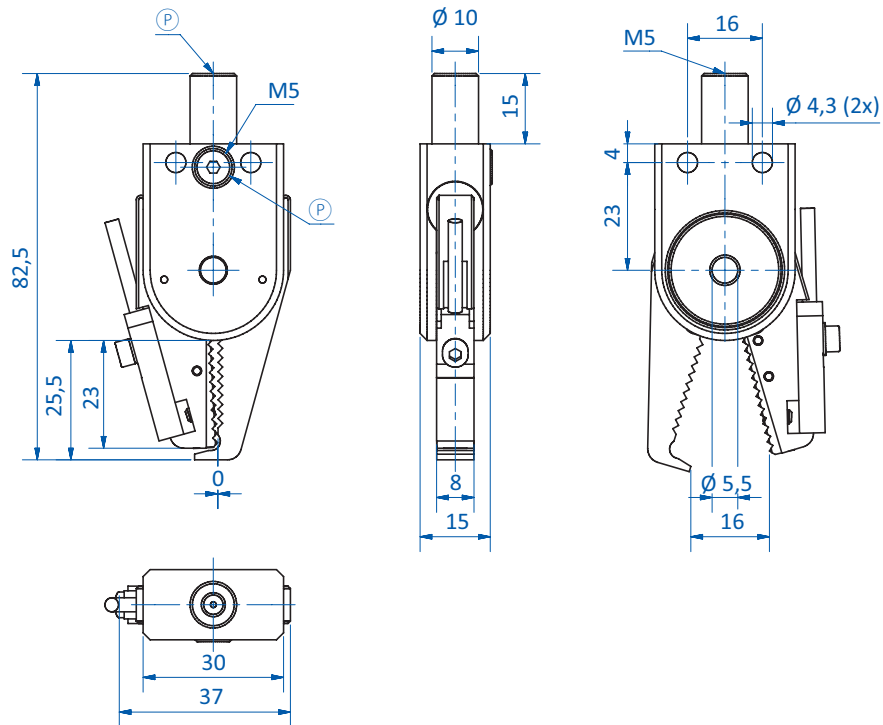

GR04.100P-1N | GR04.100P-1P

Ⓟ = Compressed air connection





Dimensions

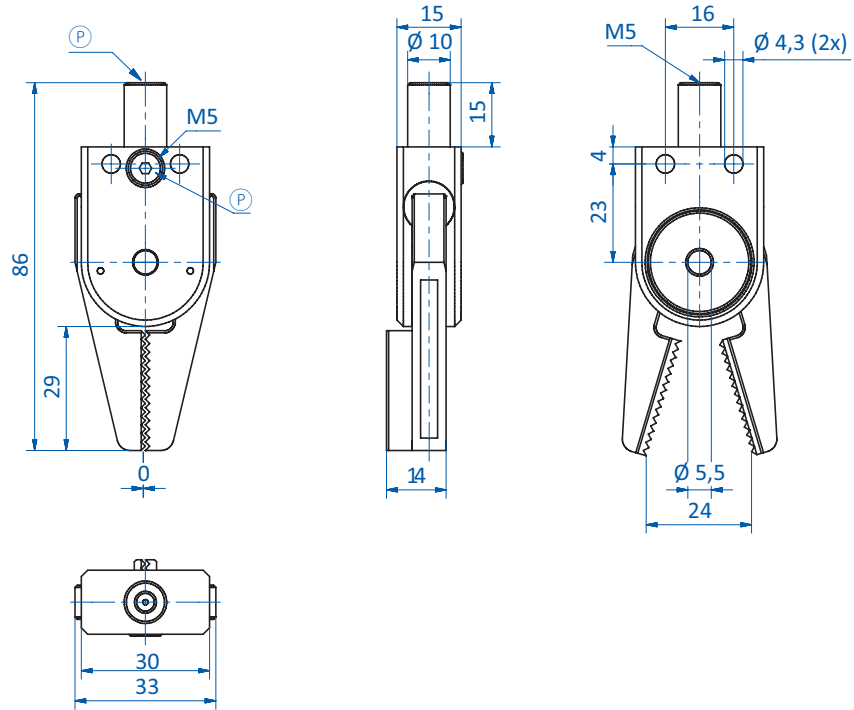

GR04.100XW

Ⓟ = Compressed air connection



# Grippers | Sprue grippers

Series 100 – sprue grippers, clamping diameter 10 mm – double-acting

## Series 100 – sprue grippers, clamping diameter 10 mm – double-acting



### Product notes

- > Grippers with wide jaw opening for large gates
- > Gap-free closing for flat gates
- > Dual-action for short cycle times; opening and closing separately controllable
- > Housings and gripper jaws consist of an anodized, high-strength aluminum alloy
- > Spring-assisted opening
- > Double-acting
- > Medium: filtered and oiled/non-oiled air
- > Ambient air temperature: -20°C to +80°C (-4 °F to 176 °F)

### Technical data

Item no.	Jaw	Operating pressure [bar (psi)]	Sensor	Closing force at 6 bar (87 psi) [N]	Weight [g]
<b>GR04.102</b>	Standard	2.5 - 8 (36.3 - 116)	without	20	51

### Dimensions

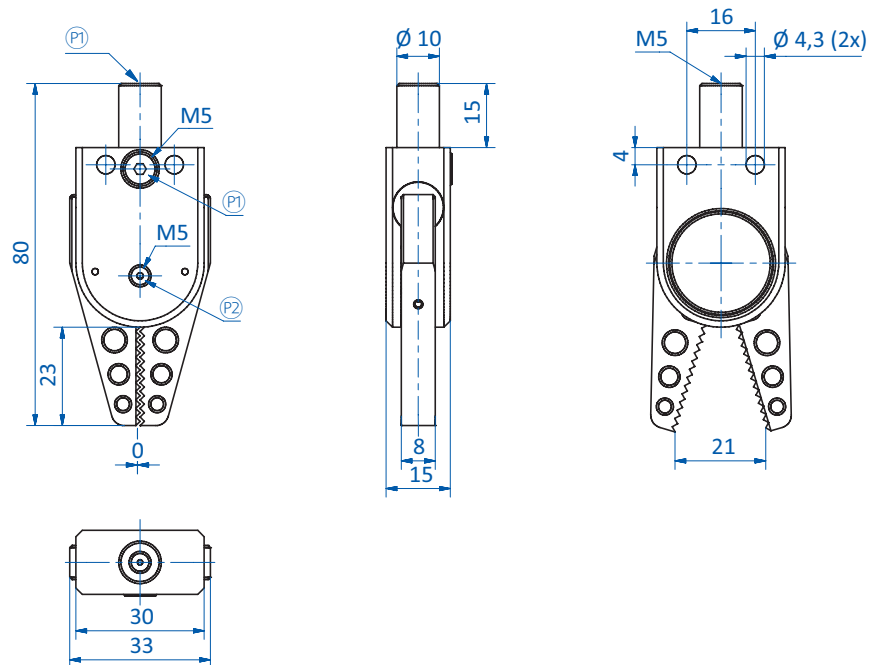

Ⓟ = Compressed air supply (close) Ⓠ = Compressed air supply (open)



Interchangeable jaws for gripper GR04.100U

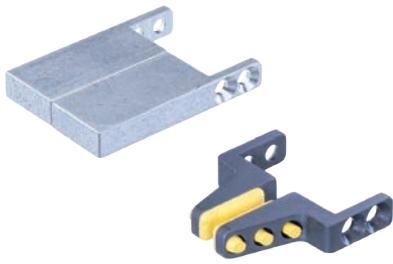

GR04.103-1 and GR04.103-4



GR04.103-2 and GR04.103-3

Product notes

> Interchangeable jaws for gripper GR04.100U

Technical data

Item no.	Jaw design	Application benefit	Weight [g]	Replacement parts
GR04.103-1	Blank jaws	Aluminum-blanks: For customized jaw design	40	--
GR04.103-2	V-shape	Enables axial gripping of sprues	14	--
GR04.103-3	V-shape, prism shape	Enables three point contact when gripping conical sprues	14	--
GR04.103-4	Jaws with HNBR pads	2 x jaws with HNBR pads – gentle gripping of sensitive components. Temperature range 0 - 160 °C (0 - 320 °F) for short term contact – up to 30 seconds	14	GR04.103-4 HNBR

Dimensions

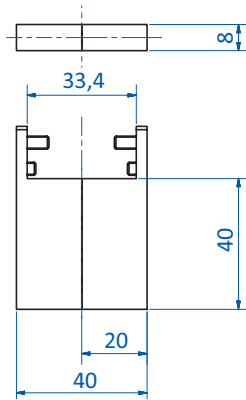

GR04.103-1

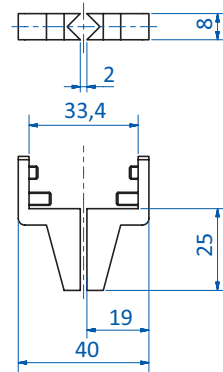

GR04.103-2

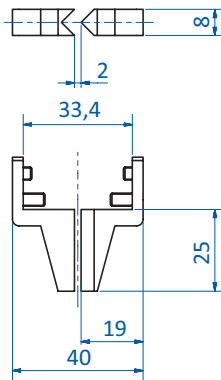

GR04.103-3

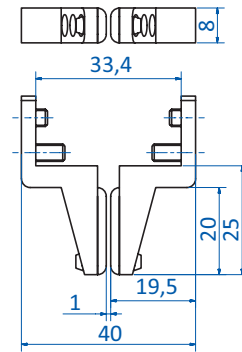

GR04.103-4



### Series 130 – sprue grippers, clamping diameter 20 mm – single-acting



#### Product notes

- > Grippers with strong gripping force and wide jaw opening for large gates
- > Tight closing for flat gates
- > Housings and gripper jaws consist of an anodized, high-strength aluminum alloy
- > Model 130 with straight gripper jaws
- > Model 130S with sawtooth profile for inclined gates
- > Model 130U for special gripper jaws; the closing force depends on the shape of the gripper jaws
- > Model 130H with replaceable HNBR pads for gentle handling
- > Model 130B with rounded gripper jaws for large/inclined gates
- > Model P with parrot beak for tightly seated sprues or undercuts
- > Model 130SXL sawtooth profile with extra-long jaws for long sprues
- > Model 130XW with extra wide gripper jaws for fan gates
- > Index 1N and 1P for direct monitoring; large-area sensor operation, regardless of the position of the gate in the gripper
- > Index 2N and 2P for teachable sensors, direct/indirect sensor monitoring
- > Index 3N and 3P for indirect monitoring; signal triggering if no component has been gripped; no moving parts and thus increased mechanical stability
- > Single-acting
- > Medium: filtered and oiled/non-oiled air
- > Ambient air temperature: -20°C to +80°C (-4 °F to 176 °F)
- > Ambient air temperature for sprue grippers with sensor: -20°C to +75°C (-4 °F to 167 °F)

#### Technical data

Item no.	Jaw	Operating pressure [bar (psi)]	Sensor	Electric connection	Cable length [mm]	Closing force at 6 bar (87 psi) [N]	Weight [g]	Accessories
<b>GR04.130</b>	Standard	2.5 - 8 (36.3 - 116)	without	--	--	95	133	Extension tube: GR06.024
<b>GR04.130-1N</b>	Standard	2.5 - 8 (36.3 - 116)	NPN, direct monitoring, one freely adjustable switching point	3-pin male M8 connector	200	95	141	Extension tube: GR06.024 Connecting cable: 20.503
<b>GR04.130-1P</b>	Standard	2.5 - 8 (36.3 - 116)	PNP, direct monitoring, one freely adjustable switching point	3-pin male M8 connector	200	95	141	Extension tube: GR06.024 Connecting cable: 20.503
<b>GR04.130S</b>	Sawtooth jaws straight	2.5 - 8 (36.3 - 116)	without	--	--	95	134	Extension tube: GR06.024
<b>GR04.130U</b>	Universal	2.5 - 8 (36.3 - 116)	without	--	--	--	128	Extension tube: GR06.024 Exchangeable jaws: GR04.130C-1 Exchangeable jaws: GR04.130C-4
<b>GR04.130H</b>	HNBR Pad	2.5 - 8 (36.3 - 116)	without	--	--	95	137	Extension tube: GR06.024 HNBR pad: GR04.130C-4 HNBR
<b>GR04.130H-2N</b>	HNBR Pad	2.5 - 8 (36.3 - 116)	NPN, direct/indirect monitoring, two freely adjustable switching points teachable	4-pin male M8 connector	500	95	139	Extension tube: GR06.024 Connecting cable: 20.501 HNBR pad: GR04.130C-4 HNBR



## Technical data

Item no.	Jaw	Operating pressure [bar (psi)]	Sensor	Electric connection	Cable length [mm]	Closing force at 6 bar (87 psi) [N]	Weight [g]	Accessories
<b>GR04.130H-2P</b>	HNBR Pad	2.5 - 8 (36.3 - 116)	PNP, direct/indirect monitoring, two freely adjustable switching points teachable	4-pin male M8 connector	500	95	139	Extension tube: GR06.024 Connecting cable: 20.501 HNBR pad: GR04.130C-4 HNBR
<b>GR04.130B</b>	Sawtooth jaws round	2.5 - 8 (36.3 - 116)	without	--	--	95	131	Extension tube: GR06.024
<b>GR04.130B-1N</b>	Sawtooth jaws round	2.5 - 8 (36.3 - 116)	NPN, direct monitoring, one freely adjustable switching point	3-pin male M8 connector	200	95	140	Extension tube: GR06.024 Connecting cable: 20.503
<b>GR04.130B-1P</b>	Sawtooth jaws round	2.5 - 8 (36.3 - 116)	PNP, direct monitoring, one freely adjustable switching point	3-pin male M8 connector	200	95	140	Extension tube: GR06.024 Connecting cable: 20.503
<b>GR04.130P</b>	Parrot	2.5 - 8 (36.3 - 116)	without	--	--	95	140	Extension tube: GR06.024
<b>GR04.130P-1N</b>	Parrot	2.5 - 8 (36.3 - 116)	NPN, direct monitoring, one freely adjustable switching point	3-pin male M8 connector	200	95	149	Extension tube: GR06.024 Connecting cable: 20.503
<b>GR04.130P-1P</b>	Parrot	2.5 - 8 (36.3 - 116)	PNP, direct monitoring, one freely adjustable switching point	3-pin male M8 connector	200	95	149	Extension tube: GR06.024 Connecting cable: 20.503
<b>GR04.130SXL</b>	Xlong	2.5 - 8 (36.3 - 116)	without	--	--	82	140	Extension tube: GR06.024
<b>GR04.130SXL-2N</b>	Xlong	2.5 - 8 (36.3 - 116)	NPN, direct/indirect monitoring, two freely adjustable switching points teachable	4-pin male M8 connector	500	82	155	Extension tube: GR06.024 Connecting cable: 20.501
<b>GR04.130SXL-2P</b>	Xlong	2.5 - 8 (36.3 - 116)	PNP, direct/indirect monitoring, two freely adjustable switching points teachable	4-pin male M8 connector	500	82	155	Extension tube: GR06.024 Connecting cable: 20.501
<b>GR04.130XW</b>	Xwide	2.5 - 8 (36.3 - 116)	without	--	--	95	148	Extension tube: GR06.024
<b>GR04.130XW-2N</b>	Xwide	2.5 - 8 (36.3 - 116)	NPN, direct/indirect monitoring, two freely adjustable switching points teachable	4-pin male M8 connector	500	95	151	Extension tube: GR06.024 Connecting cable: 20.501
<b>GR04.130XW-2P</b>	Xwide	2.5 - 8 (36.3 - 116)	PNP, direct/indirect monitoring, two freely adjustable switching points teachable	4-pin male M8 connector	500	95	151	Extension tube: GR06.024 Connecting cable: 20.501
<b>GR04.130XW-3P</b>	Xwide	2.5 - 8 (36.3 - 116)	PNP, indirect monitoring	3-pin male M8 connector	340	95	139	Extension tube: GR06.024 Connecting cable: 20.503

Continued on the next page →



# Grippers | Sprue grippers

Series 130 – sprue grippers, clamping diameter 20 mm – single-acting

## Dimensions

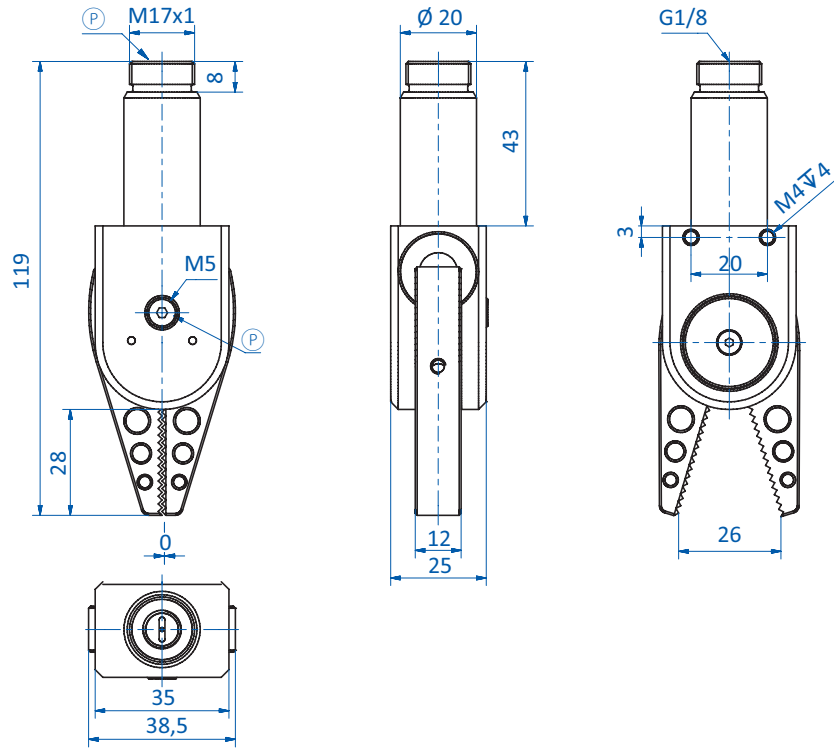

GR04.130

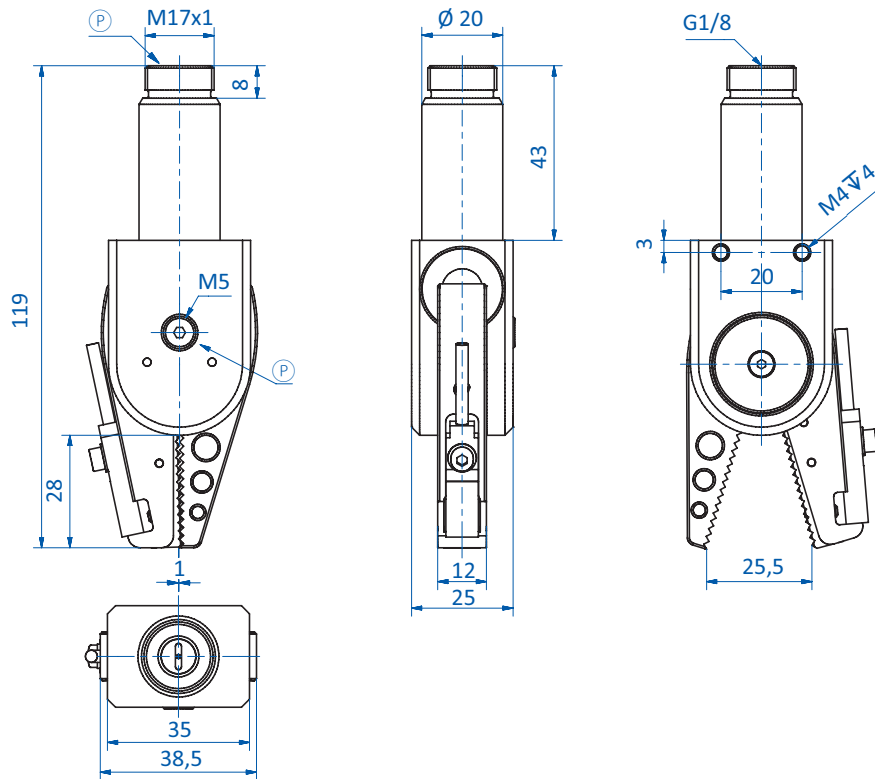

GR04.130-1N | GR04.130-1P

Ⓟ = Compressed air connection



Dimensions

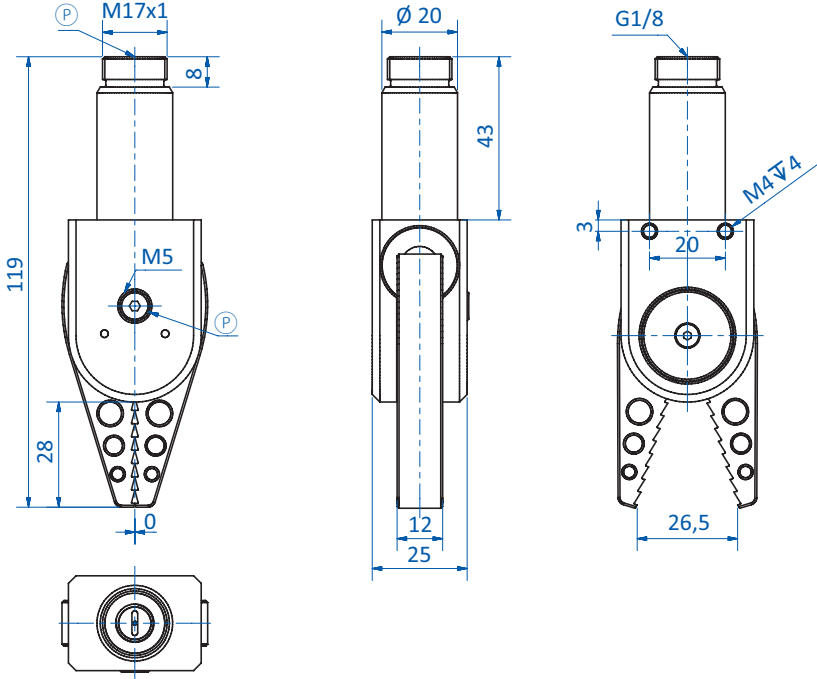

GR04.130S

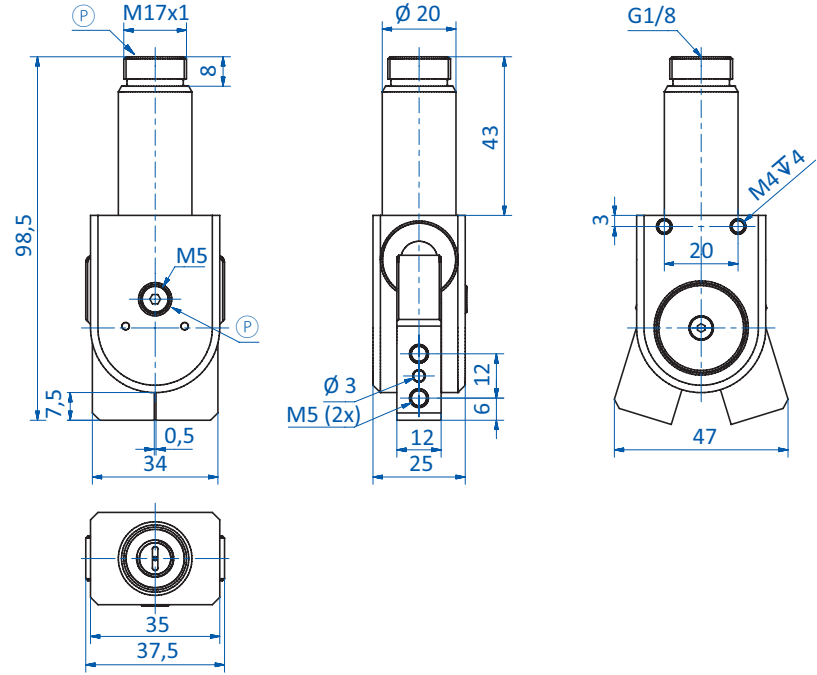

GR04.130U

Ⓟ = Compressed air connection

Continued on the next page →



# Grippers | Sprue grippers

Series 130 – sprue grippers, clamping diameter 20 mm – single-acting

## Dimensions

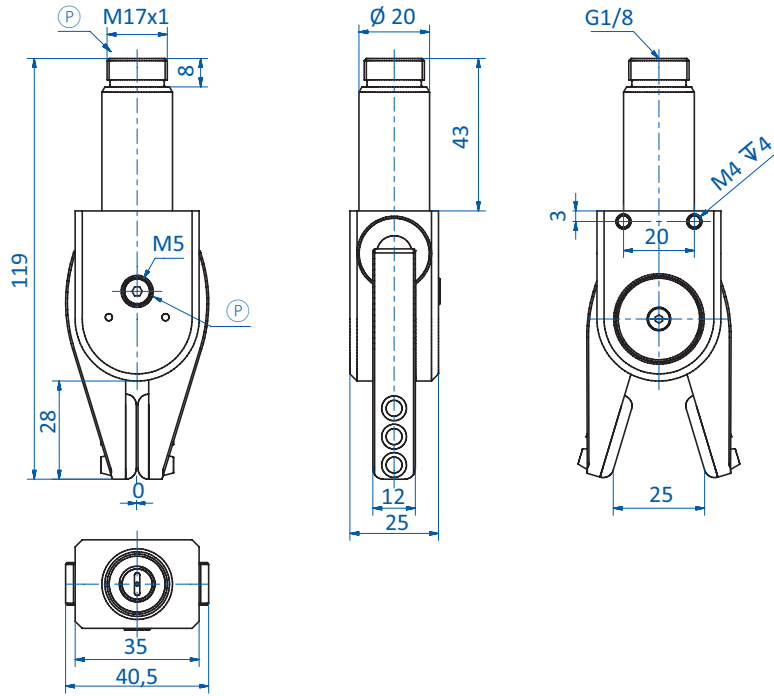

GR04.130H

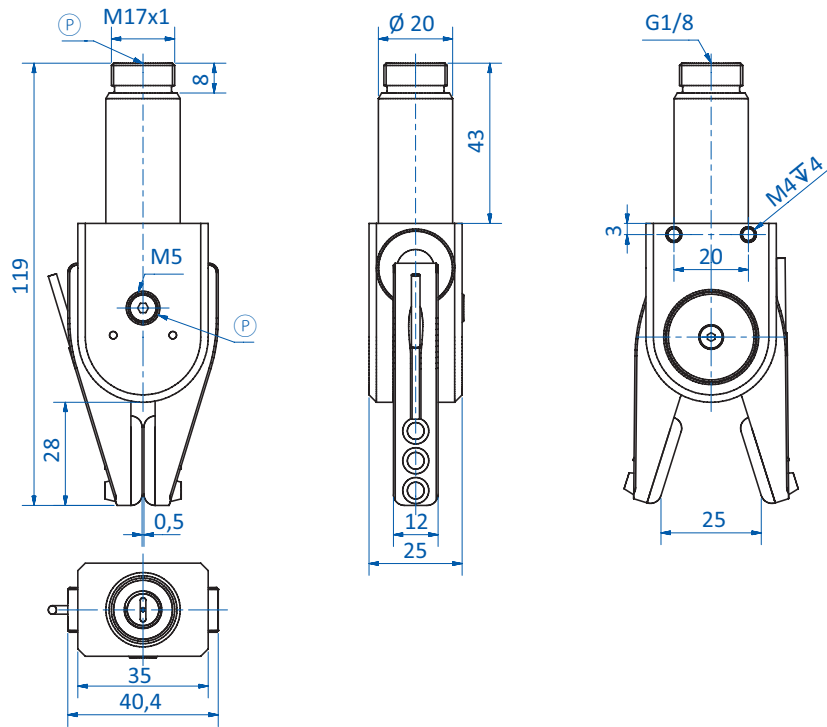

GR04.130H-2N | GR04.130H-2P

Ⓟ = Compressed air connection





Dimensions

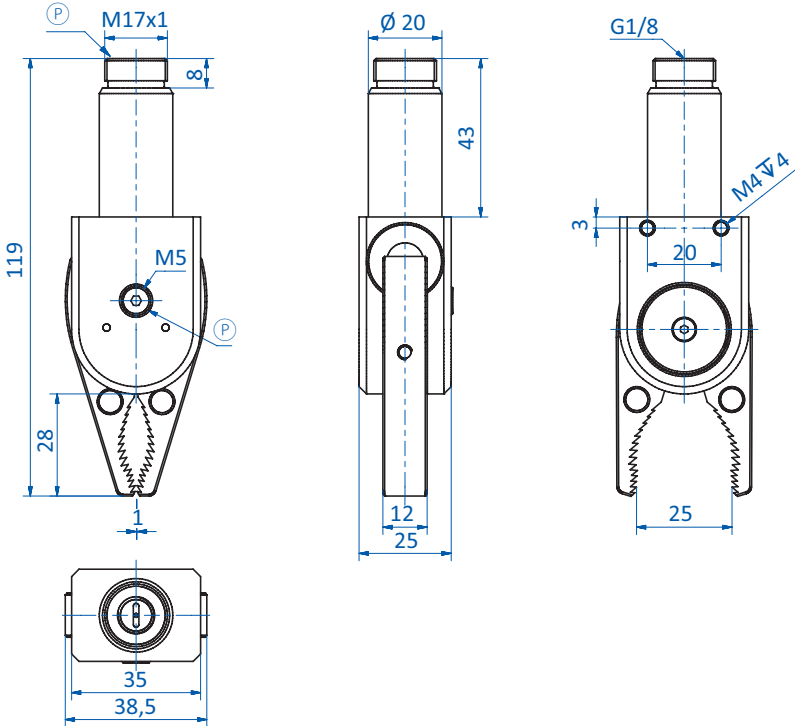

GR04.130B

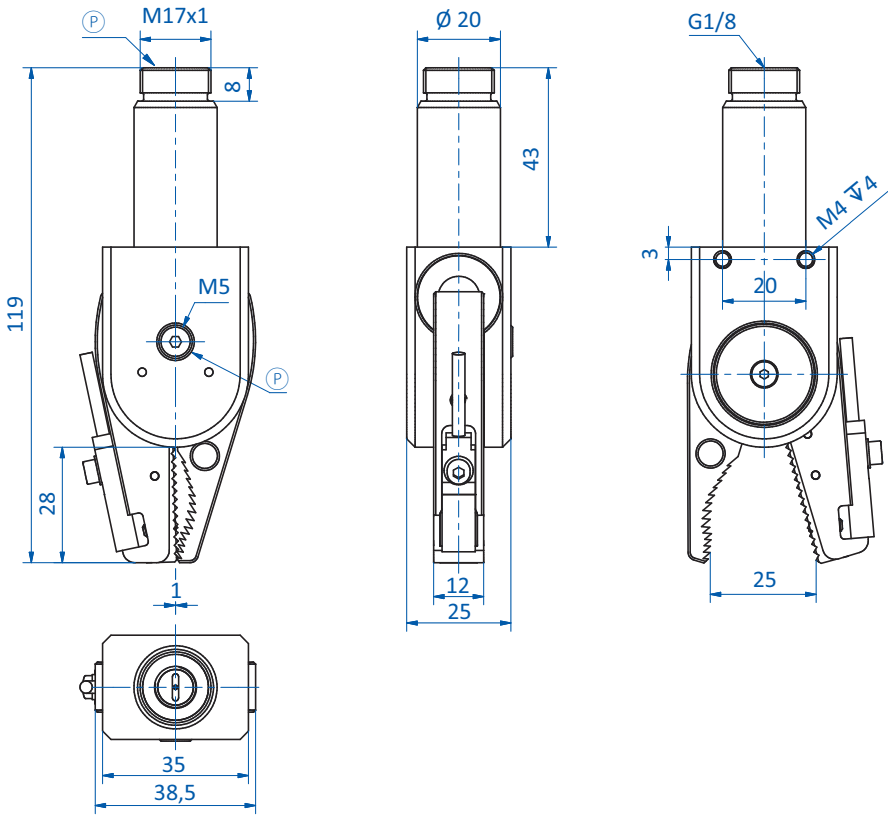

GR04.130B-1N | GR04.130B-1P

Ⓟ = Compressed air connection

Continued on the next page



# Grippers | Sprue grippers

Series 130 – sprue grippers, clamping diameter 20 mm – single-acting

## Dimensions

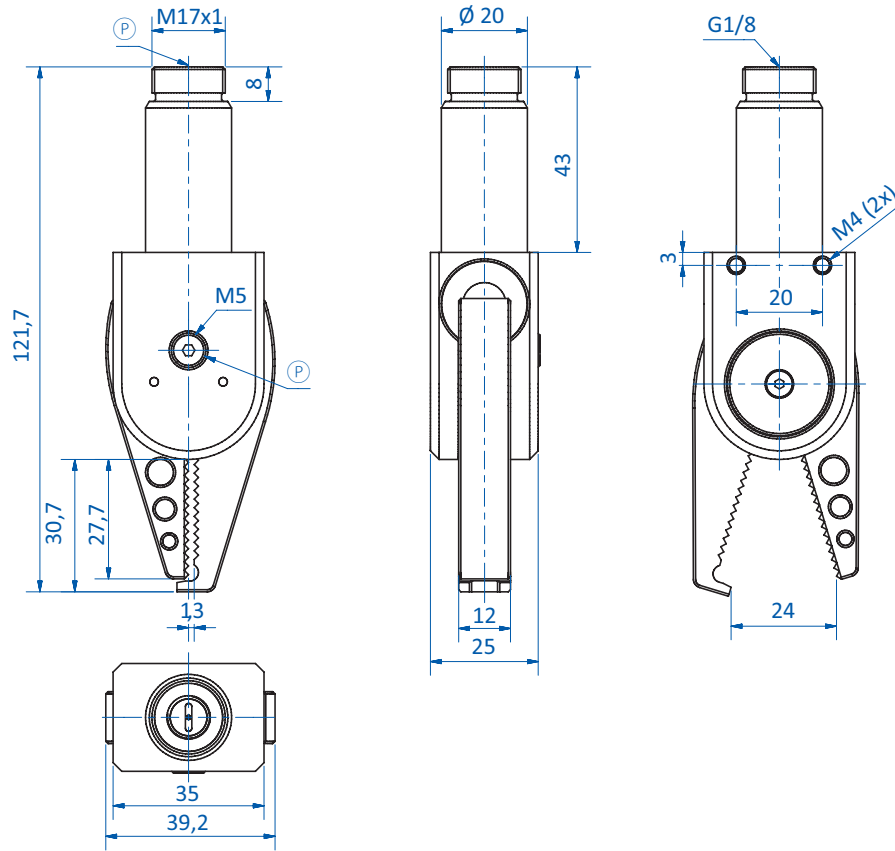

GR04.130P

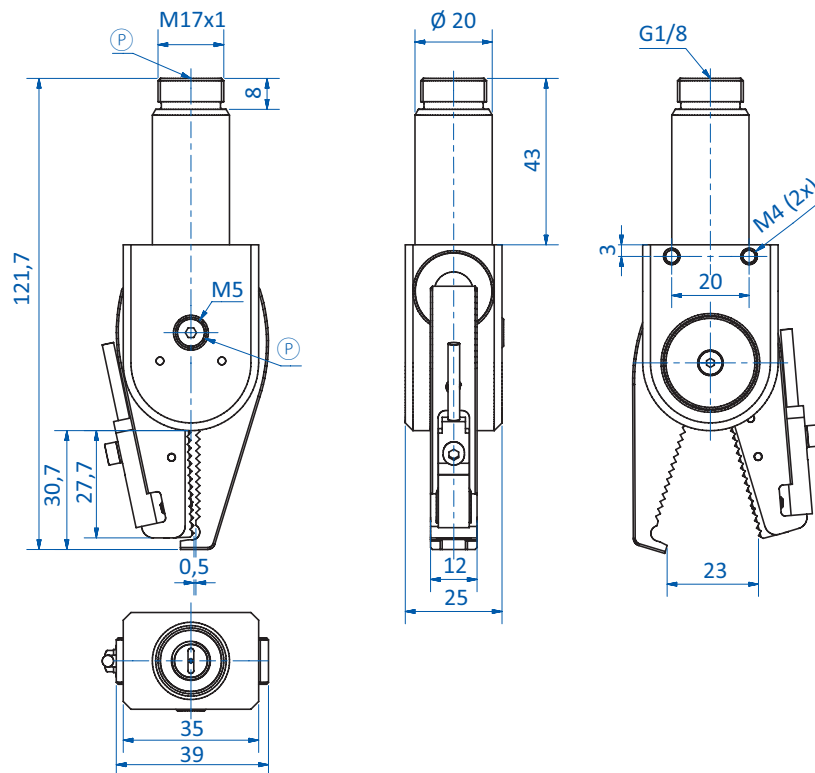

GR04.130P-1N | GR04.130P-1P

Ⓟ = Compressed air connection



Dimensions

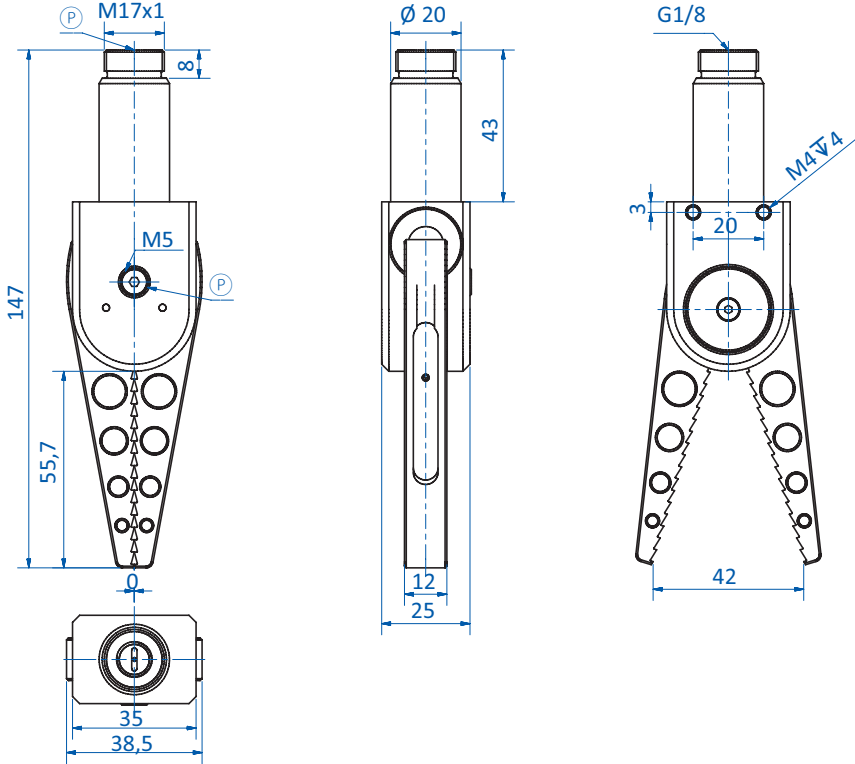

GR04.130SXL | GR04.130SXL-2N | GR04.130SXL-2P

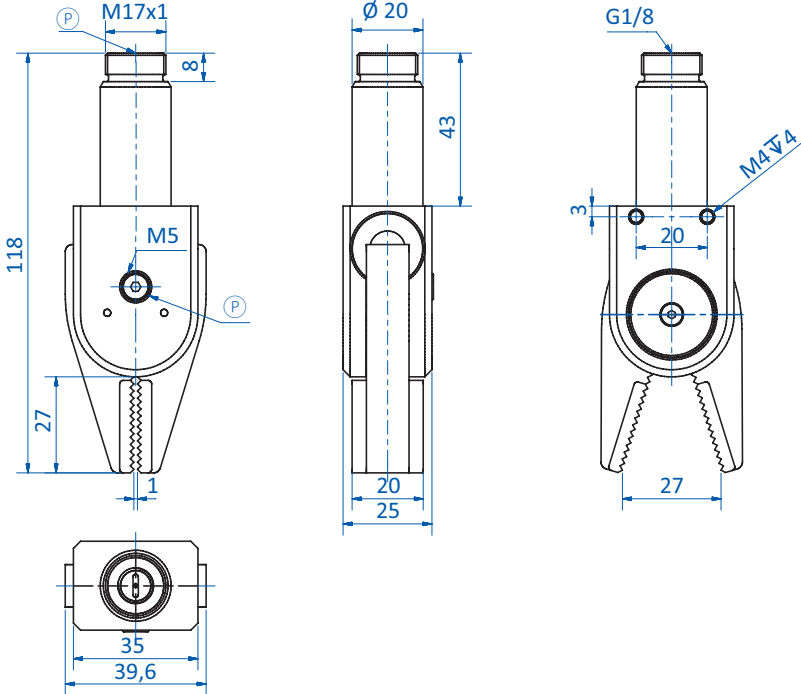

GR04.130XW | GR04.130XW-3P

Ⓟ = Compressed air connection

Continued on the next page →



# Grippers | Sprue grippers

Series 130 – sprue grippers, clamping diameter 20 mm – single-acting

## Dimensions

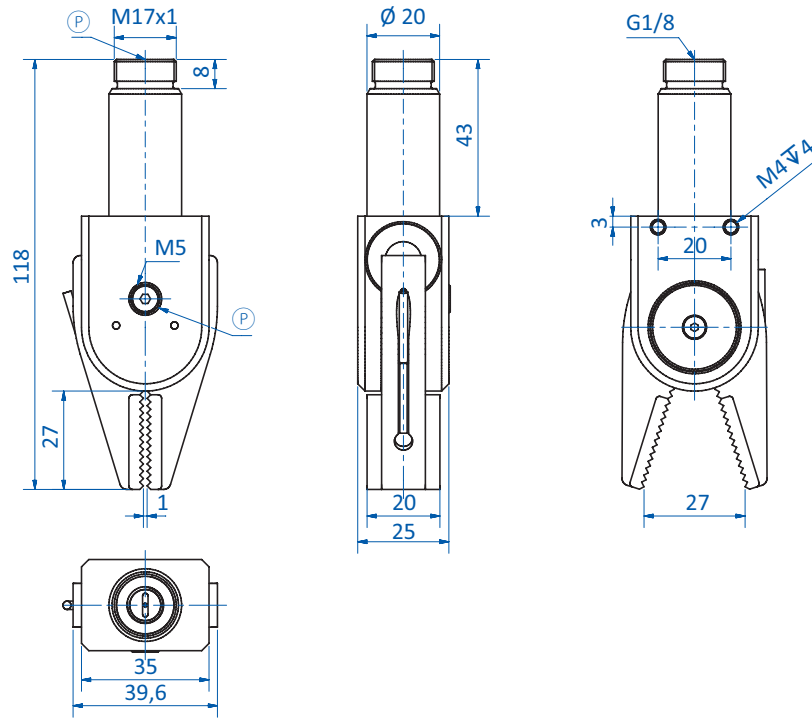

GR04.130XW-2N | GR04.130XW-2P

Ⓟ = Compressed air connection



Interchangeable jaws for gripper GR04.130U

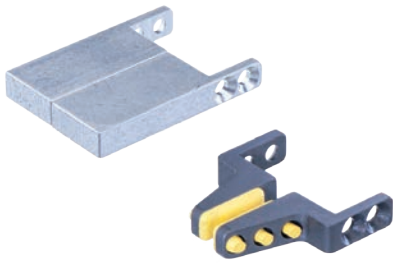

GR04.130C-1 and GR04.130C-4

\* = Closing force depends on geometry of gripper jaws

Product notes

> Interchangeable jaws for gripper GR04.130U

Technical data

Item no.	Jaw design	Application benefit	Weight [g]	Replacement parts
GR04.130C-1	Blank jaws	Aluminum-blanks: For customized jaw design	87	--
GR04.130C-4	Jaws with HNBR pads	2 x jaws with HNBR pads – gentle gripping of sensitive components. Temperature range 0 - 160 °C (0 - 320 °F) for short term contact – up to 30 seconds	35	GR04.130C-4 HNBR

Dimensions

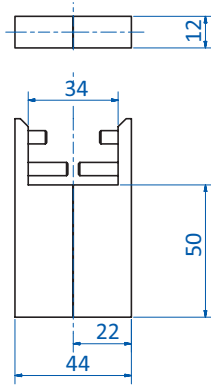

GR04.130C-1

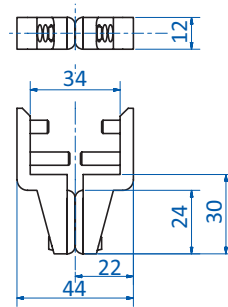

GR04.130C-4



# Grippers | Sprue grippers

Series 2016 – sprue grippers, clamping diameter 20 mm – single-acting

## Series 2016 – sprue grippers, clamping diameter 20 mm – single-acting

SELF-CENTERING



### Product notes

- > Grippers with wide opening jaws and high gripping force
- > Self-centering
- > Large area sensor activation, regardless of sprue position
- > Easy assembly/disassembly of the gripper jaws
- > Jaws made of zinc-plated steel
- > Body and jaws made of anodized aluminum
- > GR04.2016S with sawtooth jaws for a higher gripping force
- > GR04.2016H with interchangeable HNBR pads for gentle gripping
- > GR04.2016HC and GR04.2016HC/NPN with replaceable HNBR pads for gentle handling
- > If a sprue detection is needed please use the grippers GR04.2016RC or GR04.2016SC with direct part detection
- > Principle of operation: single-acting
- > Medium: filtered and oiled/unoled air
- > Ambient air temperature: -20°C to +80°C (-4 °F to 176 °F)

### Technical data

Item no.	Jaw	Max. operating pressure [bar (psi)]	Sensor	Electric connection	Cable length [mm]	Closing force at 6 bar (87 psi) [N]	Weight [g]	Accessories
GR04.2016R	Standard	6 (87)	without	--	--	52	148	--
GR04.2016S	Sawtooth jaws straight	6 (87)	without	--	--	52	148	--
GR04.2016H	HNBR Pad	6 (87)	without	--	--	52	148	HNBR pad: GR04.130C-4 HNBR
GR04.2016RC	Standard	6 (87)	PNP, direct monitoring	3-pin male M8 connector	200	52	165	Connecting cable: 20.503
GR04.2016RC/NPN	Standard	6 (87)	NPN, direct monitoring	3-pin male M8 connector	200	52	165	Connecting cable: 20.503
GR04.2016SC	Sawtooth jaws straight	6 (87)	PNP, direct monitoring	3-pin male M8 connector	200	52	168	Connecting cable: 20.503
GR04.2016SC/NPN	Sawtooth jaws straight	6 (87)	NPN, direct monitoring	3-pin male M8 connector	200	52	168	Connecting cable: 20.503
GR04.2016HC	HNBR Pad	6 (87)	PNP, direct monitoring	3-pin male M8 connector	200	52	156	Connecting cable: 20.503 Set of HNBR pads: KIT-GR04.2016HNBR
GR04.2016HC/NPN	HNBR Pad	6 (87)	NPN, direct monitoring	3-pin male M8 connector	200	52	156	Connecting cable: 20.503 Set of HNBR pads: KIT-GR04.2016HNBR



Dimensions

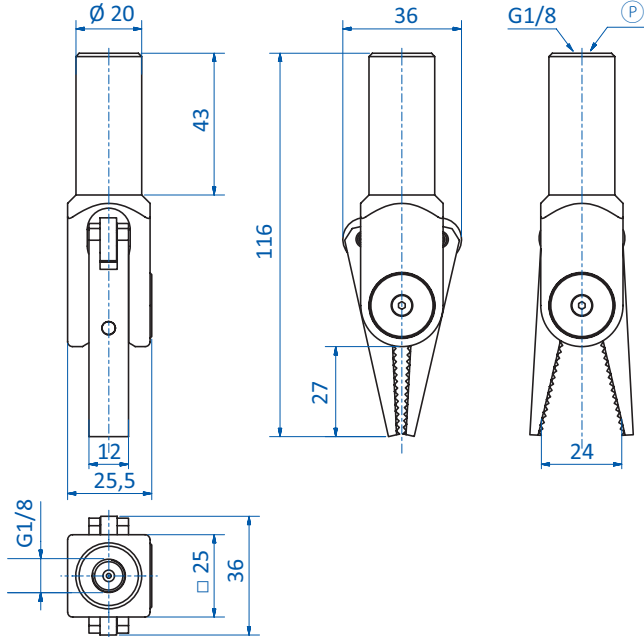

GR04.2016R

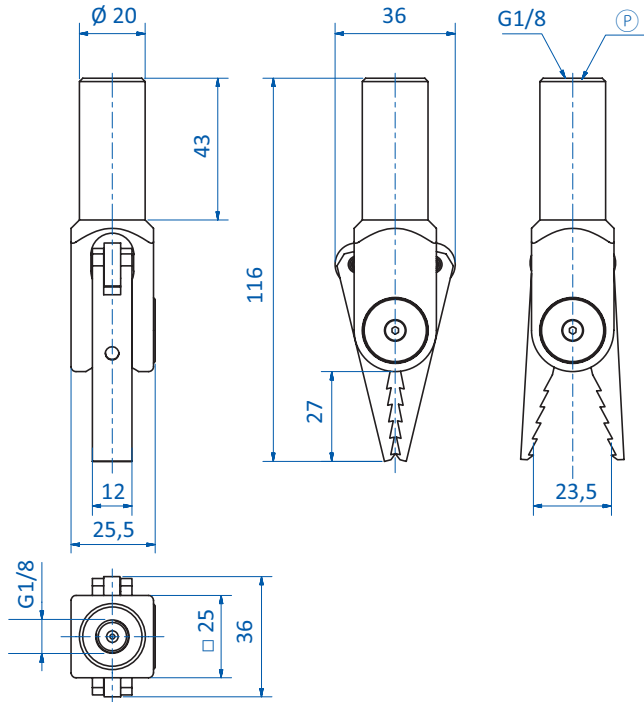

GR04.2016S

Ⓟ = Compressed air connection

Continued on the next page →



# Grippers | Sprue grippers

Series 2016 – sprue grippers, clamping diameter 20 mm – single-acting

## Dimensions

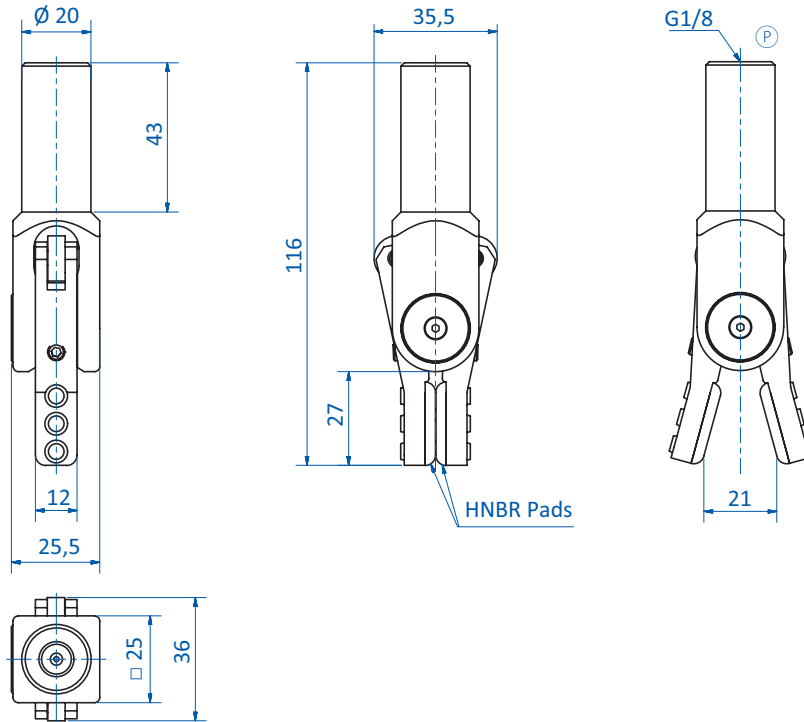

GR04.2016H

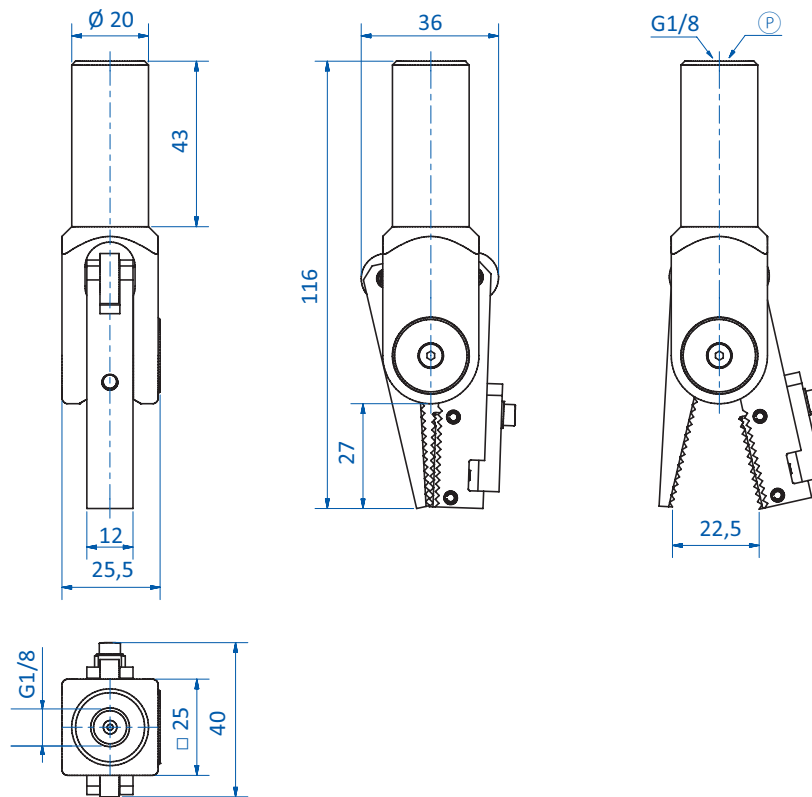

GR04.2016RC | GR04.2016RC/NPN

Ⓟ = Compressed air connection





Dimensions

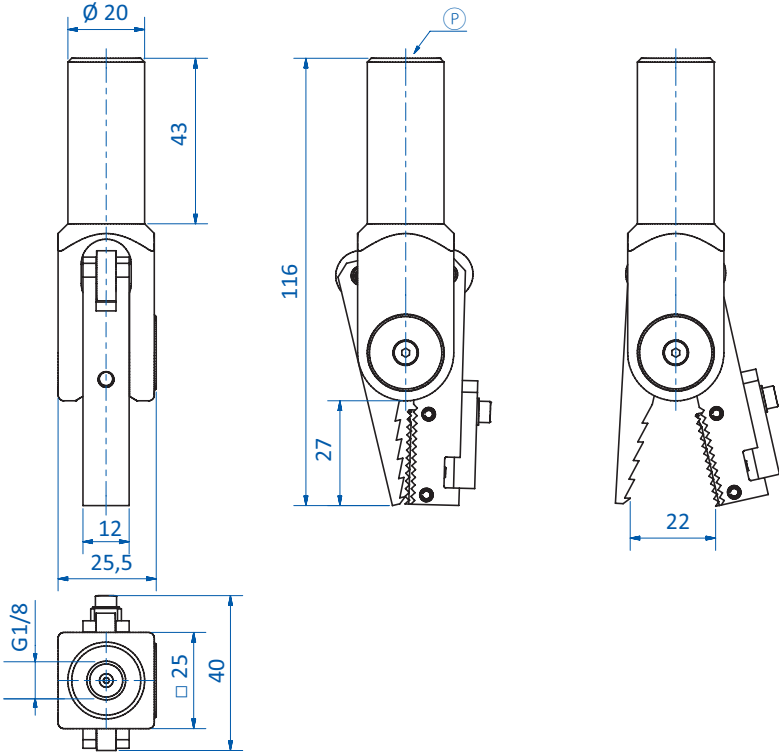

GR04.2016SC | GR04.2016SC/NPN

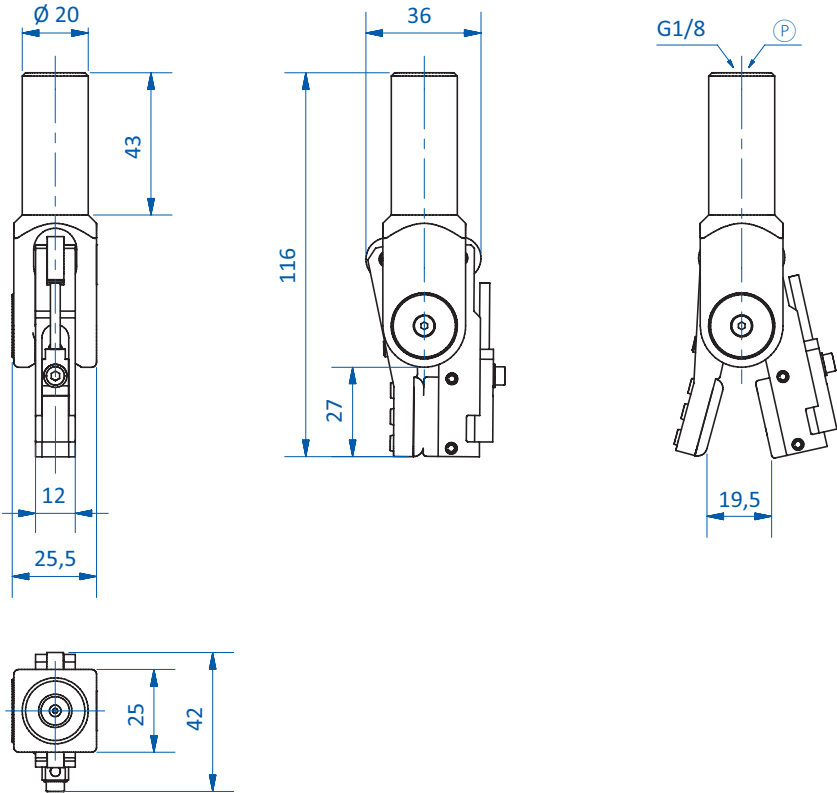

GR04.2016HC | GR04.2016HC/NPN

Ⓟ = Compressed air connection



# Grippers | Sprue grippers

Series 110 – sprue gripper – single-acting

## Series 110 – sprue gripper – single-acting



### Product notes

- > Space-saving mounting options
- > GR04.110:
  - Gap-free closing for reliably gripping small or flat sprues
  - Large jaw opening also allow for larger sprue diameter to be handled
- > GR04.111:
  - For handling sprues with a minimum thickness of 2 mm
  - Indirect sensing triggering the sensor, when no part is gripped

### Technical data

Item no.	Jaw	Max. operating pressure [bar (psi)]	Sensor	Electric connection	Cable length [mm]	Closing force at 6 bar (87 psi) [N]	Weight [g]	Suitable fittings
<b>GR04.110B</b>	Standard	8 (116)	without	3-pin male M8 connector	--	95	130	--
<b>GR04.110A</b>	Standard	8 (116)	PNP, direct monitoring, one freely adjustable switching point	3-pin male M8 connector	200	95	130	--
<b>GR04.110A/NPN</b>	Standard	8 (116)	NPN, direct monitoring, one freely adjustable switching point	3-pin male M8 connector	200	95	130	--
<b>GR04.111A</b>	Xwide	8 (116)	PNP, indirect monitoring, one freely adjustable switching point	3-pin male M8 connector	650	95	135	GR04.196A
<b>GR04.111A/NPN</b>	Xwide	8 (116)	NPN, indirect monitoring, one freely adjustable switching point	3-pin male M8 connector	340	95	135	GR04.196A



Dimensions

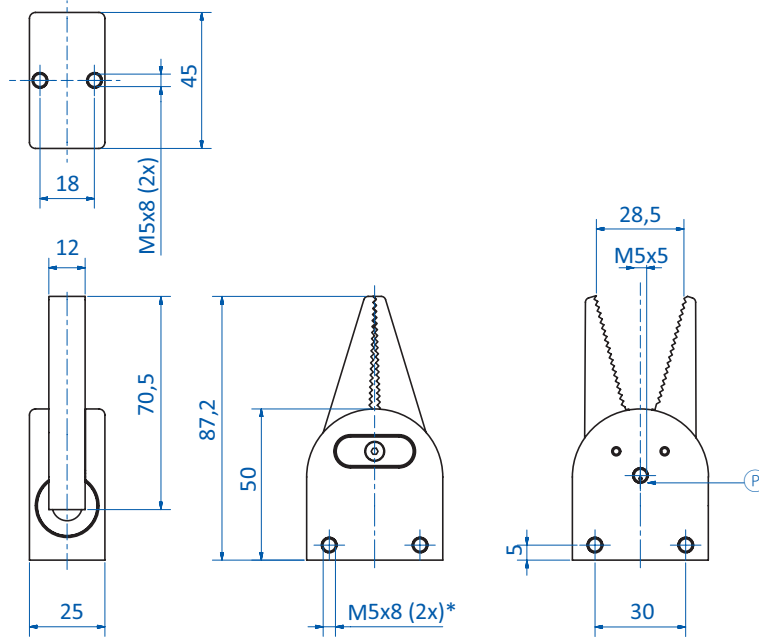

GR04.110B

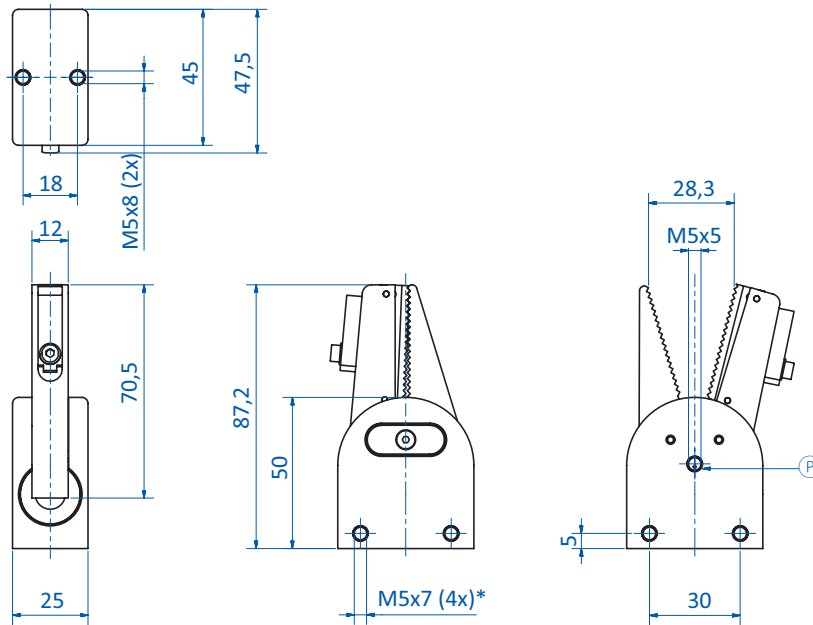

GR04.110A | GR04.110A/NPN

Ⓟ = Compressed air connection \* = Fixing hole

Continued on the next page →



# Grippers | Sprue grippers

Series 110 – sprue gripper – single-acting

## Dimensions

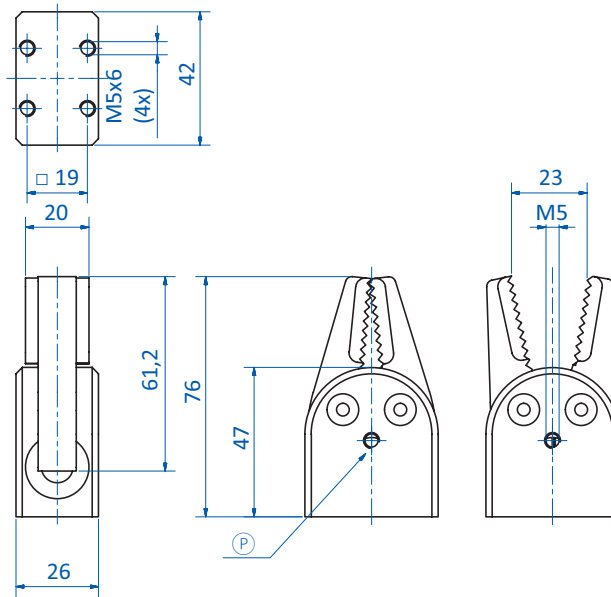

GR04.111A | GR04.111A/NPN

Ⓟ = Compressed air connection \* = Fixing hole



### Series 110 – gripper, direct mounting – double-acting



#### Product notes

- > High grip force, extra wide jaw opening and gap-free closing allow for a wide range of sprue diameters to be gripped
- > Principle of operation: double-acting

#### Technical data

Item no.	Jaw	Max. operating pressure [bar (psi)]	Sensor	Closing force at 6 bar (87 psi) [N]	Weight [g]	Suitable fittings
GR04.110	Standard	8 (116)	without	66	135	GR04.197A

#### Dimensions

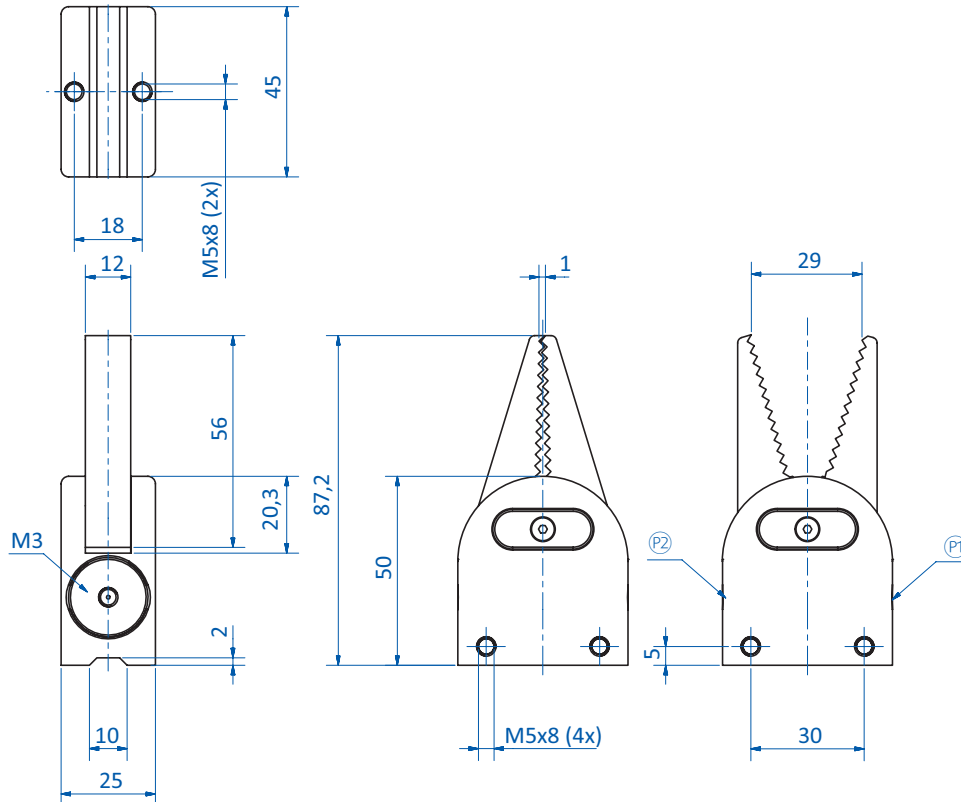

Ⓟ = Compressed air supply (open) Ⓠ = Compressed air supply (close)



### Mounting brackets for sprue grippers Series 110

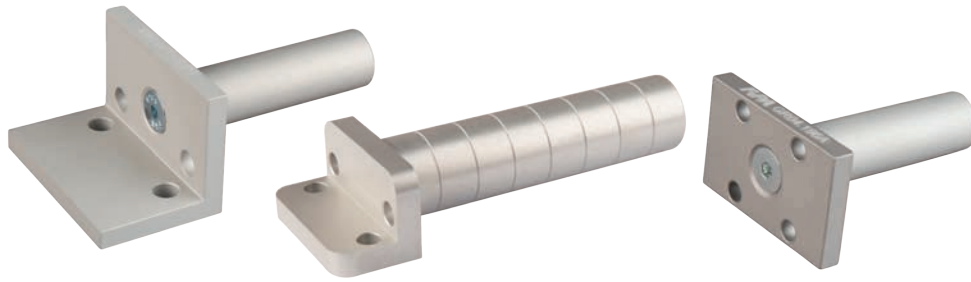

#### Technical data

Item no.	Clamping $\varnothing$ [mm]	Suitable for	Weight [g]
GR04.197A	14	GR04.110	47
GR04.197B	20	GR04.110A	47
GR04.196A	14	GR04.111A	27

#### Dimensions

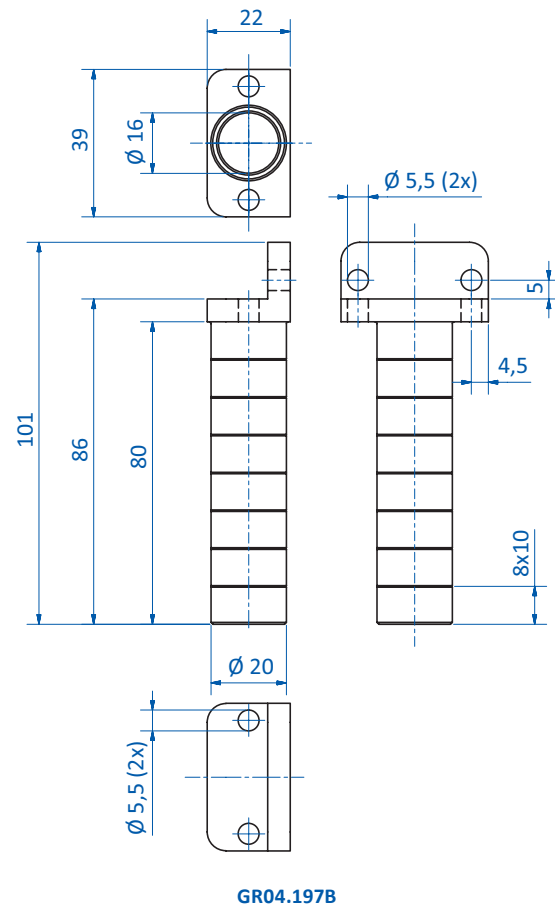
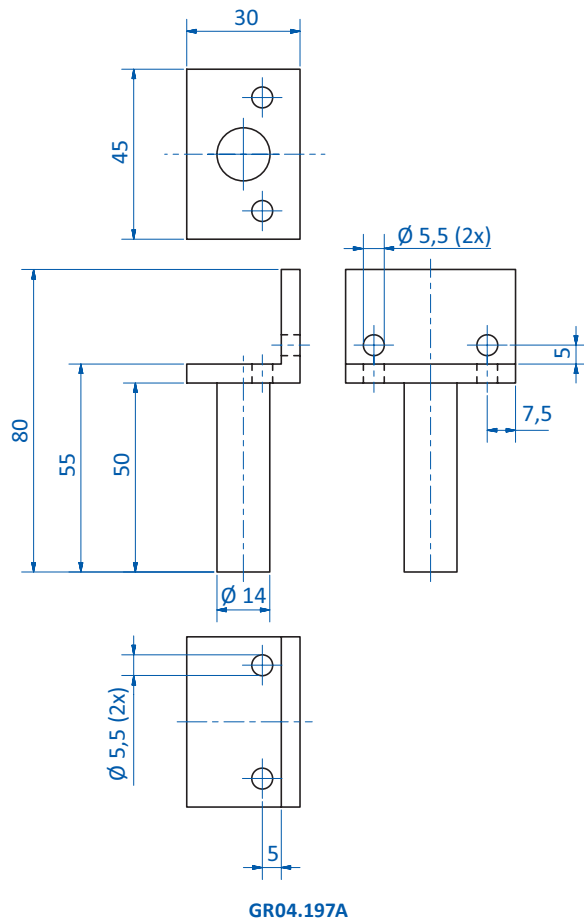



Dimensions

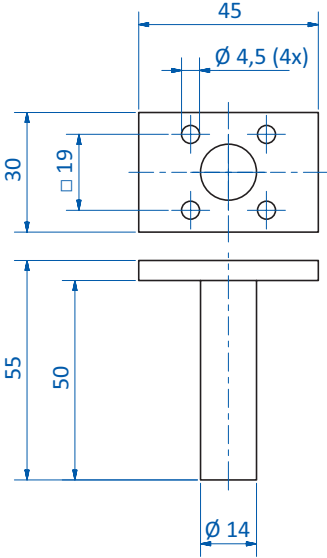

GR04.196A







### Series 120 – sprue grippers with indirect sensing



#### Product notes

- > GR04.120 for special gripper jaws
- > GR04.120LD and GR04.120DR for gates with  $\varnothing$  10 - 25 mm
- > GR04.120DR with extra wide gripper jaws
- > Principle of operation: single-acting NO, can also be operated double-acting

#### Technical data

Item no.	Jaw	Operating pressure [bar (psi)]	Sensor	Closing force at 6 bar (87 psi) [N]	Max. sprue diameter [mm]	Weight [g]	Spare pair of jaws
<b>GR04.120</b>	Universal	8 (116)	optional	--	--	141	--
<b>GR04.120LD</b>	Standard	8 (116)	optional	83	25	202	GR04.120LD-KIT
<b>GR04.120DR</b>	Xwide	8 (116)	optional	83	25	206	GR04.120LD-KIT

#### Accessories

Mounting bracket	Clamping diam. 14 mm, shaft length 50 mm	<b>GR04.196A</b>
Sensors	2 switching points teachable, 500 mm cable, 4-pin male M8 connector	PNP <b>GS04.005</b>
		NPN <b>GS04.006</b>
	Standard, 300 mm cable, 3-pin male M8 connector	PNP <b>GR04.198</b>
		NPN <b>GR04.198/NPN</b>
Connecting cables	4-pin female M8 straight, unterminated cable, 5 m long	<b>20.501</b>
	3-pin female M8 straight, unterminated cable, 2 m long	<b>20.503</b>
	3-pin female M8 90°, unterminated cable, 2 m long	<b>20.507</b>
Extension cables	3-pin female M8, 3-pin male M8, 0.3 m long	<b>20.504</b>
	3-pin female M8, 3-pin male M8, 1.5 m long	<b>20.570</b>
Adapter	4-pin female M8 to 3-pin male M8 (one signal is lost)	<b>M8B4 / M8S3</b>
Connectors	3-pin male M8	<b>20.528</b>



### Dimensions

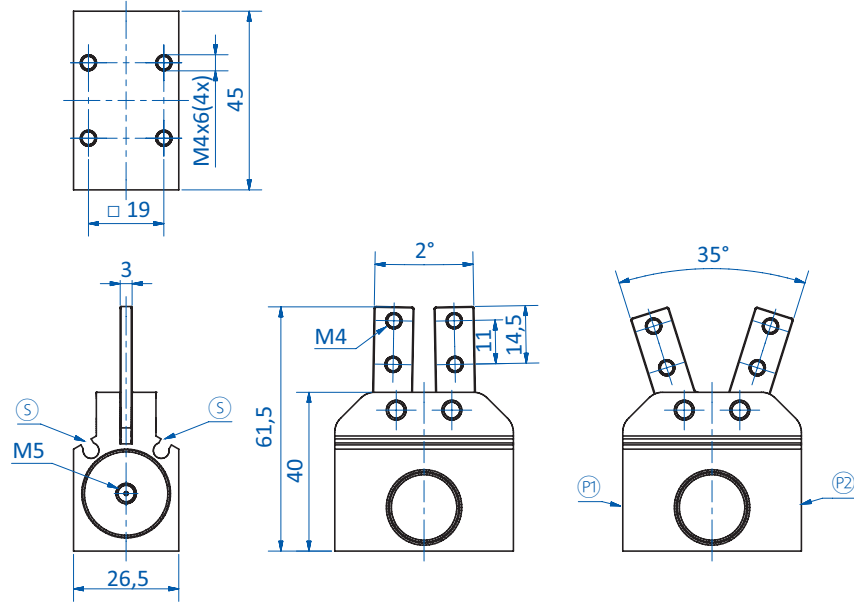

GR04.120

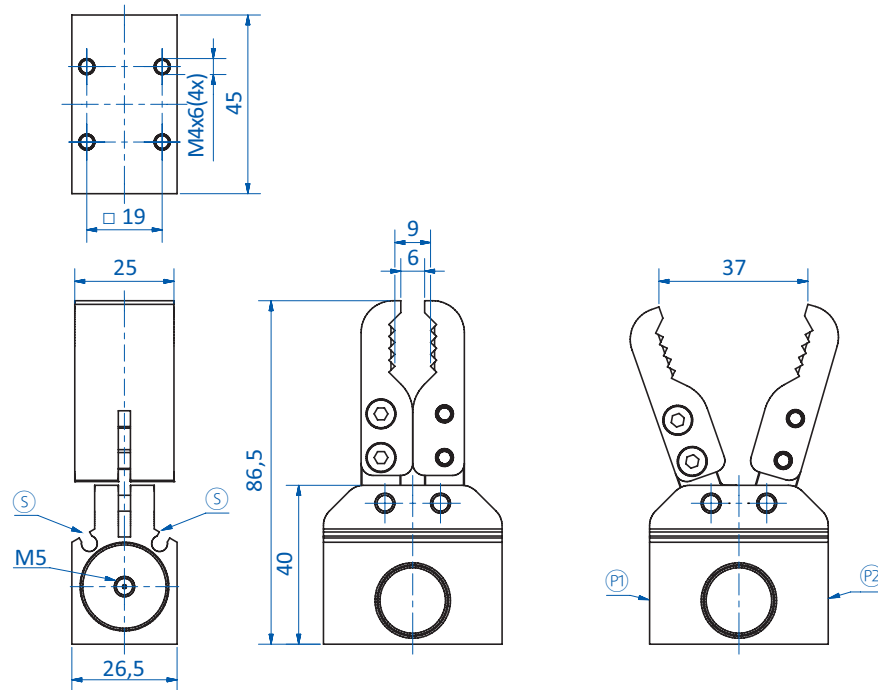

GR04.120LD

P1 = Compressed air supply (open) P2 = Compressed air supply (close) S = Sensor slot



Dimensions

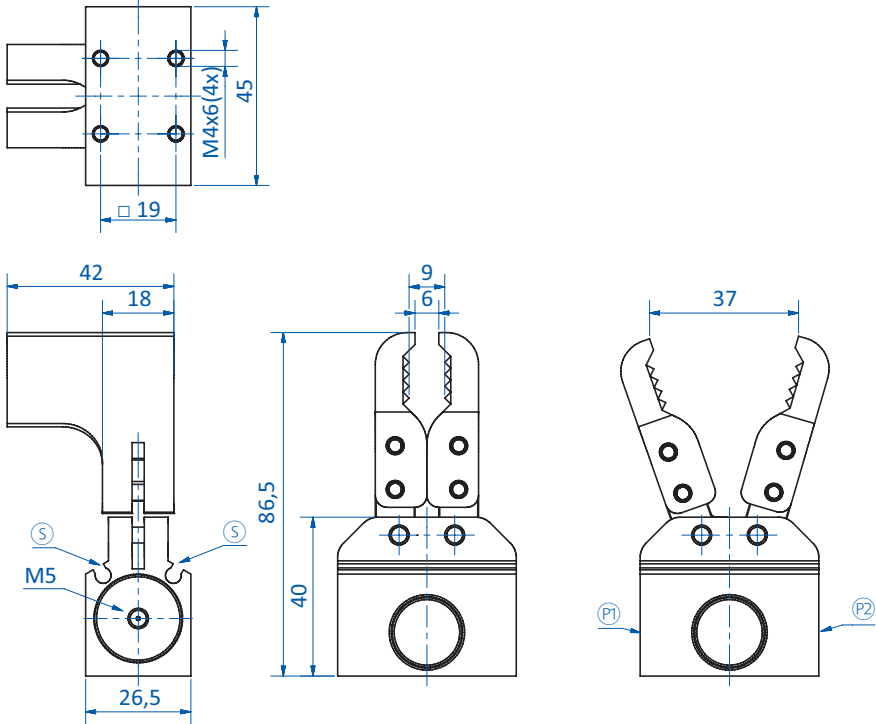

GR04.120DR

Ⓟ = Compressed air supply (open) Ⓠ = Compressed air supply (close) Ⓢ = Sensor slot



### Series 332 – power grippers without stroke – double-acting



#### Product notes

- > Strong, double-action power gripper
- > Ideally suited for demoulding large components in particular
- > Optionally available with direct sensor scanning (Sensor with 3-pin male and M8 connector included in scope of delivery)
- > Clamping force measured at the jaw tip
- > The end positions of the lifting cylinders can be sensed with optional sensors
- > Standard clamping diameter 20 mm, available on request with clamping diameter 30 mm.
- > Other customer-specific designs or adaptations are possible and easy to implement – please contact our sales department

#### Technical data

Item no.	Jaw	Sensor	Closing force at 6 bar (87 psi) [N]	Operating pressure [bar (psi)]	Weight [g]	Accessories
<b>GR04.332</b>	Standard	without	310	0.5 - 6 (7.3 - 87)	550	Sensor: GS04.001 Sensor: GR04.202N Sensor: GR04.202P Sensor: GR04.280N Sensor: GR04.280P
<b>GR04.332-1P</b>	Standard	PNP	310	0.5 - 6 (7.3 - 87)	570	Sensor: GS04.001 Sensor: GR04.202N Sensor: GR04.202P Sensor: GR04.280N Sensor: GR04.280P
<b>GR04.332H</b>	HNBR Pad	without	310	0.5 - 6 (7.3 - 87)	590	Sensor: GS04.001 Sensor: GR04.202N Sensor: GR04.202P Sensor: GR04.280N Sensor: GR04.280P HNBR pad: GR04.042-HNBR

#### Jaw

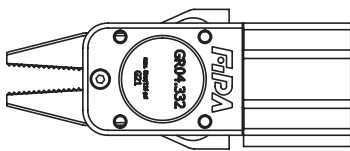

Standard without sensor

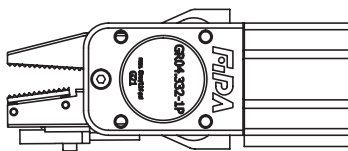

Standard with sensor

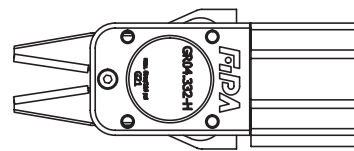

HNBR Pad



Dimensions

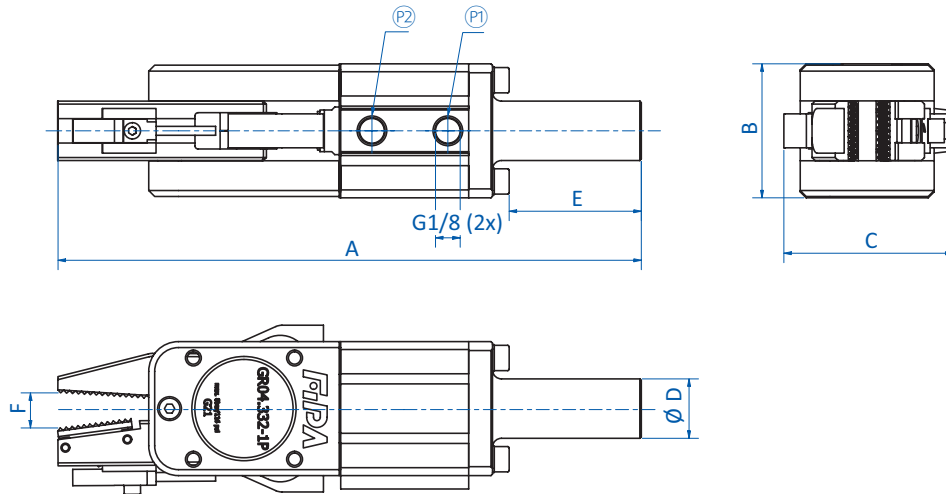

Ⓟ = Compressed air supply (close) Ⓠ = Compressed air supply (open)

Item no.	A [mm]	B [mm]	C [mm]	Ø D [mm]	E [mm]	F [mm]
<b>GR04.332</b>	197	94.05	56	20	44	11
<b>GR04.332-1P</b>	197	94.05	57	20	44	12
<b>GR04.332H</b>	197	94.05	56	20	44	11



# Grippers | Power grippers

Series 332 – power grippers with stroke – double-acting

## Series 332 – power grippers with stroke – double-acting

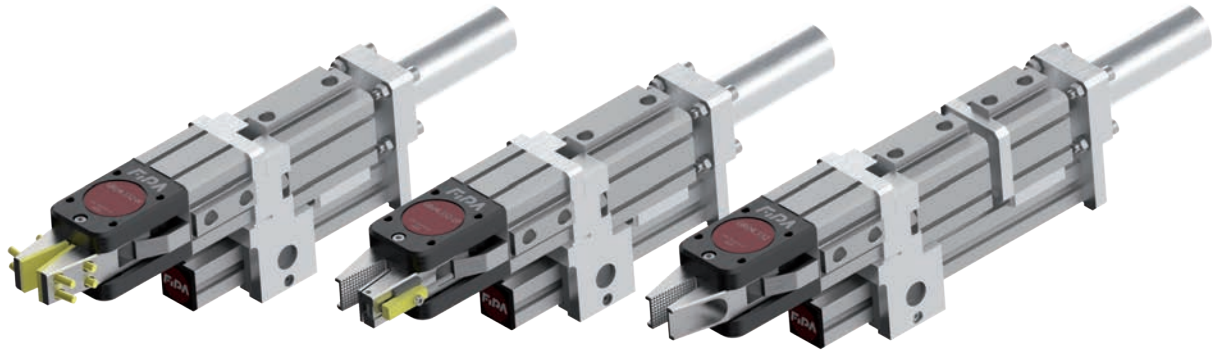

### Product notes

- > Strong, double-action power gripper with single or double stroke
- > Ideally suited for matrix removal, especially of large components
- > Optionally available with direct sensor scanning (Sensor with 3-pin male and M8 connector included in scope of delivery)
- > Clamping force measured at the jaw tip
- > The end positions of the lifting cylinders can be sensed with optional sensors
- > Optional stroke limiters are available for easy adjustment of the cylinder stroke
- > Standard clamping diameter  $\varnothing$  30 mm, available on request with clamping diameter  $\varnothing$  20 mm
- > Other customer-specific designs or adaptations are possible and easy to implement – please contact our sales department

### Technical data

Item no.	Jaw	Stroke 1 [mm]	Stroke 2 [mm]	Sensor	Closing force at 6 bar (87 psi) [N]	Lifting force at 6 bar (87 psi) [N]	Operating pressure [bar (psi)]	Weight [g]	Accessories
<b>GR04.332-30</b>	Standard	30	without	without	310	480	0.5 - 6 (7.3 - 87)	1,340	Sensor: GR04.202N Sensor: GR04.202P Sensor: GR04.280N Sensor: GR04.280P Stroke limiters: GR04.330-KIT
<b>GR04.332-40</b>	Standard	40	without	without	310	480	0.5 - 6 (7.3 - 87)	1,370	Sensor: GR04.202N Sensor: GR04.202P Sensor: GR04.280N Sensor: GR04.280P Stroke limiters: GR04.330-KIT
<b>GR04.332-30-1P</b>	Standard	30	without	PNP	310	480	0.5 - 6 (7.3 - 87)	1,370	Sensor: GS04.001 Sensor: GR04.202N Sensor: GR04.202P Sensor: GR04.280N Sensor: GR04.280P Stroke limiters: GR04.330-KIT
<b>GR04.332-40-1P</b>	Standard	40	without	PNP	310	480	0.5 - 6 (7.3 - 87)	1,400	Sensor: GS04.001 Sensor: GR04.202N Sensor: GR04.202P Sensor: GR04.280N Sensor: GR04.280P Stroke limiters: GR04.330-KIT
<b>GR04.332-20-10</b>	Standard	20	10	without	310	480	0.5 - 6 (7.3 - 87)	1,520	Sensor: GR04.202N Sensor: GR04.202P Sensor: GR04.280N Sensor: GR04.280P Stroke limiters: GR04.330-KIT
<b>GR04.332-20-20</b>	Standard	20	20	without	310	480	0.5 - 6 (7.3 - 87)	1,550	Sensor: GR04.202N Sensor: GR04.202P Sensor: GR04.280N Sensor: GR04.280P Stroke limiters: GR04.330-KIT



Technical data

Item no.	Jaw	Stroke 1 [mm]	Stroke 2 [mm]	Sensor	Closing force at 6 bar (87 psi) [N]	Lifting force at 6 bar (87 psi) [N]	Operating pressure [bar (psi)]	Weight [g]	Accessories
<b>GR04.332-20-30</b>	Standard	20	30	without	310	480	0.5 - 6 (7.3 - 87)	1,580	Sensor: GR04.202N Sensor: GR04.202P Sensor: GR04.280N Sensor: GR04.280P Stroke limiters: GR04.330-KIT
<b>GR04.332-20-50</b>	Standard	20	50	without	310	480	0.5 - 6 (7.3 - 87)	1,690	Sensor: GR04.202N Sensor: GR04.202P Sensor: GR04.280N Sensor: GR04.280P Stroke limiters: GR04.330-KIT
<b>GR04.332-20-10-1P</b>	Standard	20	10	PNP	310	480	0.5 - 6 (7.3 - 87)	1,540	Sensor: GS04.001 Sensor: GR04.202N Sensor: GR04.202P Sensor: GR04.280N Sensor: GR04.280P Stroke limiters: GR04.330-KIT
<b>GR04.332-20-20-1P</b>	Standard	20	20	PNP	310	480	0.5 - 6 (7.3 - 87)	1,570	Sensor: GS04.001 Sensor: GR04.202N Sensor: GR04.202P Sensor: GR04.280N Sensor: GR04.280P Stroke limiters: GR04.330-KIT
<b>GR04.332-20-30-1P</b>	Standard	20	30	PNP	310	480	0.5 - 6 (7.3 - 87)	1,600	Sensor: GS04.001 Sensor: GR04.202N Sensor: GR04.202P Sensor: GR04.280N Sensor: GR04.280P Stroke limiters: GR04.330-KIT
<b>GR04.332-30H</b>	HNBR Pad	30	without	without	310	480	0.5 - 6 (7.3 - 87)	1,380	Sensor: GR04.202N Sensor: GR04.202P Sensor: GR04.280N Sensor: GR04.280P Stroke limiters: GR04.330-KIT

Jaw

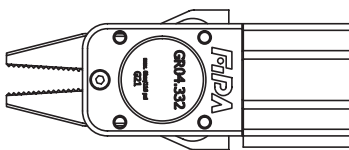

Standard without sensor

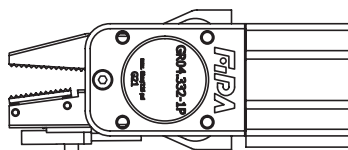

Standard with sensor

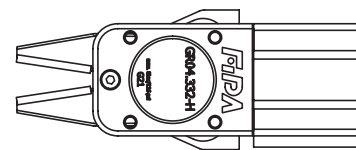

HNBR Pad

Continued on the next page →



# Grippers | Power grippers

Series 332 – power grippers with stroke – double-acting

## Dimensions

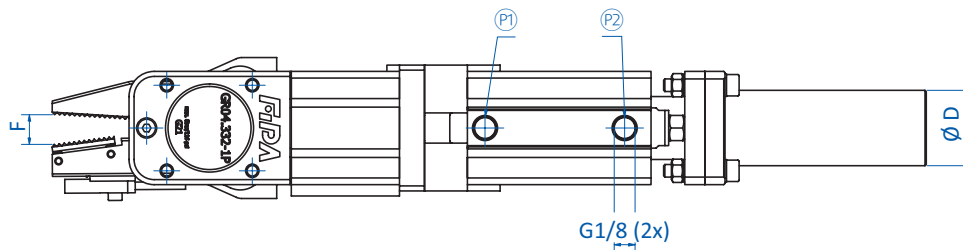
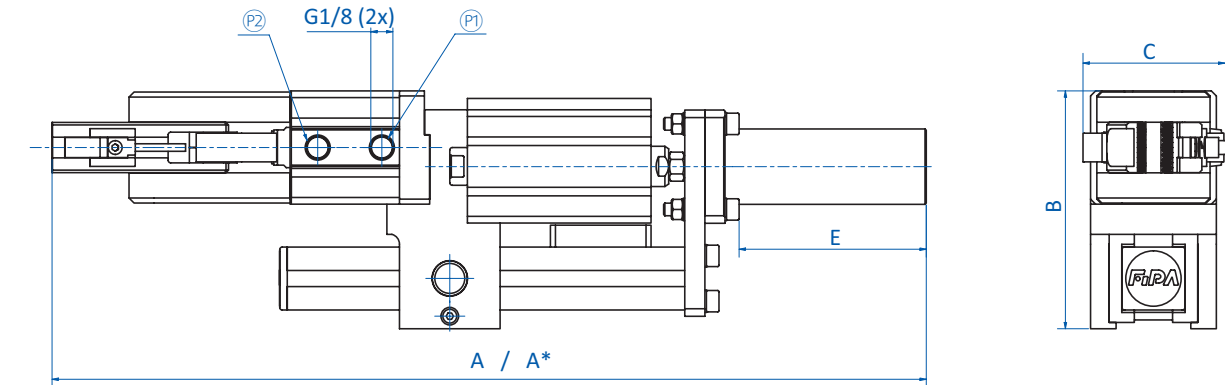

GR04.332-30 | GR04.332-40 | GR04.332-30-1P | GR04.332-40-1P | GR04.332-30H

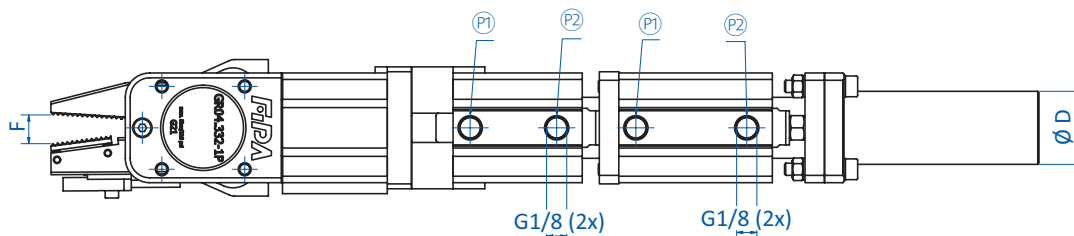
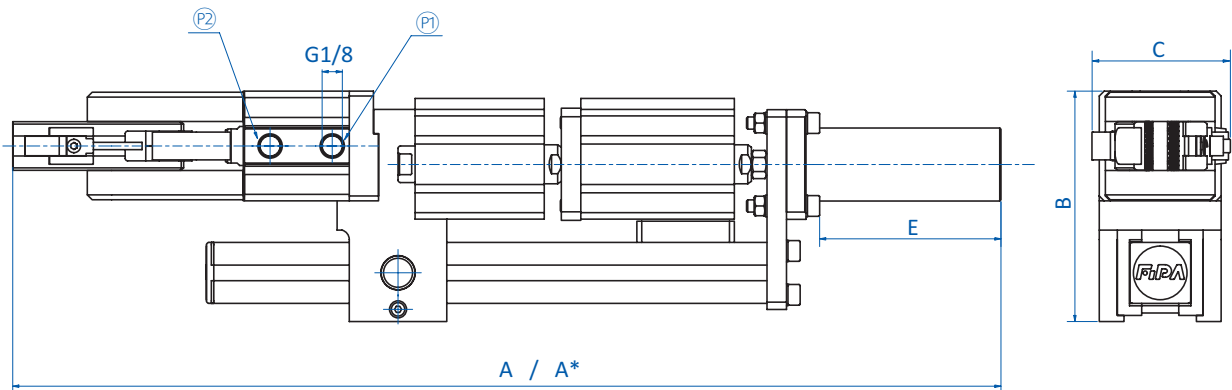

GR04.332-20-10 | GR04.332-20-20 | GR04.332-20-30 | GR04.332-20-50 | GR04.332-20-10-1P | GR04.332-20-20-1P | GR04.332-20-30-1P

$\textcircled{P1}$  = Compressed air connection cylinder extended / gripper close  $\textcircled{P2}$  = Compressed air connection cylinder retracted / gripper open  
 \* = Length  $A^* = A + \text{Stroke 1} + \text{Stroke 2}$





Item no.	A [mm]	A* [mm]	B [mm]	C [mm]	Ø D [mm]	E [mm]	F [mm]
<b>GR04.332-30</b>	338	368	94.5	56	30	74	10
<b>GR04.332-40</b>	348	388	94.5	56	30	74	10
<b>GR04.332-30-1P</b>	338	368	94.5	57	30	74	11
<b>GR04.332-40-1P</b>	348	388	94.5	57	30	74	11
<b>GR04.332-20-10</b>	386	416	94.5	56	30	74	10
<b>GR04.332-20-20</b>	396	436	94.5	56	30	74	10
<b>GR04.332-20-30</b>	406	456	94.5	56	30	74	10
<b>GR04.332-20-50</b>	425.5	495.5	94.5	50	30	74	10
<b>GR04.332-20-10-1P</b>	386	416	94.5	57	30	74	11
<b>GR04.332-20-20-1P</b>	396	436	94.5	57	30	74	11
<b>GR04.332-20-30-1P</b>	406	456	94.5	57	30	74	11
<b>GR04.332-30H</b>	308	338	94.5	56	30	74	11



# Grippers | Power grippers

Series 325 – power grippers without stroke – single-acting

## Series 325 – power grippers without stroke – single-acting



### Product notes

- > Very strong, single-action power gripper
- > Ideally suited for demoulding large components in particular
- > Optionally available with direct sensor scanning (Sensor with 3-pin male and M8 connector included in scope of delivery)
- > Clamping force measured at the jaw tip
- > The end positions of the lifting cylinders can be sensed with optional sensors
- > Standard clamping diameter 30 mm, available on request with clamping diameter 20 mm
- > Other customer-specific designs or adaptations are possible and easy to implement – please contact our sales department

### Technical data

Item no.	Jaw	Sensor	Closing force at 6 bar (87 psi) [N]	Operating pressure [bar (psi)]	Weight [g]	Suitable sensors
GR04.325A	Standard	without	365	2.5 - 6 (36.3 - 87)	352	--
GR04.325A-1P	Standard	PNP	365	2.5 - 6 (36.3 - 87)	381	GS04.001
GR04.325A-1N	Standard	NPN	365	2.5 - 6 (36.3 - 87)	381	GS04.002

### Dimensions

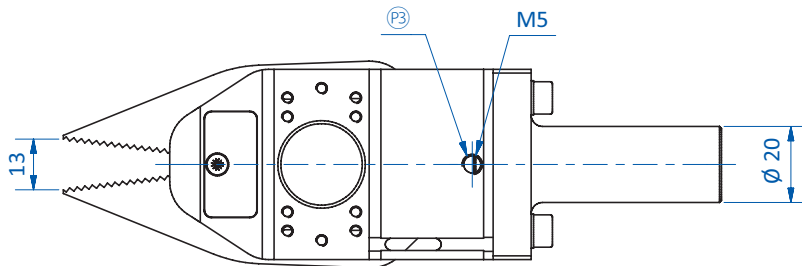
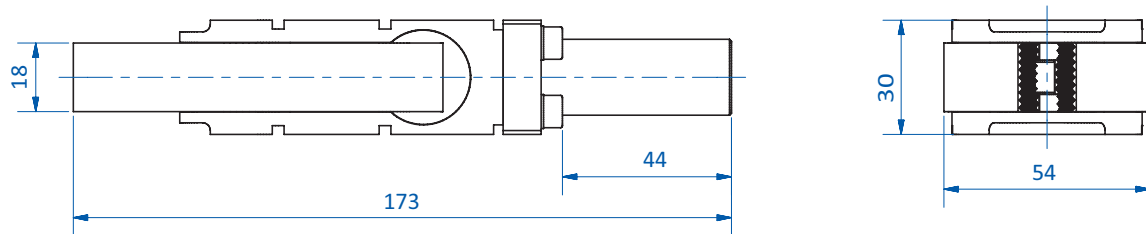

GR04.325A

Ⓟ = Compressed air connection gripper



### Dimensions

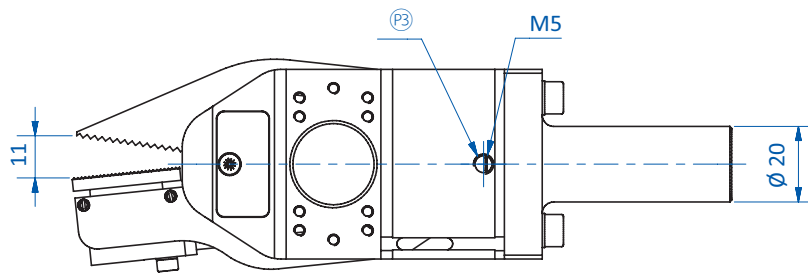
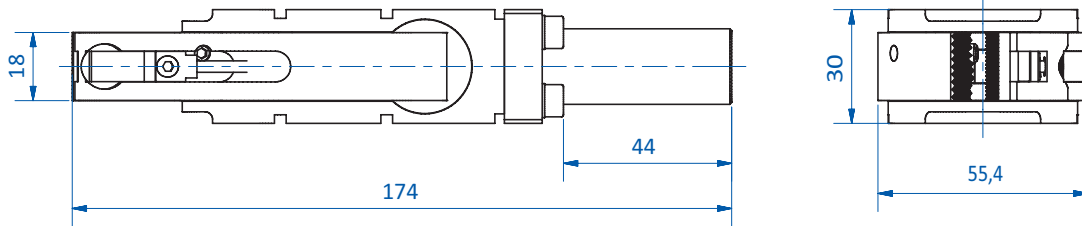

GR04.325A-1P | GR04.325A-1N

Ⓟ = Compressed air connection gripper



# Grippers | Gripper fingers

## 95° Gripper fingers

### 95° Gripper fingers



#### Product notes

- > Single-acting, spring return
- > Body and jaws made of anodized aluminum alloy
- > Optionally available sensors:
  - For GR04.034 with optional sensor holder GR04.038S: GR04.198 (1x PNP) and GR04.198/NPN (1x NPN), output M8 3-pole  
Suitable connection cable (2 m): 20.503  
Suitable connecting cable (0.3 m): 20.504
  - For GR04.044, GR04.042: GS04.005 (2x PNP) and GS04.006 (2x NPN) can be taught with two switching points, output M8 4-pole  
Suitable connection cable (5 m): 20.501

#### Technical data

Item no.	Operating pressure [bar (psi)]	Clamping Ø [mm]	Stroke [°]	Sensor nut	Closing force at 6 bar (87 psi) [N]	Weight [g]	Accessories
<b>GR04.034</b>	2 - 8 (29 - 116)	14	95	using GR04.038S	24	25	HNBR pad: GR04.034-HNBR Sensor mounting bracket: GR04.038S Stop element: GR04.034-H Stop element: GR04.036
<b>GR04.044</b>	2 - 8 (29 - 116)	20	95	Yes	70	58	HNBR pad: GR04.044-HNBR Sensor: GS04.005 Sensor: GS04.006 Stop element: GR04.044-H Stop element: GR04.046
<b>GR04.042</b>	2 - 8 (29 - 116)	30	95	Yes	135	205	HNBR pad: GR04.042-HNBR Sensor: GS04.005 Sensor: GS04.006 Stop element: GR04.042-H

#### Complete set consists of

Item no.		Gripper fingers	HNBR pad	Stop element incl. HNBR pad
<b>GR04.034-SE-HNBR</b>		GR04.034	GR04.034-HNBR	GR04.034-H
<b>GR04.044-SE-HNBR</b>		GR04.044	GR04.044-HNBR	GR04.044-H
<b>GR04.042-SE-HNBR</b>		GR04.042	GR04.042-HNBR	GR04.042-H



Dimensions

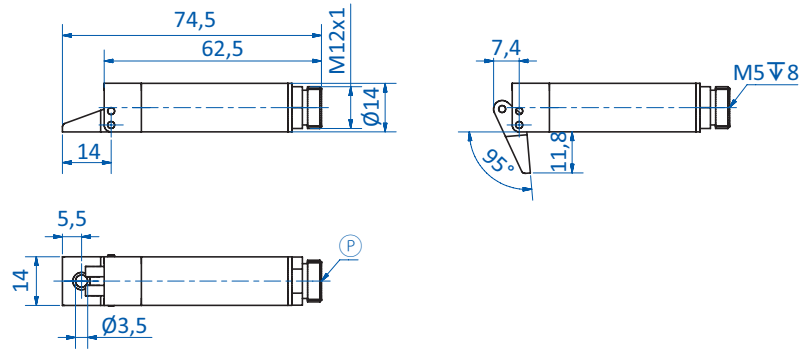

GR04.034

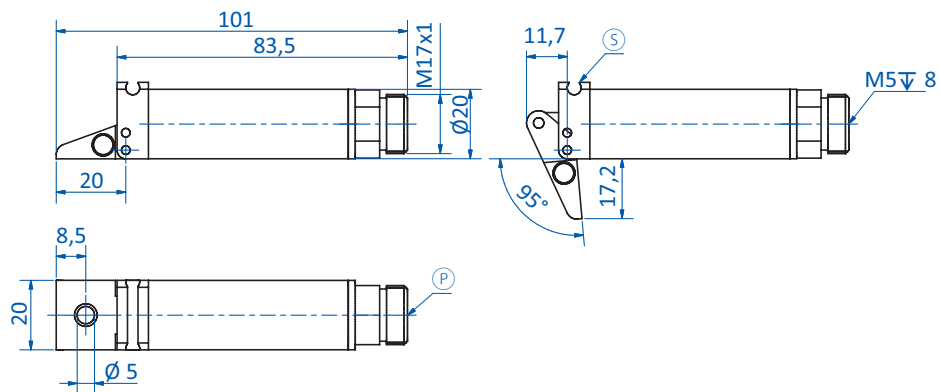

GR04.044

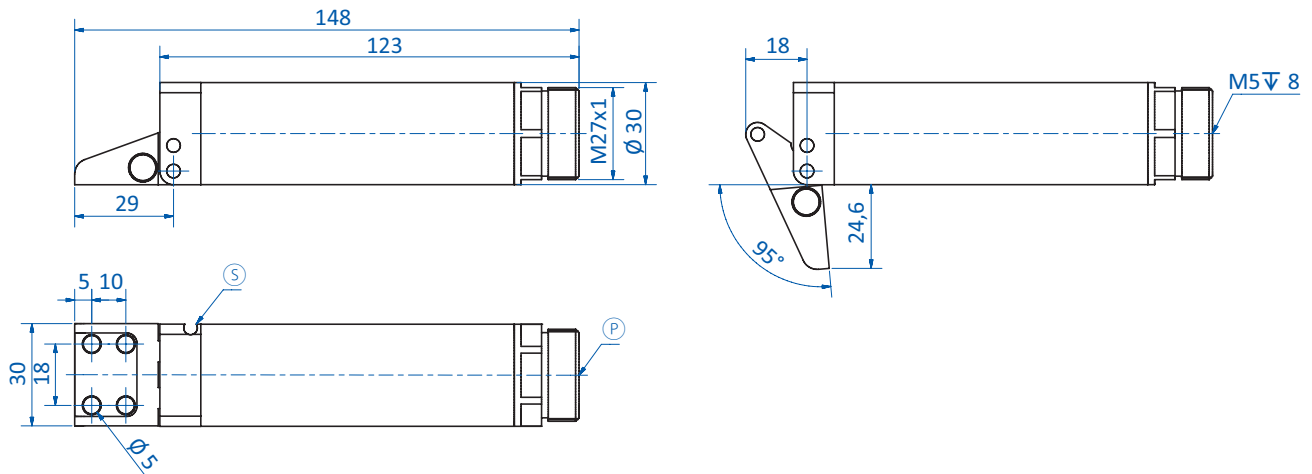

GR04.042

Ⓟ = Compressed air connection   Ⓢ = Sensor slot



# Grippers | Gripper fingers

## 35° Gripper Fingers

### 35° Gripper Fingers



#### Product notes

- > Single-acting, spring return
- > Body and jaws made of anodized aluminum alloy
- > Optionally available sensors:
  - For GR04.035 with optional sensor holder GR04.038S: GR04.198 (1x PNP) and GR04.198/NPN (1x NPN), output M8 3-pole  
Suitable connection cable (2 m): 20.503  
Suitable connecting cable (0.3 m): 20.504
  - For GR04.045, GR04.043: GS04.005 (2x PNP) and GS04.006 (2x NPN) can be taught with two switching points, output M8 4-pole  
Suitable connection cable (5 m): 20.501

#### Technical data

Item no.	Operating pressure [bar (psi)]	Clamping Ø [mm]	Stroke [°]	Sensor nut	Closing force at 6 bar (87 psi) [N]	Weight [g]	Accessories
<b>GR04.035</b>	2 - 8 (29 - 116)	14	35	using GR04.038S	23	25	Sensor mounting bracket: GR04.038S
<b>GR04.045</b>	2 - 8 (29 - 116)	20	35	Yes	65	59	Sensor: GS04.005 Sensor: GS04.006
<b>GR04.043</b>	2 - 8 (29 - 116)	30	35	Yes	214	218	Sensor: GS04.005 Sensor: GS04.006

#### Dimensions

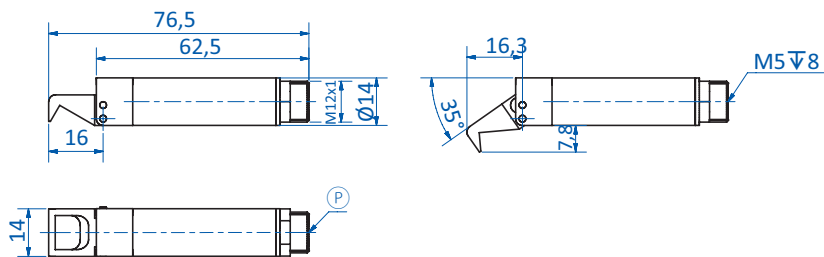

GR04.035

Ⓟ = Compressed air connection Ⓢ = Sensor slot



Dimensions

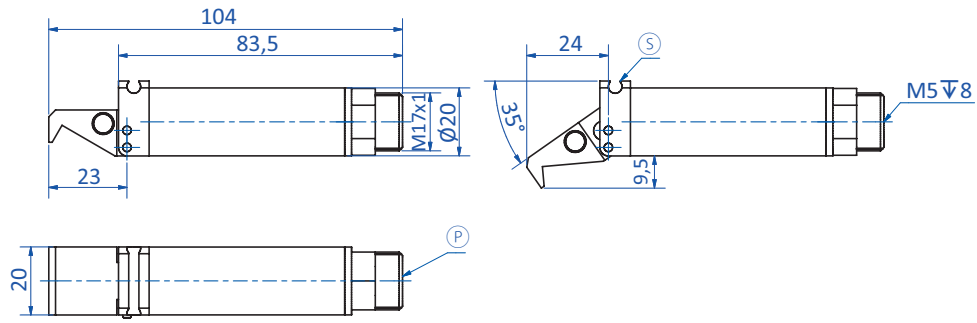

GR04.045

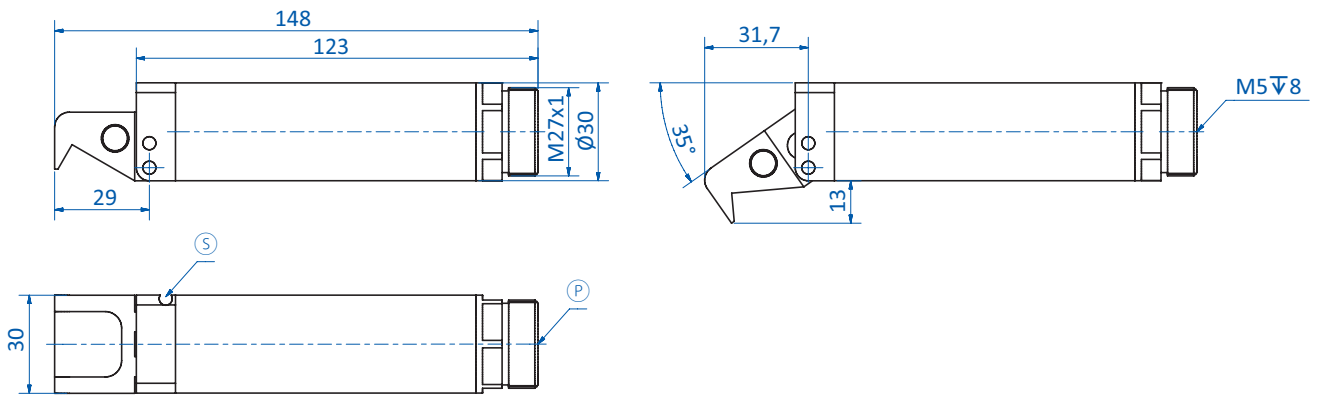

GR04.043

Ⓟ = Compressed air connection Ⓢ = Sensor slot



# Grippers | Gripper fingers

## 90° Gripper fingers

### 90° Gripper fingers



#### Product notes

- > Single-acting, spring return
- > Body and jaws made of anodized aluminum alloy
- > GR04.039 & GR04.049: optional sensors for monitoring gripper finger
- > Optional Sensors GS04.005 (2x PNP) and GS04.006 (2x NPN) with teach-in of two switching points, plug M8 4-pin
- > Optional connecting cable 20.501

#### Technical data

Item no.	Operating pressure [bar (psi)]	Clamping $\phi$ [mm]	Stroke [°]	Sensor nut	Closing force at 6 bar (87 psi) [N]	Weight [g]	Suitable sensors
GR04.038	2 - 8 (29 - 116)	14	90	Without	44	22	--
GR04.039	2 - 8 (29 - 116)	20	90	Yes	110	62	GS04.005 GS04.006
GR04.049	2 - 8 (29 - 116)	30	90	Yes	240	212	GS04.005 GS04.006

#### Dimensions

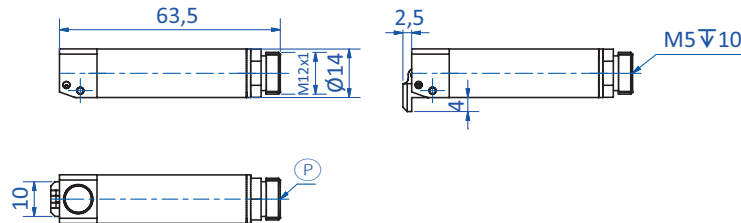

GR04.038

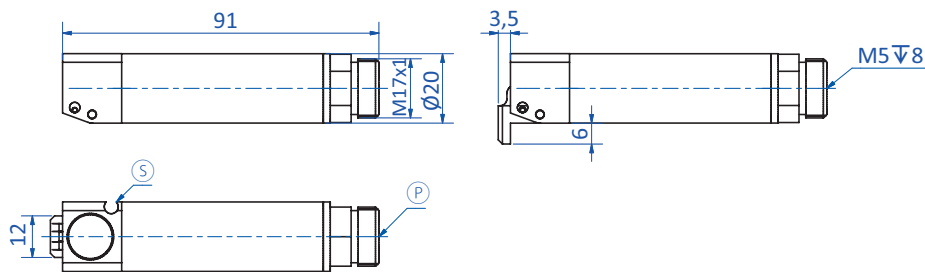

GR04.039

Ⓟ = Compressed air connection Ⓢ = Sensor slot





Dimensions

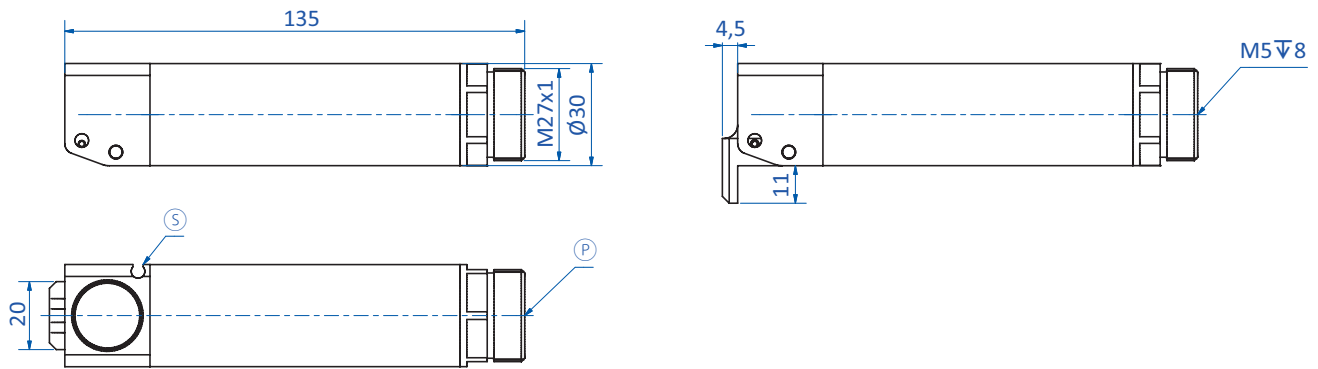

GR04.049

Ⓟ = Compressed air connection Ⓢ = Sensor slot



# Grippers | Gripper fingers

## Compact gripper fingers

### Compact gripper fingers



#### Product notes

- > Single-acting, spring return
- > Body and jaws made of high-strength aluminum alloy
- > Optional sensors GS04.005 (2x PNP) and GS04.006 (2x NPN) with teach-in of two switching points, plug M8 4-pin
- > HNBR pads/elastomers can be easily replaced
- > Spare part kits each contain six elastomers
- > The max. using temperature of the gripper is 70°C (158°F)
- > Optional connecting cable 20.501

#### Technical data

Item no.	Jaw	Operating pressure [bar (psi)]	Clamping Ø [mm]	Stroke [°]	Sensor nut	Closing force at 6 bar (87 psi) [N]	Usage temperature elastomers [°C (°F)]	Weight [g]	Accessories
<b>GR04.024H</b>	HNBR Pad	2 - 8 (29 - 116)	14	25	Yes	18	15 - 150 (59 - 302)	24	HNBR pad: GR04.024-HNBR Sensor: GS04.005 Sensor: GS04.006
<b>GR04.025FKM</b>	Elastomer FKM	2 - 8 (29 - 116)	20	22	Yes	51	15 - 200 (59 - 392)	76	Spare part kit: KIT-GR04.025FKM Sensor: GS04.005 Sensor: GS04.006
<b>GR04.025NBR</b>	Elastomer NBR	2 - 8 (29 - 116)	20	22	Yes	51	15 - 90 (59 - 194)	76	Spare part kit: KIT-GR04.025NBR Sensor: GS04.005 Sensor: GS04.006
<b>GR04.025SI</b>	Elastomer Silicone	2 - 8 (29 - 116)	20	22	Yes	51	15 - 200 (59 - 392)	76	Spare part kit: KIT-GR04.025SI Sensor: GS04.005 Sensor: GS04.006
<b>GR04.026H</b>	HNBR Pad	2 - 8 (29 - 116)	20	22	Yes	50	15 - 150 (59 - 302)	65	HNBR pad: GR04.042-HNBR Sensor: GS04.005 Sensor: GS04.006



Dimensions

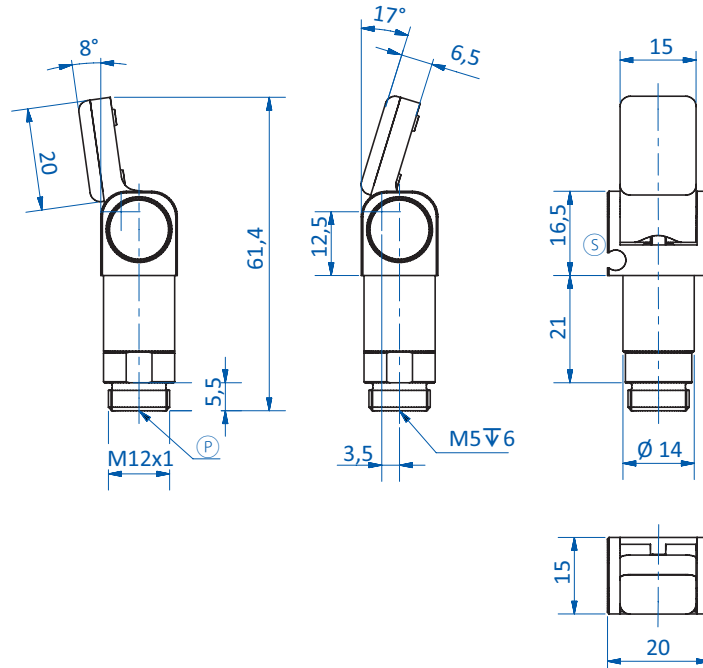

GR04.024H

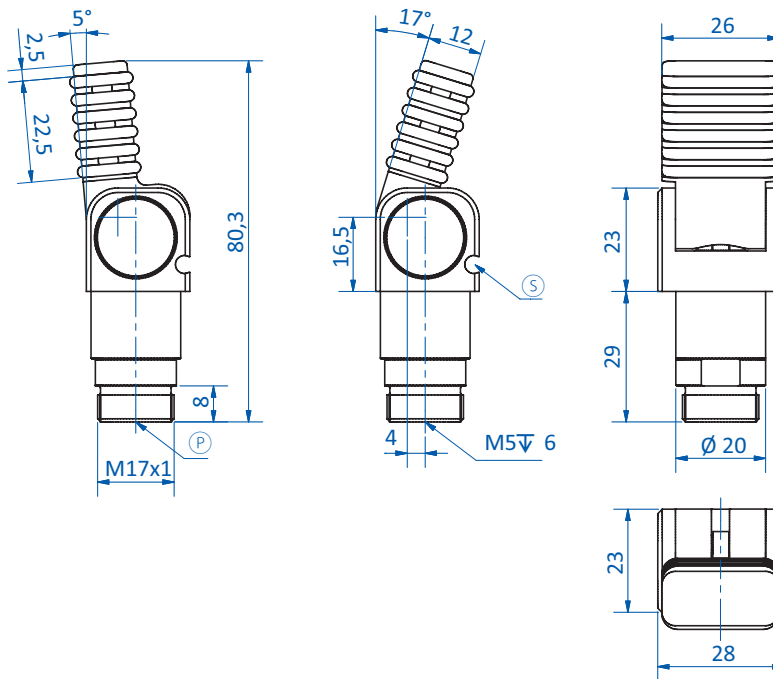

GR04.025FKM | GR04.025NBR | GR04.025SI

Ⓟ = Compressed air connection Ⓢ = Sensor slot

Continued on the next page →



### Dimensions

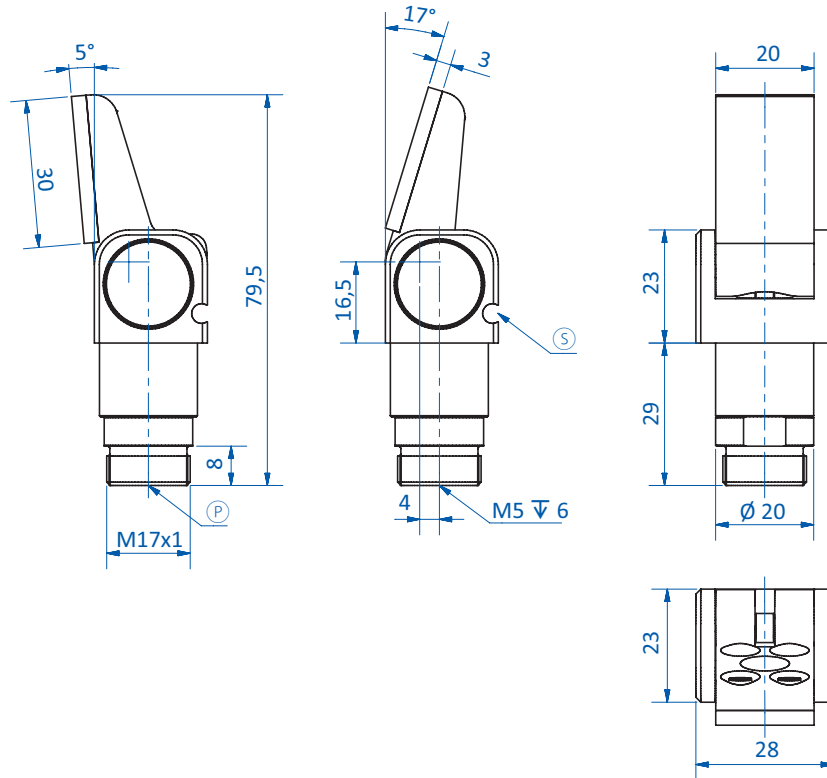

GR04.026H

Ⓟ = Compressed air connection Ⓢ = Sensor slot



## Sensor mounting bracket for gripper fingers, diameter 14 mm



### Product notes

> Made of anodized aluminum

### Technical data

Item no.	Suitable for gripper fingers	Clamping $\varnothing$ [mm]	Weight [g]	Suitable sensors
GR04.038S	GR04.034, GR04.035	14	6	GR04.198 GR04.198/NPN

### Dimensions

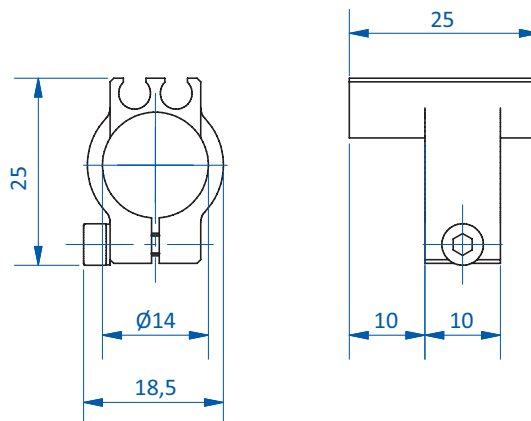



### Stop elements for gripper fingers



GR04.046 and GR04.042



GR04.042-SE-HNBR and GR04.042-H with HNBR pad

### Product notes

- > Can be used in conjunction with guide elements
- > GR04.034-H, GR04.044-H and GR04.042-H: with HNBR pads for gentle gripping of sensitive components, temperature range 0 - 160 °C (32 - 320 °F) for short term contact – up to 30 seconds

### Technical data

Item no.	Suitable for gripper fingers	Clamping $\varnothing$ [mm]	Material	Weight [g]	Replacement parts
<b>GR04.036</b>	GR04.034, GR04.035	14	POM	11	--
<b>GR04.046</b>	GR04.044, GR04.045	20	POM	16	--
<b>GR04.034-H</b>	GR04.034, GR04.035	14	Aluminum + HNBR	6	GR04.034-HNBR
<b>GR04.044-H</b>	GR04.044, GR04.045	20	Aluminum + HNBR	13	GR04.044-HNBR
<b>GR04.042-H</b>	GR04.042	30	Aluminum + HNBR	23	GR04.042-HNBR

### Dimensions

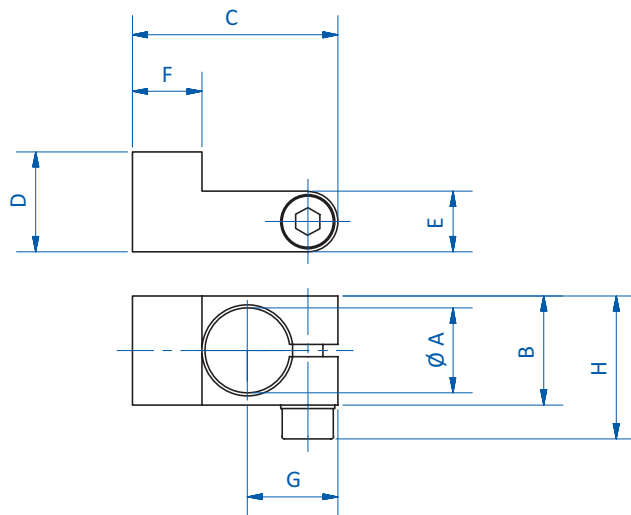

GR04.036 | GR04.046

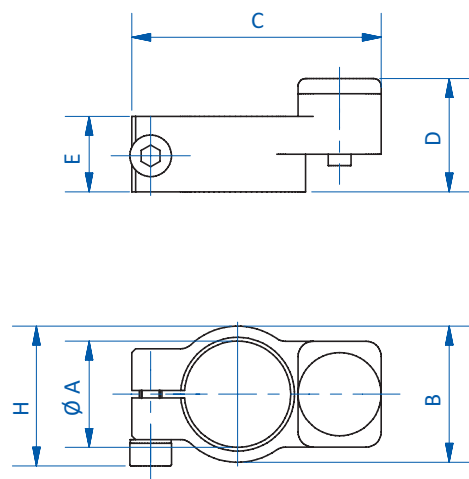

GR04.034-H | GR04.044-H



Dimensions

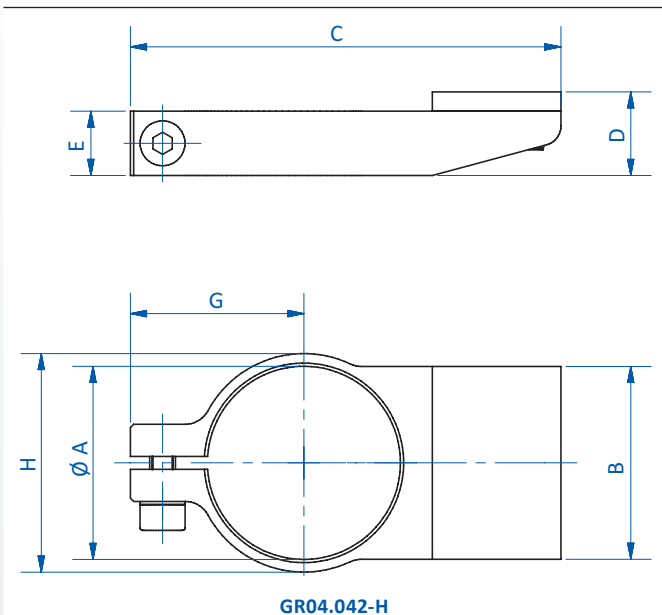

Item no.	Ø A [mm]	B [mm]	H [mm]	C [mm]	D [mm]	E [mm]	F [mm]	G [mm]
GR04.036	14	18	23.6	34	16.5	10	11.5	15
GR04.046	20	24	29.6	45	14.5	10	16.5	18
GR04.034-H	14	18	18.5	33	15	10	--	14
GR04.044-H	20	24	24	44.5	13	10	--	17
GR04.042-H	30	30	34	67	13	10	--	27

Application examples

> Gripper finger with stop element without HNBR pad



> Gripper finger with stop element with HNBR pad









### Series 126 – Parallel gripper compact



#### Product notes

- > Compact parallel gripper for small and medium-sized workpieces.
- > Double-acting for internal and external gripping as well as short cycle times, one compressed air connection each for opening and closing
- > Optional detection of the piston position
- > Self-centering gripper jaws with positioning repeatability
- > Two different finger lengths available for different space requirements

#### Technical data

Item no.	GR04.126-08-S-N	GR04.126-08-L-N	GR04.126-10-S-M	GR04.126-10-L-M	GR04.126-12-L-M	GR04.126-16-L-M	GR04.126-20-L-M
Principle of operation	double-acting	double-acting	double-acting	double-acting	double-acting	double-acting	double-acting
Operating pressure [bar (psi)]	1.5 - 7 (21.8 - 101.5)	1.5 - 7 (21.8 - 101.5)	1.5 - 7 (21.8 - 101.5)	1.5 - 7 (21.8 - 101.5)	1.5 - 7 (21.8 - 101.5)	1.5 - 7 (21.8 - 101.5)	1.5 - 7 (21.8 - 101.5)
Piston diameter [mm]	8	8	10	10	12	16	20
Stroke per gripper jaw [mm]	1.5	1.5	2	2	3	4	6
Closing force at 6 bar (87 psi) [N]	11.8	11.8	13.8	13.8	22.5	49	85
Opening force at 6 bar (87 psi) [N]	12.8	12.8	27	27	27	56	102
Gripping point distance of the closing and opening force specification [mm]	10	10	10	10	20	20	20
Max. operating frequency [1/min]	100	100	100	100	100	100	100
Jaw	short	long	short	long	long	long	long
Compressed air connection	M3	M3	M3	M3	M3	M5	M5
Sensor	no	no	optional	optional	optional	optional	optional
Ambient air temperature [°C (°F)]	0 - 60 (32 - 140)	0 - 60 (32 - 140)	0 - 60 (32 - 140)	0 - 60 (32 - 140)	0 - 60 (32 - 140)	0 - 60 (32 - 140)	0 - 60 (32 - 140)
Weight [g]	22	22	38	38	57	108	173
Accessories	Mounting bracket: GR06.126-08	Mounting bracket: GR06.126-08	Mounting bracket: GR06.126-10 Sensor: GR04.209P	Mounting bracket: GR06.126-10 Sensor: GR04.209P	Mounting bracket: GR06.126-12 Sensor: GR04.209P	Mounting bracket: GR06.126-16 Sensor: GR04.209P	Mounting bracket: GR06.126-20 Sensor: GR04.209P

Continued on the next page →



### Application examples with bracket

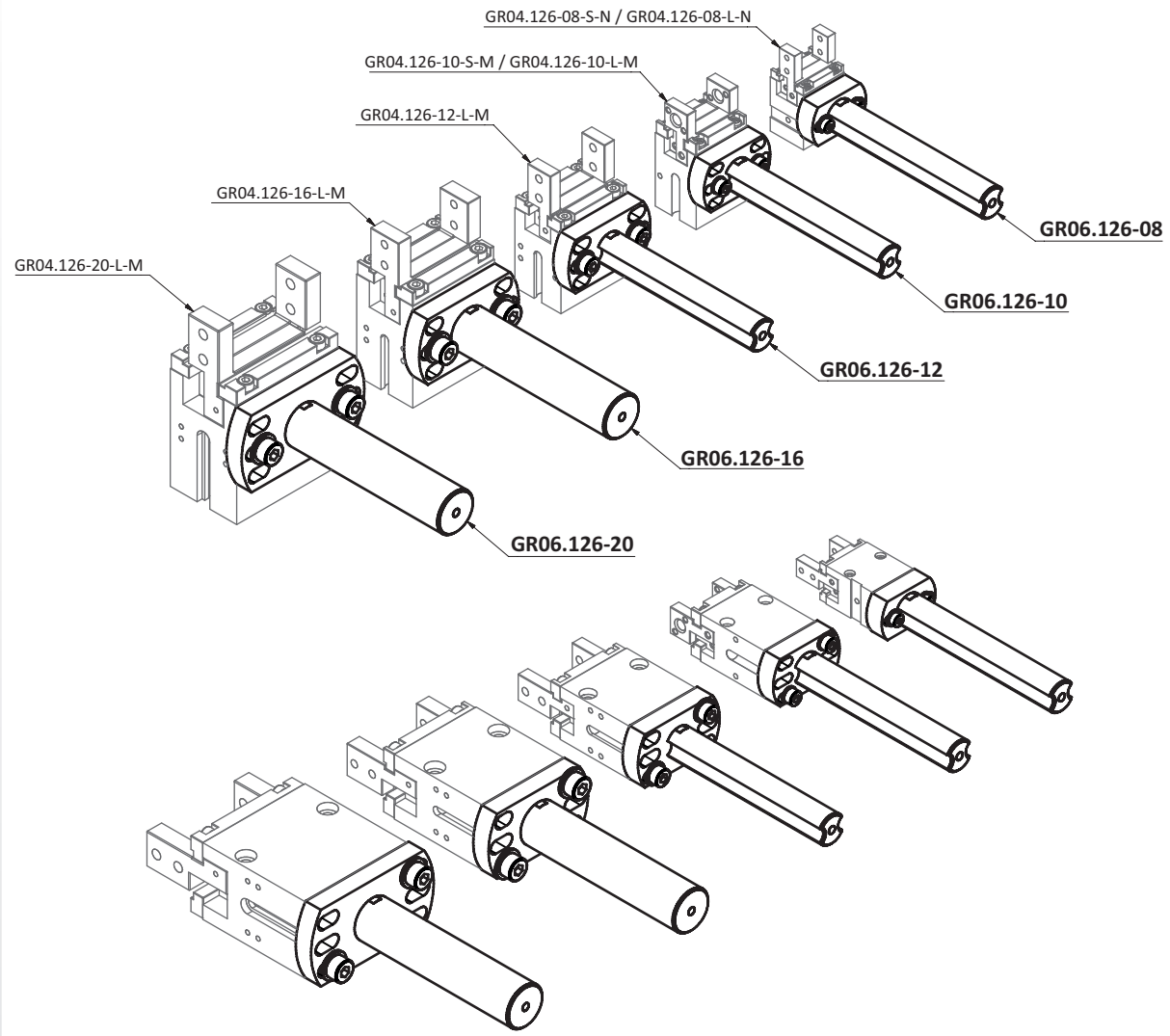



Dimensions

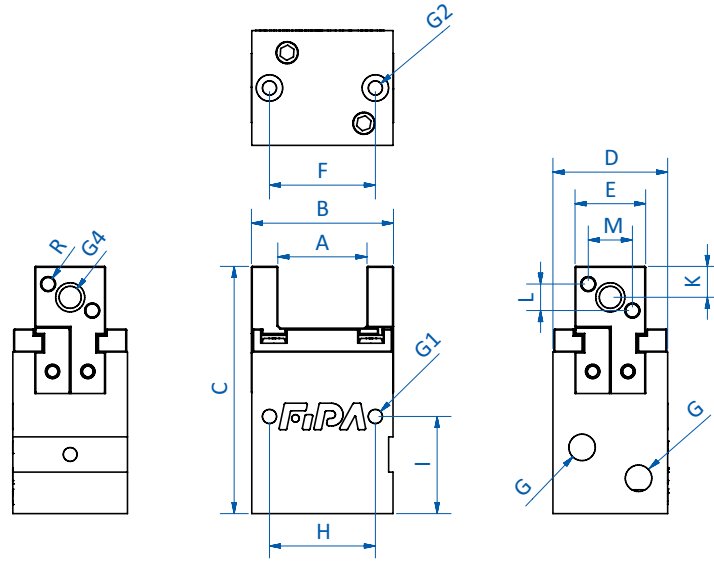

GR04.126-08-S-N

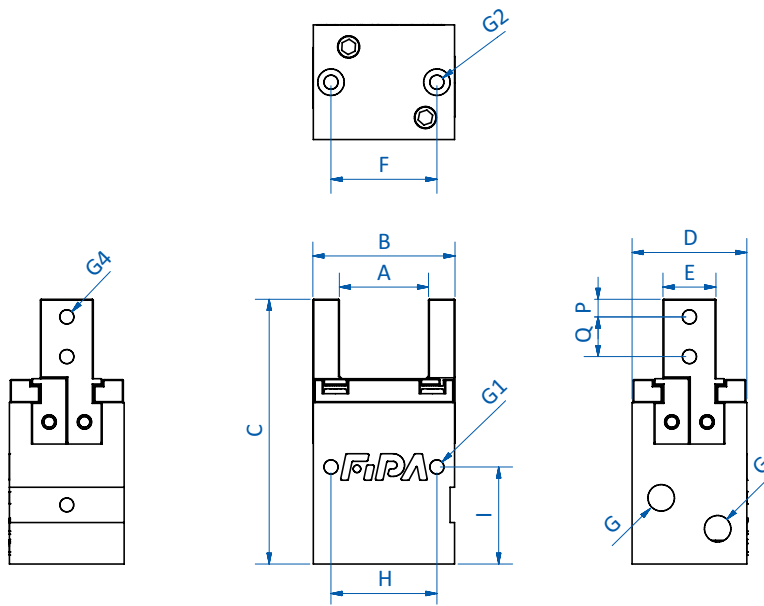

GR04.126-08-L-N

Continued on the next page →



### Dimensions

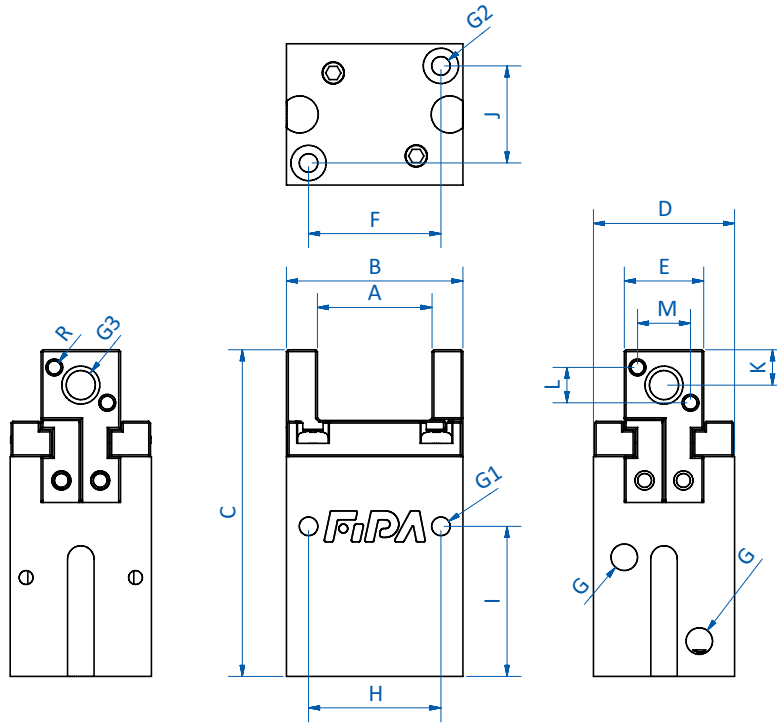

GR04.126-10-S-M

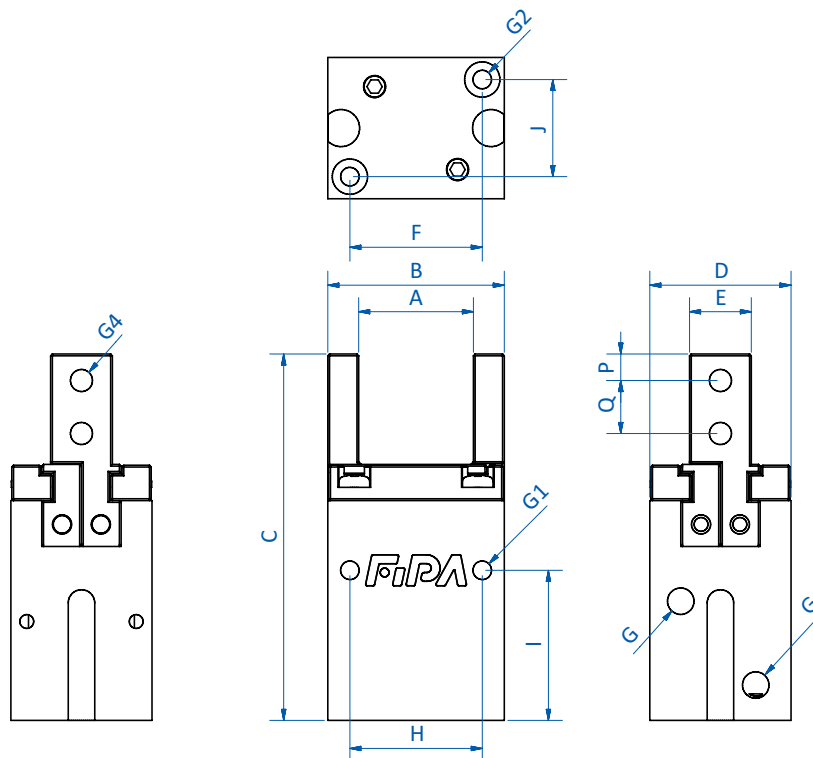

GR04.126-10-L-M | GR04.126-12-L-M | GR04.126-16-L-M | GR04.126-20-L-M



Item no.	GR04.126-08-S-N	GR04.126-08-L-N	GR04.126-10-S-M	GR04.126-10-L-M	GR04.126-12-L-M	GR04.126-16-L-M	GR04.126-20-L-M
A [mm]	10.1	10.1	13	13	17.2	22.2	28.2
B [mm]	16.1	16.1	20	20	25.2	32.2	40.2
C [mm]	28	30	37	41.5	44	53	62
D [mm]	13	13	16	16	18	22	26
E [mm]	8	6	9	7	9	11	12
F [mm]	12	12	15	15	20	25	32
G	M3	M3	M3	M3	M3	M5	M5
G1	M2	M2	M2.5	M2.5	M3	M4	M4
G2	M2	M2	M2.5	M2.5	M3	M4	M4
G3	M3	--	M4	--	--	--	--
G4	--	M2	--	M3	M3	M3	M4
H [mm]	12	12	15	15	20	25	32
I [mm]	11	11	17	17	19	22	25
J [mm]	--	--	11	11	12	15	16
K [mm]	3.5	--	4	--	--	--	--
L [mm]	3	--	4	--	--	--	--
M [mm]	5	--	6	--	--	--	--
P [mm]	--	2	--	3	3	3	4
Q [mm]	--	4.5	--	6	7	7	8.5
Ø R [mm]	1.5	--	1.5	--	--	--	--



### Parallel grippers – compact



#### Product notes

- > Double acting
- > Simple installation and adjustment of the sensors (not included in scope of delivery)
- > Large gripper stroke relative to gripper size
- > Robust design, long life and high reliability, maintenance-free
- > Compressed air connection - M5
- > Housing and jaws made of an anodized, high-strength aluminum alloy
- > Long lifetime due to special wear-resistant seals

#### Technical data

Item no.	GR04.151
Principle of operation	double-acting
Operating pressure [bar (psi)]	3 - 7 (43.5 - 101.5)
Piston diameter [mm]	16
Stroke per gripper jaw [mm]	4
Closing force at 6 bar (87 psi) [N]	102
Opening force at 6 bar (87 psi) [N]	113
Air consumption per cycle [cm <sup>3</sup> ]	1.76
Cycle time [Hz]	1.7
Max. operating temperature [°C (°F)]	-10 - 60 (14 - 140)
Weight [g]	49
Accessories	Air connection 30.200, Air connection 30.923, Mounting bracket: GR04.189, Sensor: GS04.007, Sensor: GS04.008

#### Application example

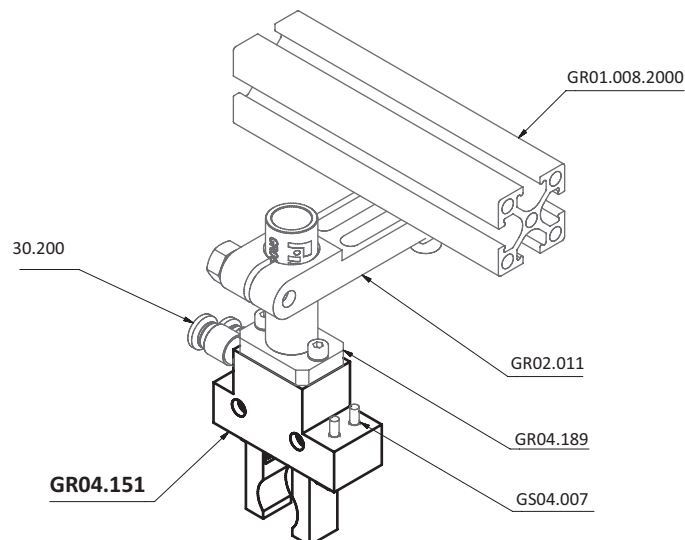



Dimensions

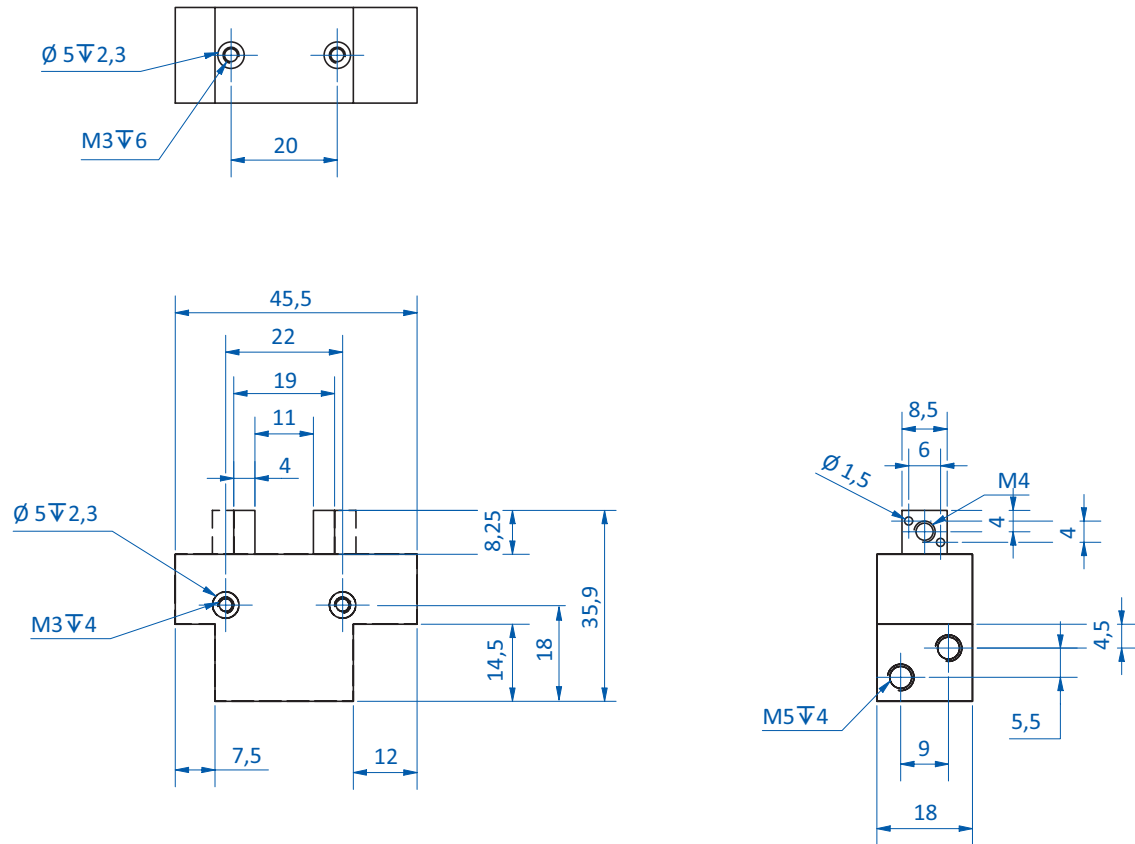



# Grippers | Parallel grippers

## 2-finger parallel grippers

### 2-finger parallel grippers



#### Product notes

- > Gripper with high gripping force
- > Double-acting for inside/outside gripping and short duty cycles
- > Single-acting: normally open (NO), compressed air for closing, opening via return spring
- > Body made of high-strength aluminum alloy, jaws are steel
- > Options
  - Base jaws for customization
  - Sensors for monitoring gripper action via piston position
- > Medium: filtered and oiled/unoiled air
- > PNP and NPN sensors:
  - C-slot (straight): GR04.198, GR04.198/NPN
  - C-slot (90° angle): GR04.202P, GR04.202N
  - C-slot (straight, short design): GR04.280P, GR04.280N
  - T-slot (straight): GR04.199, GR04.199/NPN
  - T-slot (straight, short design): GR04.203P, GR04.203N
- > Connector cable for sensors:
  - 20.503: 3-pole M8, cable straight, length 2,500 mm, open wire
  - 20.507: 3-pole M8, cable 90°, length 2,000 mm, open end
  - 20.570: 3-pole M8, length 1,500 mm, end with plug 3-pole M8

#### Technical data

Item no.	Principle of operation	Operating pressure [bar (psi)]	Piston diameter [mm]	Stroke per gripper jaw [mm]	Closing force at 6 bar (87 psi) [N]	Opening force at 6 bar (87 psi) [N]	Gripping point distance at 6 bar (87 psi) [mm]	Max. operating frequency [1/min]	Operating temperature [°C (°F)]	Weight [g]	Accessories
<b>GR04.122-10</b>	double-acting	2 - 7 (29 - 101.5)	10	2	15	22	20	100	0 - 60 (32 - 140)	60	Sensor: GR04.203N Sensor: GR04.203P Connecting cable: 20.503 Connecting cable: 20.507 Extension cable: 20.570 Mounting bracket: GR06.050
<b>GR04.122-10S</b>	single-acting	2 - 7 (29 - 101.5)	10	2	11	--	20	100	0 - 60 (32 - 140)	60	Sensor: GR04.203N Sensor: GR04.203P Connecting cable: 20.503 Connecting cable: 20.507 Extension cable: 20.570 Mounting bracket: GR06.050
<b>GR04.122-16</b>	double-acting	1.5 - 7 (21.8 - 101.5)	16	3	40	55	20	100	0 - 60 (32 - 140)	140	Sensor: GR04.198/NPN Sensor: GR04.198 Sensor: GR04.202N Sensor: GR04.202P Sensor: GR04.280N Sensor: GR04.280P Connecting cable: 20.503 Connecting cable: 20.507 Extension cable: 20.570 Mounting bracket: GR06.051





Technical data

Item no.	Principle of operation	Operating pressure [bar (psi)]	Piston diameter [mm]	Stroke per gripper jaw [mm]	Closing force at 6 bar (87 psi) [N]	Opening force at 6 bar (87 psi) [N]	Gripping point distance at 6 bar (87 psi) [mm]	Max. operating frequency [1/min]	Operating temperature [°C (°F)]	Weight [g]	Accessories
<b>GR04.122-16S</b>	single-acting	1.5 - 7 (21.8 - 101.5)	16	3	33	--	20	100	0 - 60 (32 - 140)	140	Sensor: GR04.198/NPN Sensor: GR04.198 Sensor: GR04.202N Sensor: GR04.202P Sensor: GR04.280N Sensor: GR04.280P Connecting cable: 20.503 Connecting cable: 20.507 Extension cable: 20.570 Mounting bracket: GR06.051
<b>GR04.122-20</b>	double-acting	1.5 - 7 (21.8 - 101.5)	20	5	49	76	40	100	0 - 60 (32 - 140)	270	Sensor: GR04.198/NPN Sensor: GR04.198 Sensor: GR04.202N Sensor: GR04.202P Sensor: GR04.280N Sensor: GR04.280P Connecting cable: 20.503 Connecting cable: 20.507 Extension cable: 20.570 Mounting bracket: GR06.052
<b>GR04.122-20S</b>	single-acting	1.5 - 7 (21.8 - 101.5)	20	5	40	--	40	100	0 - 60 (32 - 140)	270	Sensor: GR04.198/NPN Sensor: GR04.198 Sensor: GR04.202N Sensor: GR04.202P Sensor: GR04.280N Sensor: GR04.280P Connecting cable: 20.503 Connecting cable: 20.507 Extension cable: 20.570 Mounting bracket: GR06.052
<b>GR04.122-25</b>	double-acting	1.5 - 7 (21.8 - 101.5)	25	7	75	118	60	100	0 - 60 (32 - 140)	490	Sensor: GR04.198/NPN Sensor: GR04.198 Sensor: GR04.202N Sensor: GR04.202P Sensor: GR04.280N Sensor: GR04.280P Connecting cable: 20.503 Connecting cable: 20.507 Extension cable: 20.570 Mounting bracket: GR06.053
<b>GR04.122-25S</b>	single-acting	1.5 - 7 (21.8 - 101.5)	25	7	55	--	60	100	0 - 60 (32 - 140)	490	Sensor: GR04.198/NPN Sensor: GR04.198 Sensor: GR04.202N Sensor: GR04.202P Sensor: GR04.280N Sensor: GR04.280P Connecting cable: 20.503 Connecting cable: 20.507 Extension cable: 20.570 Mounting bracket: GR06.053
<b>GR04.122-32</b>	double-acting	1.5 - 7 (21.8 - 101.5)	32	11	179	230	100	60	0 - 60 (32 - 140)	810	Sensor: GR04.198/NPN Sensor: GR04.198 Sensor: GR04.202N Sensor: GR04.202P Sensor: GR04.280N Sensor: GR04.280P Connecting cable: 20.503 Connecting cable: 20.507 Extension cable: 20.570 Mounting bracket: GR06.054



# Grippers | Parallel grippers

## 2-finger parallel grippers

### Technical data

Item no.	Principle of operation	Operating pressure [bar (psi)]	Piston diameter [mm]	Stroke per gripper jaw [mm]	Closing force at 6 bar (87 psi) [N]	Opening force at 6 bar (87 psi) [N]	Gripping point distance at 6 bar (87 psi) [mm]	Max. operating frequency [1/min]	Operating temperature [°C (°F)]	Weight [g]	Accessories
<b>GR04.122-32S</b>	single-acting	1.5 - 7 (21.8 - 101.5)	32	11	152	--	100	60	0 - 60 (32 - 140)	810	Sensor: GR04.198/NPN Sensor: GR04.198 Sensor: GR04.202N Sensor: GR04.202P Sensor: GR04.280N Sensor: GR04.280P Connecting cable: 20.503 Connecting cable: 20.507 Extension cable: 20.570 Mounting bracket: GR06.054
<b>GR04.122-40</b>	double-acting	1.5 - 7 (21.8 - 101.5)	40	15	285	370	125	60	0 - 60 (32 - 140)	1,390	Sensor: GR04.198/NPN Sensor: GR04.198 Sensor: GR04.202N Sensor: GR04.202P Sensor: GR04.280N Sensor: GR04.280P Connecting cable: 20.503 Connecting cable: 20.507 Extension cable: 20.570 Mounting bracket: GR06.055
<b>GR04.122-40S</b>	single-acting	1.5 - 7 (21.8 - 101.5)	40	15	248	--	125	60	0 - 60 (32 - 140)	1,390	Sensor: GR04.198/NPN Sensor: GR04.198 Sensor: GR04.202N Sensor: GR04.202P Sensor: GR04.280N Sensor: GR04.280P Connecting cable: 20.503 Connecting cable: 20.507 Extension cable: 20.570 Mounting bracket: GR06.055

### Distance to gripping point (\* see diagrams)

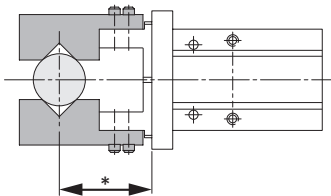



Dimensions

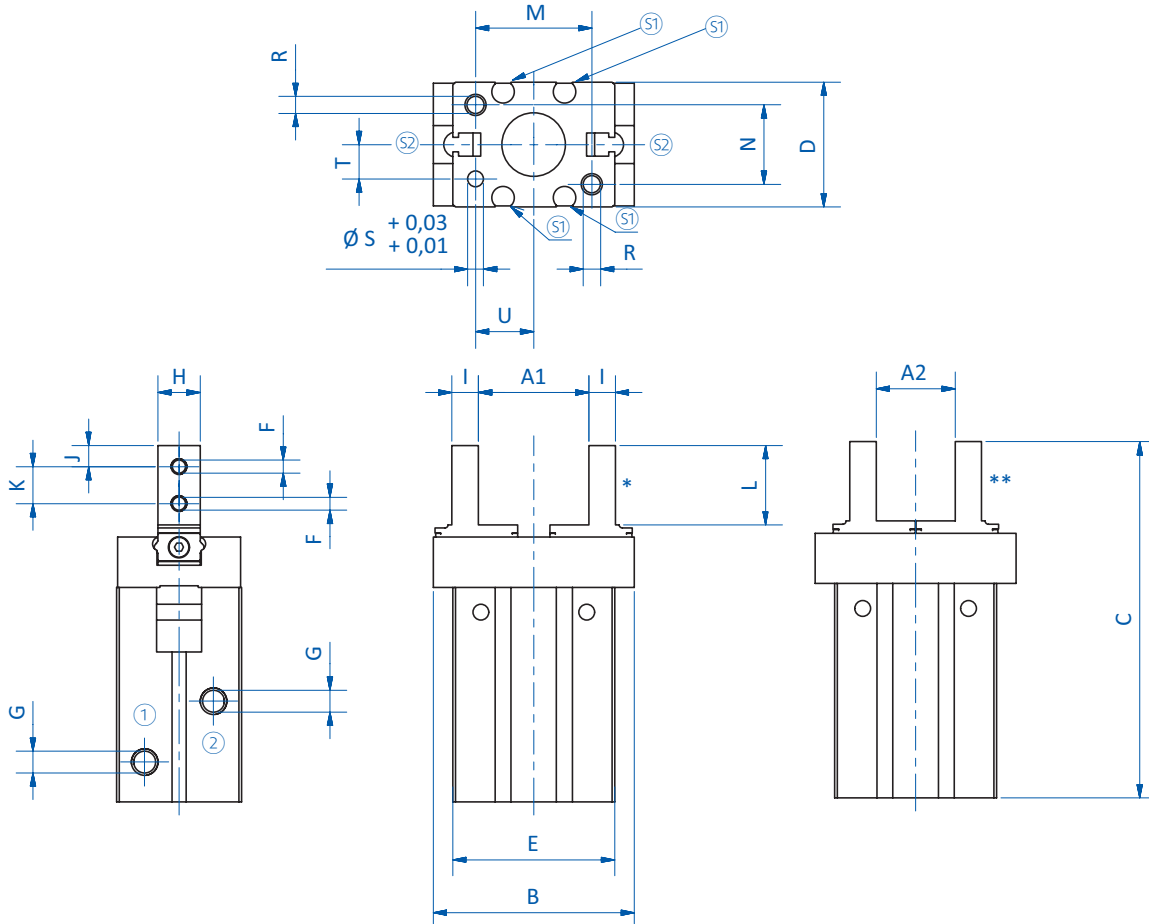

S1 = Sensor slot for GR04.202 and GR04.280 S2 = Sensor slot for GR04.203 1 = Compressed air supply (open) 2 = Compressed air supply (close)  
\* = Gripper jaw opened \*\* = Gripper jaw closed

Item no.	A1 [mm]	A2 [mm]	B [mm]	C [mm]	D [mm]	E [mm]	F	G	H [mm]	I [mm]	J [mm]	K [mm]	L [mm]	M [mm]	N [mm]	R	∅ S [mm]	T [mm]	U [mm]
GR04.122-10	15.2	11.2	29	57	16.4	23	M2,5	M3	5	4	3	5.7	12	18	12	M3	2	5.2	7.6
GR04.122-10S	15.2	11.2	29	57	16.4	23	M2,5	M3	5	4	3	5.7	12	18	12	M3	2	5.2	7.6
GR04.122-16	20.9	14.9	38	67.3	23.6	30.6	M3	M5	8	5	4	7	15	22	15	M4	3	6.5	11
GR04.122-16S	20.9	14.9	38	67.3	23.6	30.6	M3	M5	8	5	4	7	15	22	15	M4	3	6.5	11
GR04.122-20	26.3	16.3	50	84.8	27.6	42	M4	M5	10	8	5	9	20	32	18	M5	4	7.5	16.8
GR04.122-20S	26.3	16.3	50	84.8	27.6	42	M4	M5	10	8	5	9	20	32	18	M5	4	7.5	16.8
GR04.122-25	33.3	19.3	63	102.7	33.6	52	M5	M5	12	10	6	12	25	40	22	M6	4	10	21.8
GR04.122-25S	33.3	19.3	63	102.7	33.6	52	M5	M5	12	10	6	12	25	40	22	M6	4	10	21.8
GR04.122-32	48	26	97	113	40	60	M6	M5	15	12	7	14	29	46	26	M6	5	12	23
GR04.122-32S	48	26	97	113	40	60	M6	M5	15	12	7	14	29	46	26	M6	5	12	23
GR04.122-40	60	30	119	139	48	72	M8	M5	18	14	9	17	36	56	32	M8	5	14	29
GR04.122-40S	60	30	119	139	48	72	M8	M5	18	14	9	17	36	56	32	M8	5	14	29



# Grippers | Parallel grippers

## 2-finger parallel grippers

### Diagrams

> Closing force as a function of distance to gripping point and feed pressure

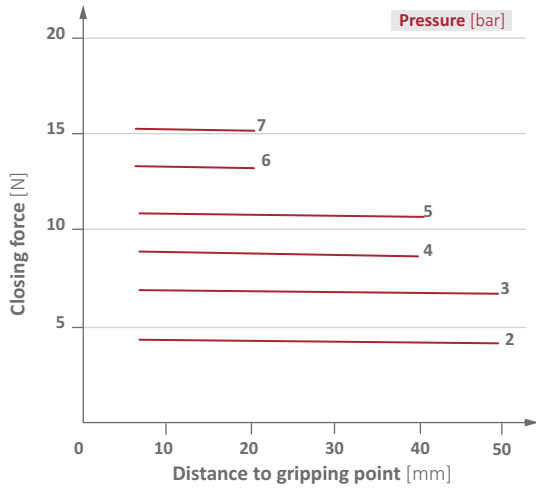

GR04.122-10

> Opening force as a function of distance to gripping point and feed pressure

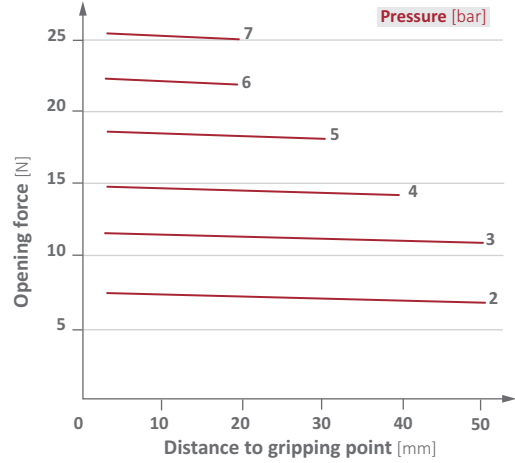

GR04.122-10

> Closing force as a function of distance to gripping point and feed pressure

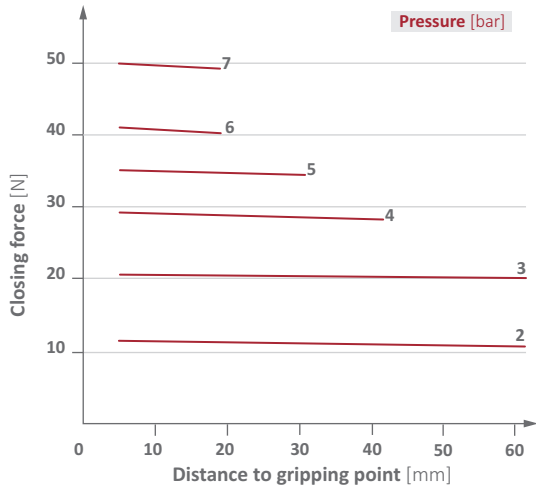

GR04.122-16

> Opening force as a function of distance to gripping point and feed pressure

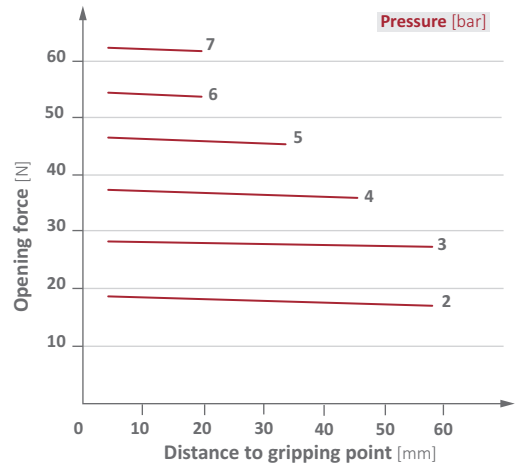

GR04.122-16

> Closing force as a function of distance to gripping point and feed pressure

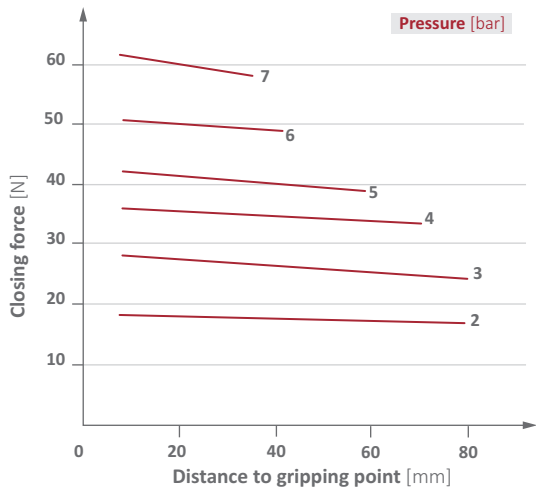

GR04.122-20

> Opening force as a function of distance to gripping point and feed pressure

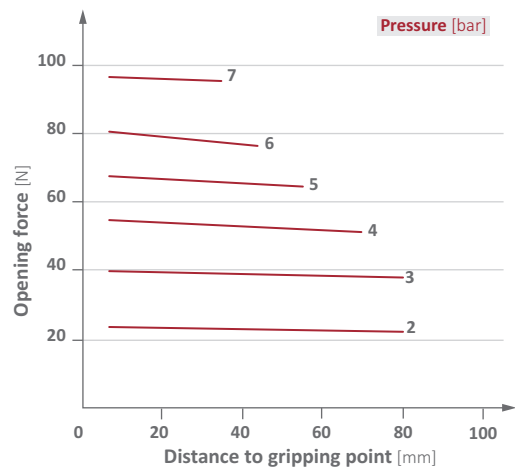

GR04.122-20



Diagrams

> Closing force as a function of distance to gripping point and feed pressure

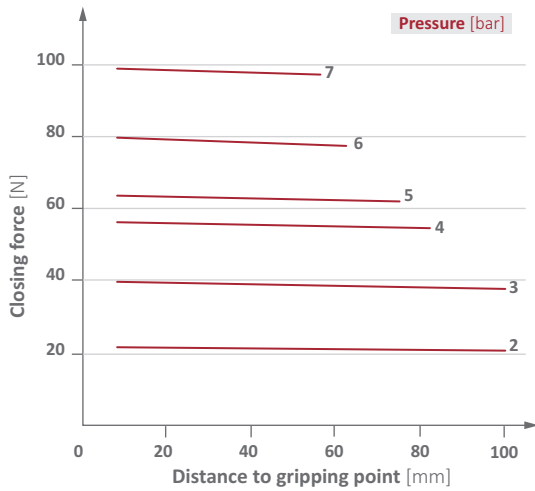

GR04.122-25

> Opening force as a function of distance to gripping point and feed pressure

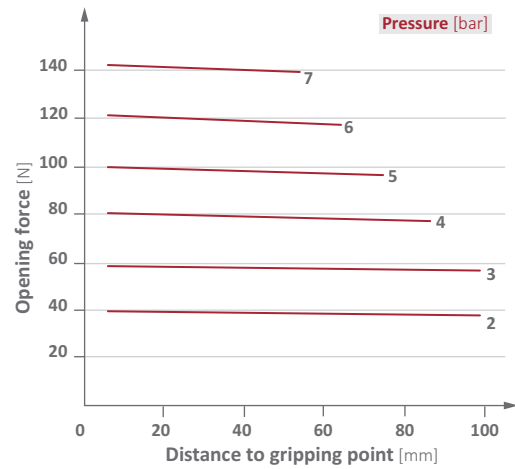

GR04.122-25

> Closing force as a function of distance to gripping point and feed pressure

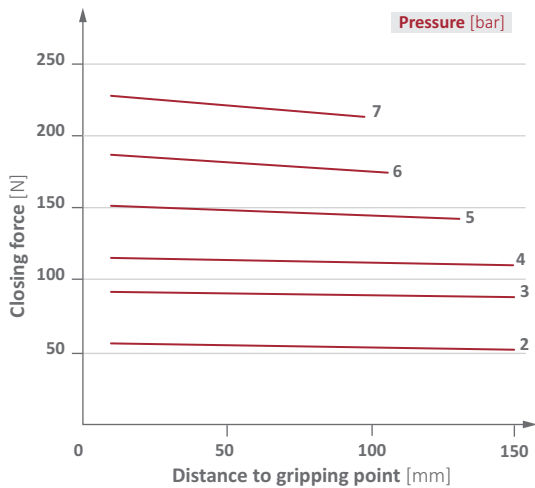

GR04.122-32

> Opening force as a function of distance to gripping point and feed pressure

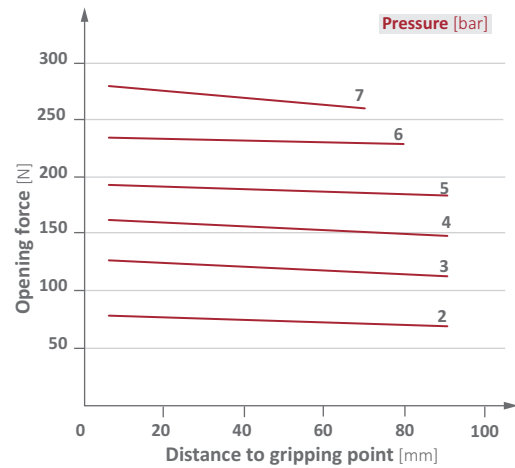

GR04.122-32

> Closing force as a function of distance to gripping point and feed pressure

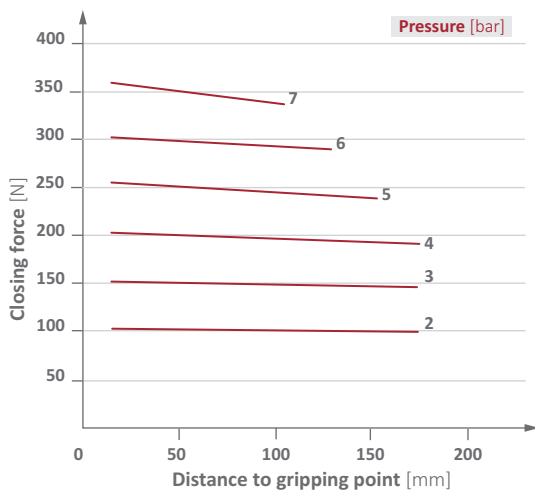

GR04.122-40

> Opening force as a function of distance to gripping point and feed pressure

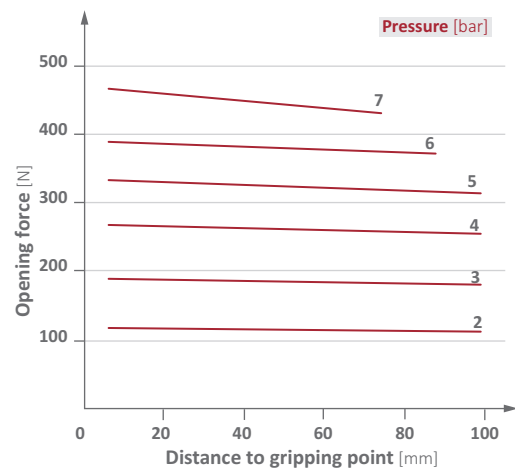

GR04.122-40



# Grippers | Parallel grippers

## Base jaws for parallel grippers

### Base jaws for parallel grippers



### Product notes

- > Base jaws aluminum (index -1) for customization
- > Base jaws steel (index -4) with HNBR pads enable soft gripping
- > Base jaws with index -4 come with HNBR pads
- > Scope of delivery: 2x base jaw including mounting screws

### Technical data

Item no.	Suitable for parallel grippers	Material	Weight [g]	Replacement parts
<b>GR04.122-10-1</b>	GR04.122-10, GR04.122-10S	Aluminum	20	--
<b>GR04.122-16-1</b>	GR04.122-16, GR04.122-16S	Aluminum	24	--
<b>GR04.122-20-1</b>	GR04.122-20, GR04.122-20S	Aluminum	37	--
<b>GR04.122-25-1</b>	GR04.122-25, GR04.122-25S	Aluminum	53	--
<b>GR04.122-32-1</b>	GR04.122-32, GR04.122-32S	Aluminum	106	--
<b>GR04.122-40-1</b>	GR04.122-40, GR04.122-40S	Aluminum	156	--
<b>GR04.122-10-4</b>	GR04.122-10, GR04.122-10S	Steel with HNBR pads	29	GR04.103-4 HNBR
<b>GR04.122-16-4</b>	GR04.122-16, GR04.122-16S	Steel with HNBR pads	49	GR04.103-4 HNBR
<b>GR04.122-20-4</b>	GR04.122-20, GR04.122-20S	Steel with HNBR pads	61	GR04.130C-4 HNBR
<b>GR04.122-25-4</b>	GR04.122-25, GR04.122-25S	Steel with HNBR pads	85	GR04.103-4 HNBR
<b>GR04.122-32-4</b>	GR04.122-32, GR04.122-32S	Steel with HNBR pads	136	GR04.103-4 HNBR
<b>GR04.122-40-4</b>	GR04.122-40, GR04.122-40S	Steel with HNBR pads	230	GR04.130C-4 HNBR

### Base jaws with HNBR pads

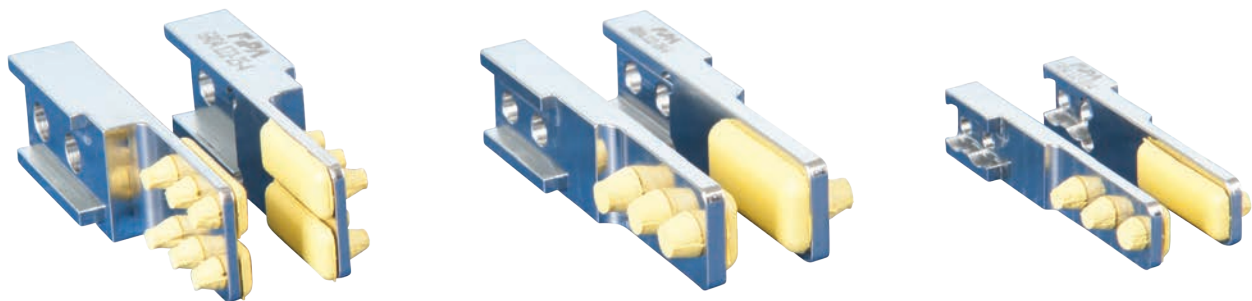



### Dimensions

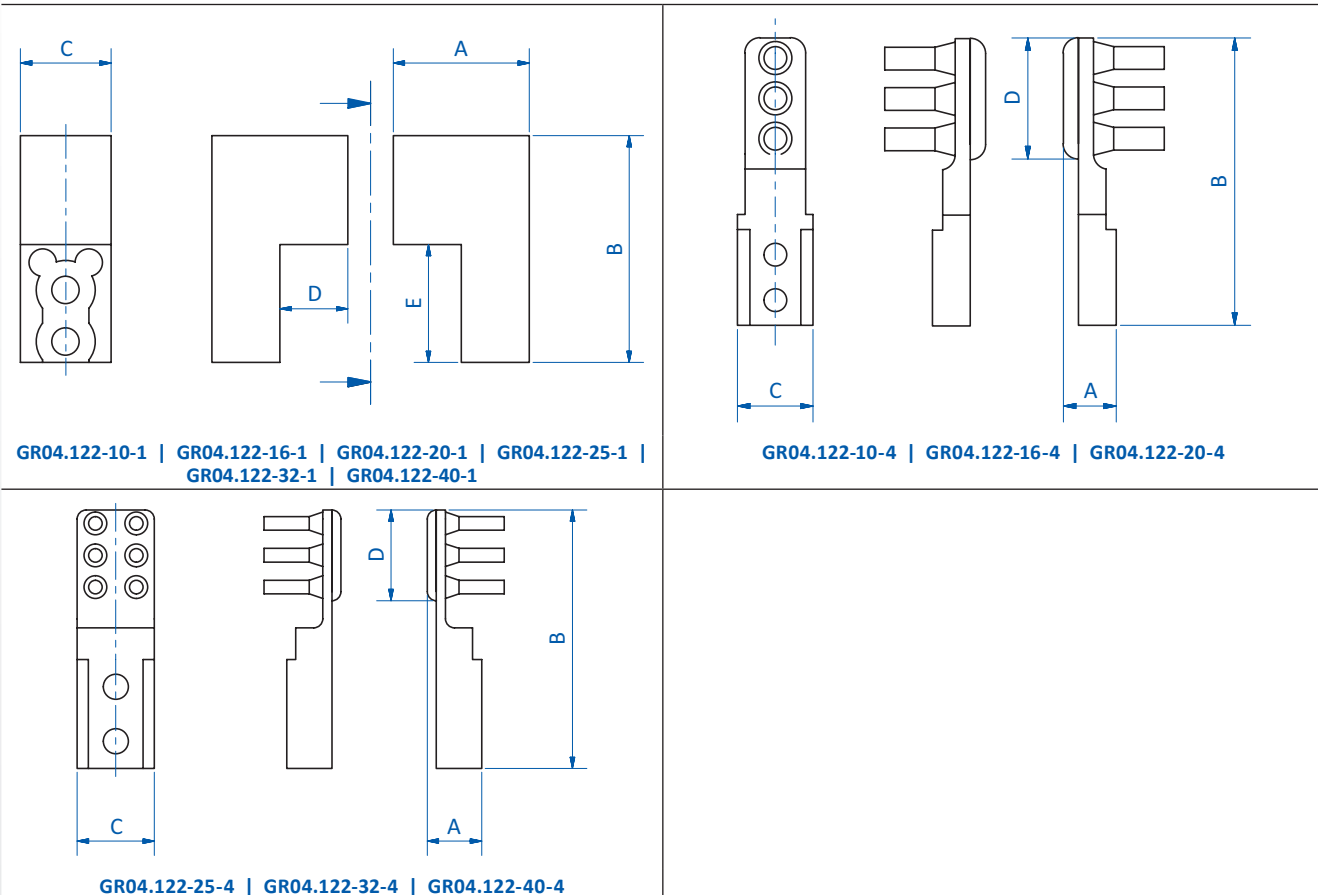

Item no.	A [mm]	B [mm]	C [mm]	D [mm]	E [mm]
GR04.122-10-1	15	25	10	7.5	13
GR04.122-16-1	17.9	28	13	10.4	16
GR04.122-20-1	21.5	33	15	14	21
GR04.122-25-1	25	38	17	17.5	26
GR04.122-32-1	36.4	42	20	22.9	30
GR04.122-40-1	40.4	49	23	26.9	37
GR04.122-10-4	7.5	45.2	10	20	--
GR04.122-16-4	9.5	57	13	20	--
GR04.122-20-4	10.5	57	15	24	--
GR04.122-25-4	12	57	17	20	--
GR04.122-32-4	15.2	57	20	20	--
GR04.122-40-4	17.3	64	24	24	--



# Grippers | Parallel grippers

Parallel grippers for large strokes – piston diameter 10 - 20 mm

## Parallel grippers for large strokes – piston diameter 10 - 20 mm

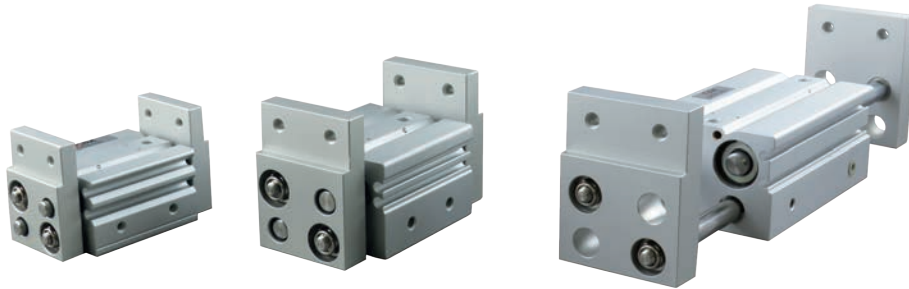

### Product notes

- > Gripper for large strokes for handling large parts
- > Double-acting for inside/outside gripping and short duty cycles
- > Body and jaws made of high-strength aluminum alloy
- > Sensors for monitoring gripper action via piston position optionally available
- > Medium: filtered and oiled/unoiled air
- > PNP and NPN sensors:
  - C-slot (straight) for sensors: GR04.198, GR04.198/NPN
  - C-slot (90° angle) for sensors: GR04.202P, GR04.202N
  - C-slot (straight, short design) for sensors: GR04.280P, GR04.280N

### Technical data

Item no.	GR04.510	GR04.510-1	GR04.510-2	GR04.516	GR04.516-1	GR04.516-2	GR04.520	GR04.520-1	GR04.520-2
Operating pressure [bar (psi)]	1.5 - 6 (21.8 - 87)	1.5 - 6 (21.8 - 87)	1.5 - 6 (21.8 - 87)	1 - 6 (14.5 - 87)	1 - 6 (14.5 - 87)	1 - 6 (14.5 - 87)	1 - 6 (14.5 - 87)	1 - 6 (14.5 - 87)	1 - 6 (14.5 - 87)
Piston diameter [mm]	10	10	10	16	16	16	20	20	20
Stroke per gripper jaw [mm]	10	20	30	15	30	40	20	40	50
Closing force at 6 bar (87 psi) [N]	22	22	22	60	60	60	100	100	100
Operating temperature [°C (°F)]	-5 - 70 (23 - 158)	-5 - 70 (23 - 158)	-5 - 70 (23 - 158)	-5 - 70 (23 - 158)	-5 - 70 (23 - 158)	-5 - 70 (23 - 158)	-5 - 70 (23 - 158)	-5 - 70 (23 - 158)	-5 - 70 (23 - 158)
Weight [g]	280	350	430	600	800	950	1,000	1,500	1,700
Suitable sensors	GR04.198 GR04.198/ NPN GR04.202P GR04.202N GR04.280P GR04.280N	GR04.198 GR04.198/ NPN GR04.202P GR04.202N GR04.280P GR04.280N	GR04.198 GR04.198/ NPN GR04.202P GR04.202N GR04.280P GR04.280N	GR04.198 GR04.198/ NPN GR04.202P GR04.202N GR04.280P GR04.280N	GR04.198 GR04.198/ NPN GR04.202P GR04.202N GR04.280P GR04.280N	GR04.198 GR04.198/ NPN GR04.202P GR04.202N GR04.280P GR04.280N	GR04.198 GR04.198/ NPN GR04.202P GR04.202N GR04.280P GR04.280N	GR04.198 GR04.198/ NPN GR04.202P GR04.202N GR04.280P GR04.280N	GR04.198 GR04.198/ NPN GR04.202P GR04.202N GR04.280P GR04.280N





Dimensions

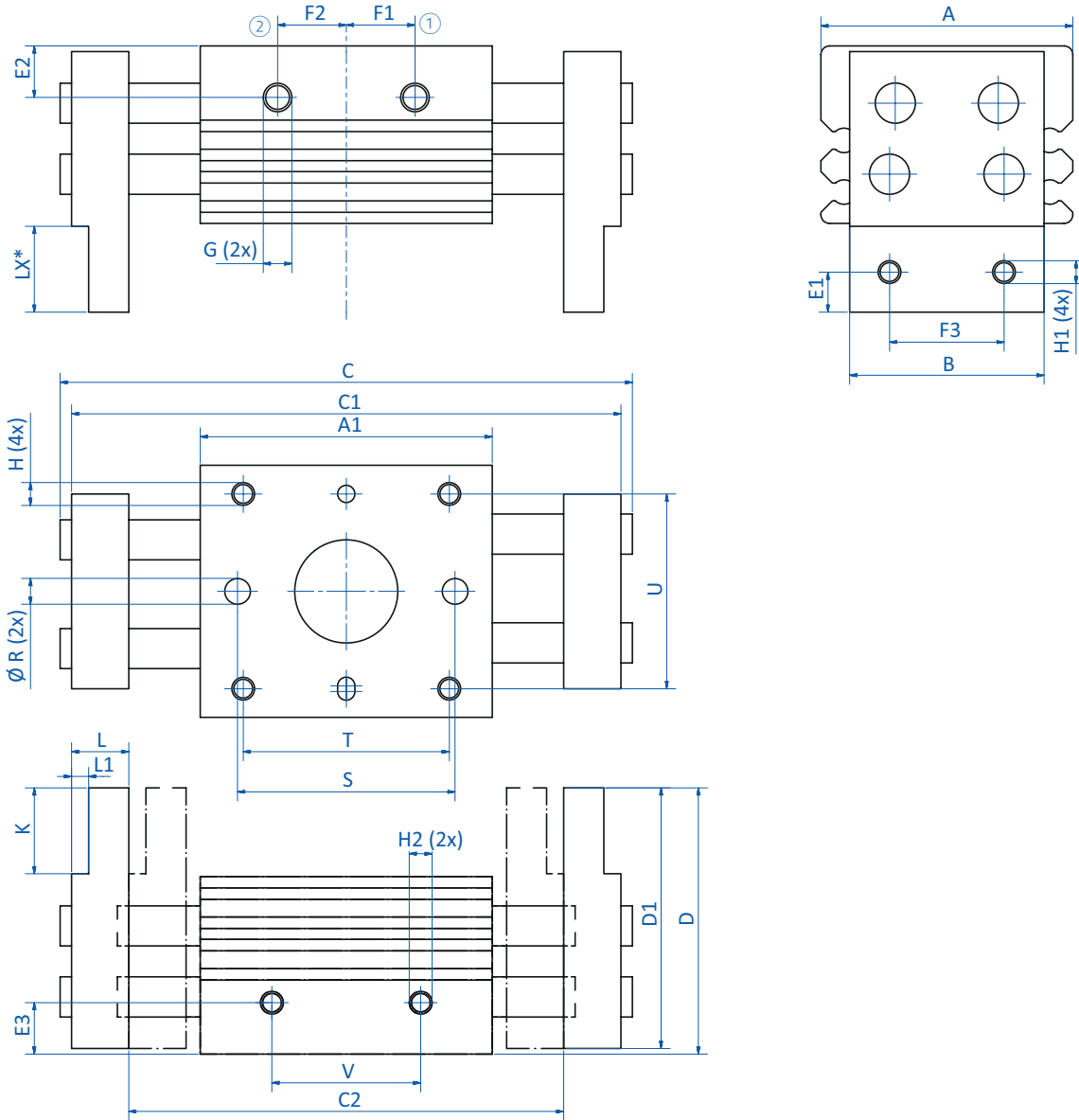

\* = LX: Distance gripper jaws – workpiece ① = Compressed air supply (open) ② = Compressed air supply (close)

Item no.	GR04.510	GR04.510-1	GR04.510-2	GR04.516	GR04.516-1	GR04.516-2	GR04.520	GR04.520-1	GR04.520-2
A [mm]	44	44	44	55	55	55	65	65	65
A1 [mm]	51	67	85	60	90	110	71	113	133
B [mm]	34	34	34	43	43	43	54	54	54
C [mm]	100	142	180	128	200	240	160	260	300
C1 [mm]	96	138	176	124	196	236	156	256	296
C2 [mm]	76	98	116	94	136	156	116	176	196
D [mm]	46	46	46	58	58	58	70	70	70
D1 [mm]	45.5	45.5	45.5	57.5	57.5	57.5	69	69	69
E1 [mm]	7	7	7	8	8	8	10	10	10
E2 [mm]	9	9	9	10	10	10	11	11	11

Continued on the next page



# Grippers | Parallel grippers

Parallel grippers for large strokes – piston diameter 10 - 20 mm

Item no.	GR04.510	GR04.510-1	GR04.510-2	GR04.516	GR04.516-1	GR04.516-2	GR04.520	GR04.520-1	GR04.520-2
E3 [mm]	9	9	9	10	10	10	11	11	11
F1 [mm]	11.5	19.5	28.5	13	25	35	16	34	44
F2 [mm]	11.5	19.5	28.5	13	25	35	16	34	44
F3 [mm]	20	20	20	25	25	25	30	30	30
G	M5	M5	M5	M5	M5	M5	M5	M5	M5
H	M4	M4	M4	M5	M5	M5	M6	M6	M6
H1	M4	M4	M4	M5	M5	M5	M6	M6	M6
H2	M4	M4	M4	M5	M5	M5	M6	M6	M6
K [mm]	15	15	15	19	19	19	24	24	24
L [mm]	10	10	10	13	13	13	17	17	17
L1 [mm]	3	3	3	4	4	4	4.5	4.5	4.5
Ø R [mm]	4.5	4.5	4.5	5.5	5.5	5.5	6.6	6.6	6.6
S [mm]	38	54	72	40	70	90	54	96	116
T [mm]	36	52	70	45	75	95	58	100	120
U [mm]	34	34	34	42	42	42	52	52	52
V [mm]	26	42	60	28	58	78	38	80	100

## Diagrams

> Gripping force piston diameter 10 mm – standard version

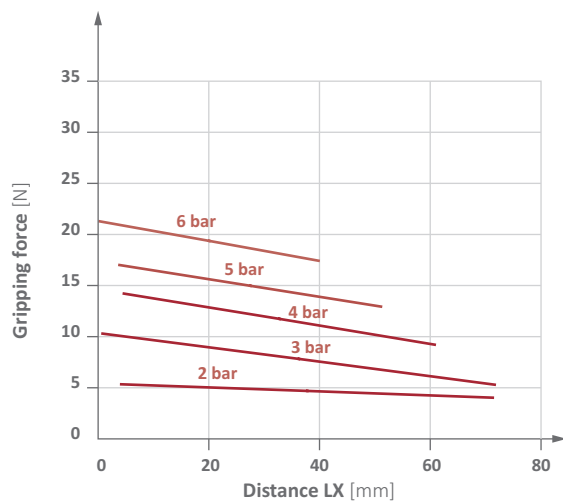

> Gripping force piston diameter 10 mm – versions 1 & 2

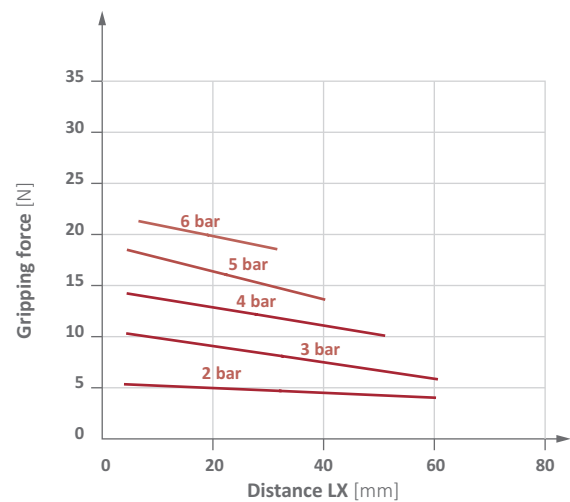

\* = LX distance to gripping point



### Diagrams

> Gripping force piston diameter 16 mm – standard version

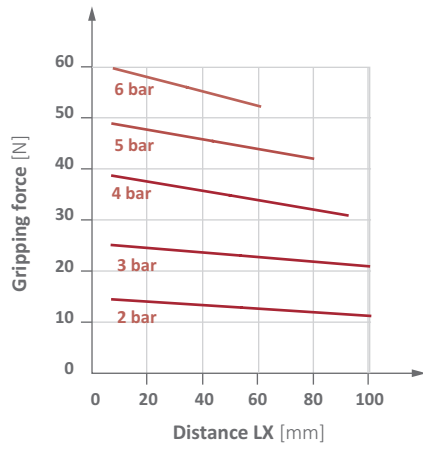

> Gripping force piston diameter 16 mm – versions 1 & 2

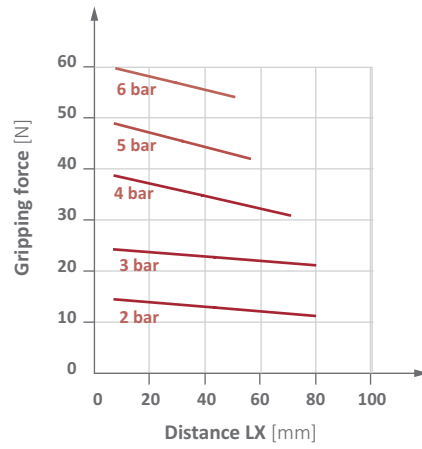

> Gripping force piston diameter 20 mm – standard version

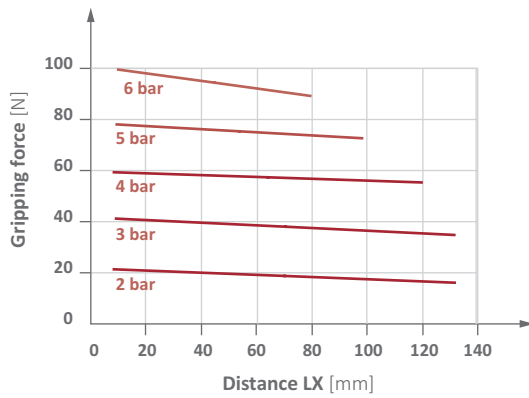

> Gripping force piston diameter 20 mm – versions 1 & 2

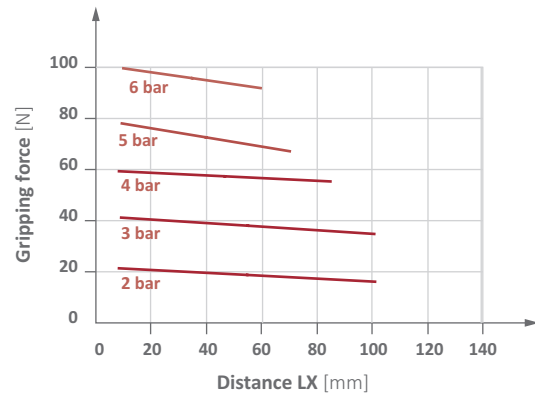

\* = LX distance to gripping point



# Grippers | Parallel grippers

Parallel grippers for large strokes – piston diameter 25 - 32 mm

## Parallel grippers for large strokes – piston diameter 25 - 32 mm

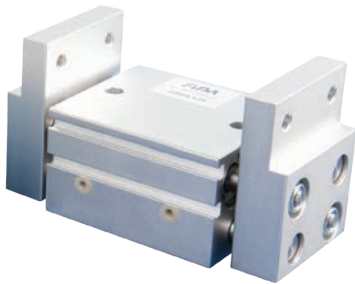

### Product notes

- > Grippers for large strokes for handling large parts
- > Double-acting for inside/outside gripping and short duty cycles
- > Body and jaws made of high-strength aluminum alloy
- > Sensors for monitoring gripper action via piston position optionally available
- > Medium: filtered and oiled/unoiled air
- > PNP and NPN sensors:
  - C-slot (straight) for sensors: GR04.198, GR04.198/NPN
  - C-slot (90° angle) for sensors: GR04.202P, GR04.202N
  - C-slot (straight, short design) for sensors: GR04.280P, GR04.280N

### Technical data

Item no.	GR04.525	GR04.525-1	GR04.525-2	GR04.532	GR04.532-1	GR04.532-2
Operating pressure [bar (psi)]	1 - 6 (14.5 - 87)	1 - 6 (14.5 - 87)	1 - 6 (14.5 - 87)	1 - 6 (14.5 - 87)	1 - 6 (14.5 - 87)	1 - 6 (14.5 - 87)
Piston diameter [mm]	25	25	25	32	32	32
Stroke per gripper jaw [mm]	25	50	60	35	60	80
Closing force at 6 bar (87 psi) [N]	160	160	160	300	300	300
Operating temperature [°C (°F)]	-5 - 70 (23 - 158)	-5 - 70 (23 - 158)	-5 - 70 (23 - 158)	-5 - 70 (23 - 158)	-5 - 70 (23 - 158)	-5 - 70 (23 - 158)
Weight [g]	1,700	2,500	2,800	2,900	3,800	4,700
Suitable sensors	GR04.198 GR04.198/NPN GR04.202P GR04.202N GR04.280P GR04.280N	GR04.198 GR04.198/NPN GR04.202P GR04.202N GR04.280P GR04.280N	GR04.198 GR04.198/NPN GR04.202P GR04.202N GR04.280P GR04.280N	GR04.198 GR04.198/NPN GR04.202P GR04.202N GR04.280P GR04.280N	GR04.198 GR04.198/NPN GR04.202P GR04.202N GR04.280P GR04.280N	GR04.198 GR04.198/NPN GR04.202P GR04.202N GR04.280P GR04.280N



## Dimensions

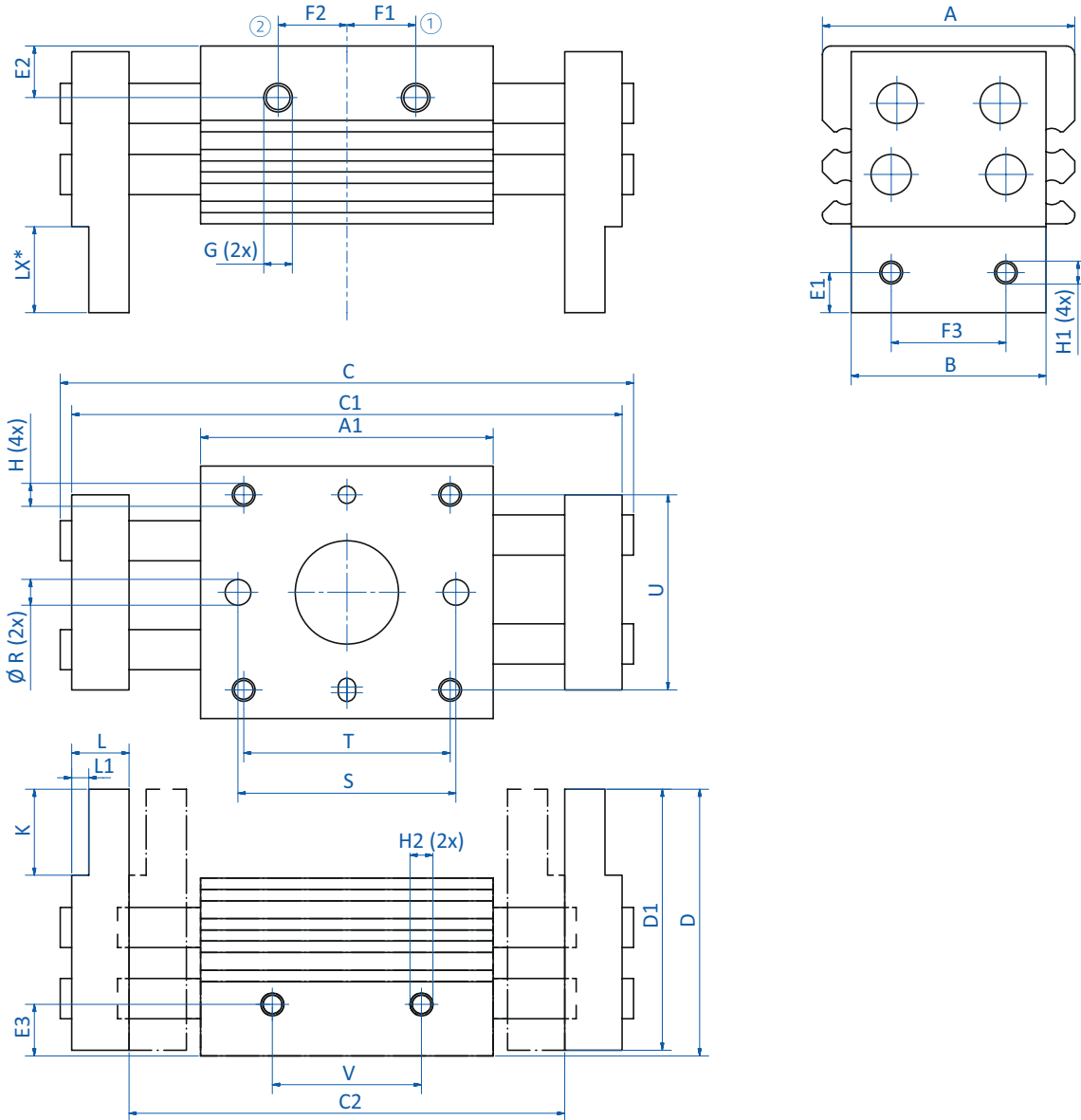

\* = LX: Distance gripper jaws – workpiece ① = Compressed air supply (open) ② = Compressed air supply (close)

Item no.	GR04.525	GR04.525-1	GR04.525-2	GR04.532	GR04.532-1	GR04.532-2
A [mm]	76	76	76	82	82	82
A1 [mm]	88	142	160	110	158	202
B [mm]	64	64	64	70	70	70
C [mm]	196	328	366	272	370	454
C1 [mm]	192	324	362	268	366	450
C2 [mm]	142	224	242	198	246	290
D [mm]	81	81	81	100	100	100
D1 [mm]	80	80	80	99	99	99
E1 [mm]	12	12	12	15	15	15
E2 [mm]	16	16	16	16	16	16

Continued on the next page →



# Grippers | Parallel grippers

Parallel grippers for large strokes – piston diameter 25 - 32 mm

Item no.	GR04.525	GR04.525-1	GR04.525-2	GR04.532	GR04.532-1	GR04.532-2
E3 [mm]	12.5	12.5	12.5	22	22	22
F1 [mm]	19	43	52	28	52	74
F2 [mm]	19	43	52	28	52	74
F3 [mm]	40	40	40	50	50	50
G	M5	M5	M5	Rc 1/8	Rc 1/8	Rc 1/8
H	M8	M8	M8	M8	M8	M8
H1	M8	M8	M8	M10	M10	M10
H2	M8	M8	M8	M8	M8	M8
K [mm]	29	29	29	32	32	32
L [mm]	21	21	21	24	24	24
L1 [mm]	7	7	7	9	9	9
Ø R [mm]	9	9	9	--	--	--
S [mm]	66	120	138	--	--	--
T [mm]	70	124	142	86	134	178
U [mm]	62	62	62	64	64	64
V [mm]	48	102	120	60	108	152

## Diagrams

> Gripping force piston diameter 25 mm – standard version

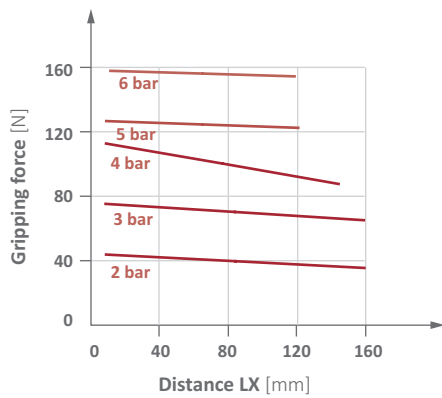

> Gripping force piston diameter 25 mm – versions 1 & 2

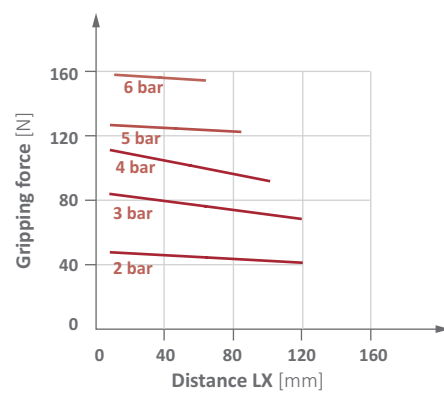

> Gripping force piston diameter 32 mm – standard version

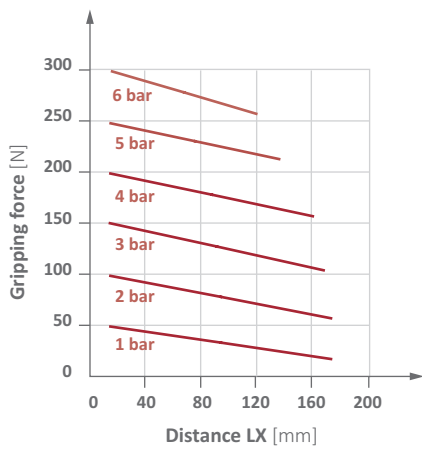

> Gripping force piston diameter 32 mm – versions 1 & 2

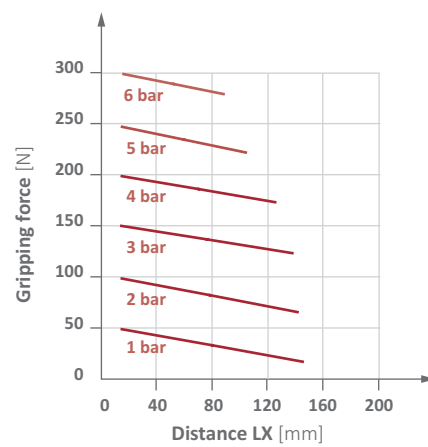

\* = LX distance to gripping point



### 2-finger angular grippers 40°



#### Product notes

- > Grippers for undercuts, clamping, mounting and pick & place applications
- > Double-acting: Inside/outside gripping and short duty cycles
- > Body made of high-strength aluminum alloy, jaws are steel
- > Sensors for monitoring gripper action via piston position optionally available
- > Medium: filtered and oiled/unoiled air
- > PNP and NPN sensors:
  - T-slot (straight) for sensors: GR04.203P, GR04.203N

#### Technical data

Item no.	GR04.123-10	GR04.123-16	GR04.123-20	GR04.123-25	GR04.123-32
Pressure range [bar (psi)]	1.5 - 7 (21.8 - 101.5)	1.5 - 7 (21.8 - 101.5)	1.5 - 7 (21.8 - 101.5)	1.5 - 7 (21.8 - 101.5)	1.5 - 7 (21.8 - 101.5)
Piston diameter [mm]	10	16	20	25	32
Angle stroke open [°]	-10	-10	-10	-10	-10
Angle stroke closed [°]	30	30	30	30	30
Max. closing torque at 6 bar [Ncm]	11	47	100	199	358
Max. opening torque at 6 bar [Ncm]	15	65	135	252	476
Max. operating frequency [1/min]	80	80	80	80	80
Operating temperature [°C (°F)]	0 - 60 (32 - 140)	0 - 60 (32 - 140)	0 - 60 (32 - 140)	0 - 60 (32 - 140)	0 - 60 (32 - 140)
Weight [g]	100	120	200	330	560
Accessories	Sensor: GR04.203N Sensor: GR04.203P Connecting cable: 20.503 Mounting bracket: GR06.050 Base jaw: GR04.123-10-1	Sensor: GR04.203N Sensor: GR04.203P Connecting cable: 20.503 Mounting bracket: GR06.051 Base jaw: GR04.123-16-1	Sensor: GR04.203N Sensor: GR04.203P Connecting cable: 20.503 Mounting bracket: GR06.052 Base jaw: GR04.123-20-1	Sensor: GR04.203N Sensor: GR04.203P Connecting cable: 20.503 Mounting bracket: GR06.053 Base jaw: GR04.123-25-1	Sensor: GR04.203N Sensor: GR04.203P Connecting cable: 20.503 Mounting bracket: GR06.054 Base jaw: GR04.123-32-1

Continued on the next page →



# Grippers | Angular grippers

2-finger angular grippers 40°

## Dimensions

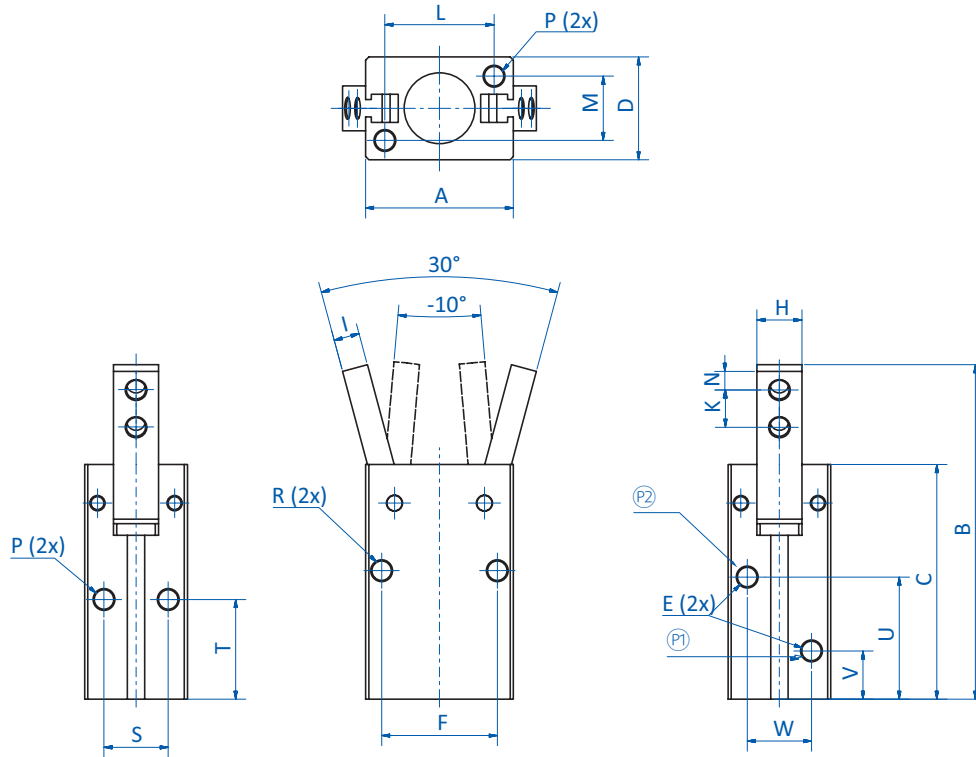

Ⓢ = Sensor slot for GR04.203   Ⓟ = Compressed air supply (open)   Ⓠ = Compressed air supply (close)

Item no.	GR04.123-10	GR04.123-16	GR04.123-20	GR04.123-25	GR04.123-32
A [mm]	23	34	45	52	60
B [mm]	52	64	75	89	100
C [mm]	36.5	45.5	53	61	68
D [mm]	16	22	26	32	40
E	M3	M5	M5	M5	M5
F [mm]	18	24	30	36	44
H [mm]	7	9	12	14	18
I [mm]	4	6	7	9	10
K [mm]	6	8	10	12	14
L [mm]	17	26	35	40	46
M [mm]	10	14	16	20	26
N [mm]	3	3	4	5	6
P	M3	M4	M5	M6	M6
R	M3	M4	M5	M6	M6
S [mm]	10	14	16	20	26
T [mm]	15.5	21	22	24.5	30
U [mm]	19	25.5	28	31	33.5
V [mm]	7.5	7.5	8	9	10
W [mm]	10	12	13	18	24





## Diagrams

> Length of gripping point (\* see diagrams)

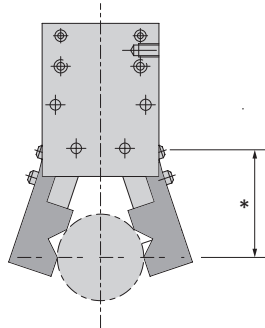

> Gripping force as a function of length of gripping point and feed pressure

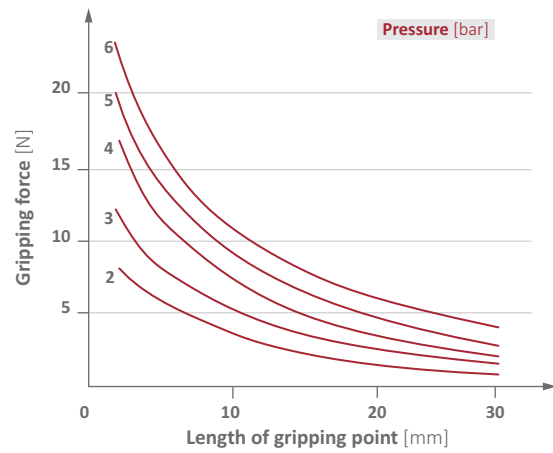

GR04.123-10 | GR04.123-16 | GR04.123-20 | GR04.123-25 | GR04.123-32

GR04.123-10

> Gripping force as a function of length of gripping point and feed pressure

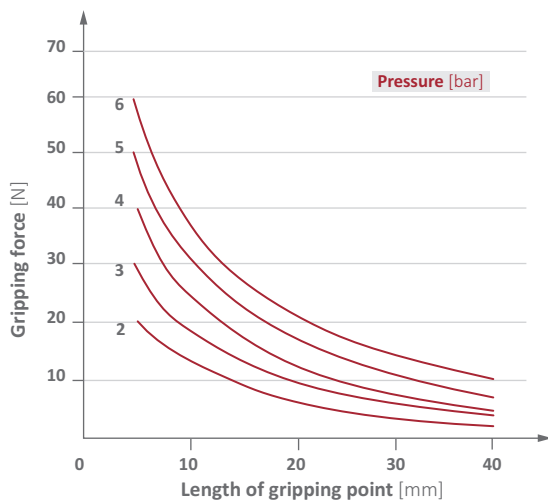

GR04.123-16

> Gripping force as a function of length of gripping point and feed pressure

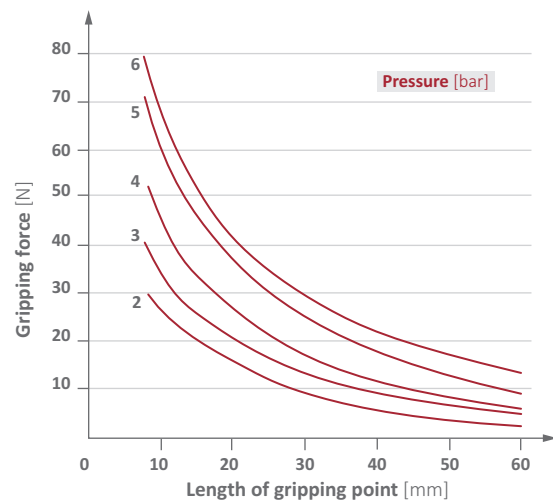

GR04.123-20

> Gripping force as a function of length of gripping point and feed pressure

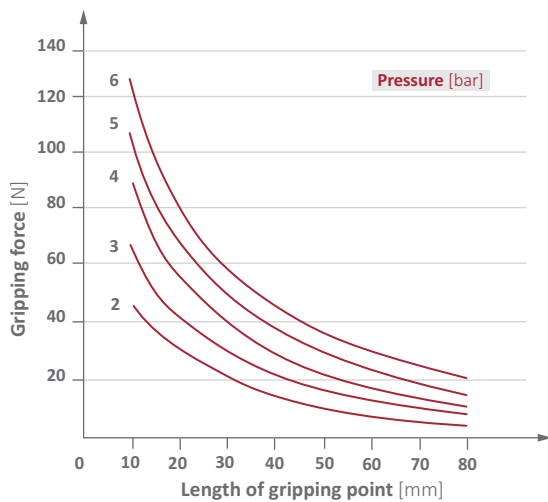

GR04.123-25

> Gripping force as a function of length of gripping point and feed pressure

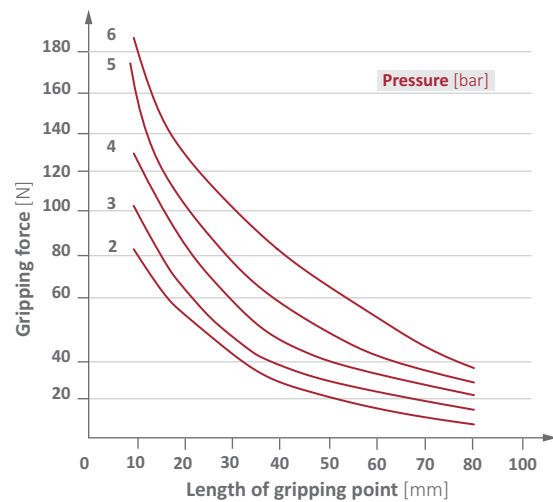

GR04.123-32



# Grippers | Angular grippers

Base jaws for angular grippers

## Base jaws for angular grippers

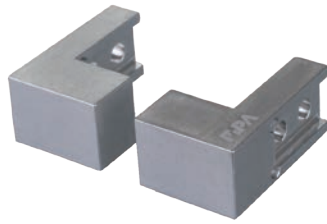

### Product notes

- > Aluminum blanks for customized jaws
- > Screws included in scope of delivery

### Technical data

Item no.	Suitable for angular grippers	Weight [g]
GR04.123-10-1	GR04.123-10	18
GR04.123-16-1	GR04.123-16	30
GR04.123-20-1	GR04.123-20	38
GR04.123-25-1	GR04.123-25	56
GR04.123-32-1	GR04.123-32	150

### Dimensions

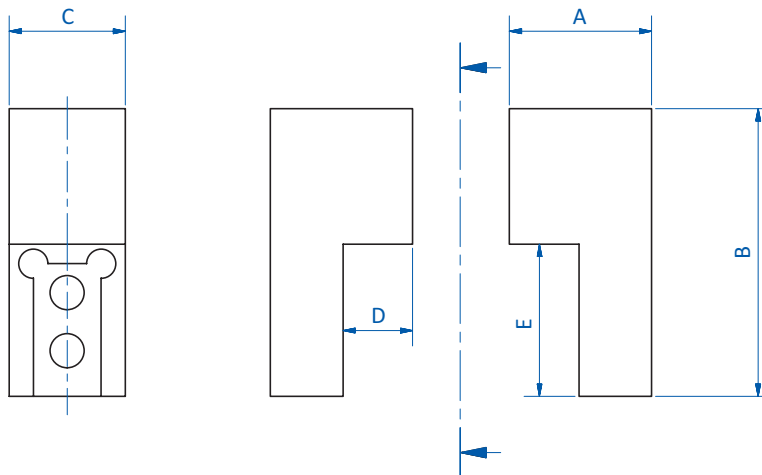

Item no.	A [mm]	B [mm]	C [mm]	D [mm]	E [mm]
GR04.123-10-1	14.7	29.7	12	7.2	15.7
GR04.123-16-1	20.5	31.5	14	13	17.5
GR04.123-20-1	24	36	17	16.5	21
GR04.123-25-1	29.8	40	19	20.8	26
GR04.123-32-1	33	44	23	24	29



## 2-finger angular gripper 180° – self-centering



### Product notes

- > High gripping force with high gripping precision
- > Gripping of objects located behind large undercuts; clamping and assembly of parts
- > Suitable for dusty environments due to dust protection seals
- > Double-acting, short duty cycles
- > Body made of high-strength aluminum alloy, jaws are steel
- > Versatile use with customized gripper jaws
- > Optional parts monitoring by detection of piston position
- > Medium: filtered and oiled/unoiled air
  
- > PNP and NPN sensors:
  - C-slot (90° angle): GR04.202P, GR04.202N
  - C-slot (straight, short design): GR04.280P, GR04.280N
- > Extension cable for sensors:
  - 20.503: 3-pole M8, length 2,500 mm, open wire
  - 20.570: 3-pole M8, length 1,500 mm, end with plug 3-pole M8

### Technical data

Item no.	GR04.121-10	GR04.121-16	GR04.121-20	GR04.121-25
Pressure range [bar (psi)]	1 - 6 (14.5 - 87)	1 - 6 (14.5 - 87)	1 - 6 (14.5 - 87)	1 - 6 (14.5 - 87)
Effective gripping torque [Nm]	0.16	0.54	1.1	2.28
Piston diameter [mm]	10	16	20	25
Angle stroke open [°]	180 - 182	180 - 182	180 - 182	180 - 182
Angle stroke closed [°]	-3	-3	-3	-3
Repeat accuracy [mm]	+/- 0.2	+/- 0.2	+/- 0.2	+/- 0.2
Max. operating frequency [1/min]	60	60	60	60
Operating temperature [°C (°F)]	-10 - 60 (14 - 140)	-10 - 60 (14 - 140)	-10 - 60 (14 - 140)	-10 - 60 (14 - 140)
Weight [g]	80	150	320	600
Accessories	Sensor: GR04.202N Sensor: GR04.202P Sensor: GR04.280N Sensor: GR04.280P Connecting cable: 20.503 Extension cable: 20.570	Sensor: GR04.202N Sensor: GR04.202P Sensor: GR04.280N Sensor: GR04.280P Connecting cable: 20.503 Extension cable: 20.570	Sensor: GR04.202N Sensor: GR04.202P Sensor: GR04.280N Sensor: GR04.280P Connecting cable: 20.503 Extension cable: 20.570	Sensor: GR04.202N Sensor: GR04.202P Sensor: GR04.280N Sensor: GR04.280P Connecting cable: 20.503 Extension cable: 20.570

Continued on the next page →



# Grippers | Angular grippers

2-finger angular gripper 180° – self-centering

## Dimensions

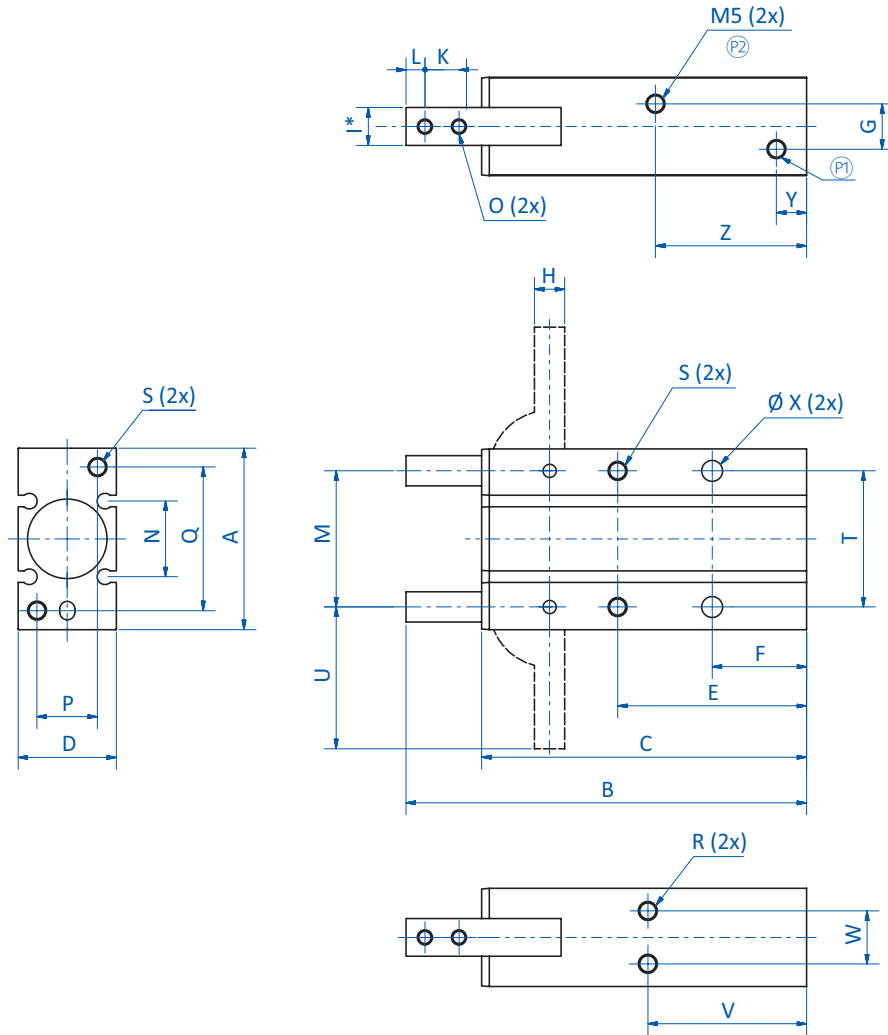

\* = Tolerance: -0.005 mm to -0.025 mm (P) = Compressed air supply (open) (P2) = Compressed air supply (close)

Item no.	GR04.121-10	GR04.121-16	GR04.121-20	GR04.121-25
A [mm]	30	38	48	58
B [mm]	71	84	106	131
C [mm]	58	69	86	107
D [mm]	15	20	26	30
E [mm]	35	41	50	60
F [mm]	18	20	25	30
G [mm]	3	8	12	14
H [mm]	4	5	8	10
I [mm]	6	8	10	12
K [mm]	6	7	9	12
L [mm]	3	4	5	6
M [mm]	22	28	36	45
N [mm]	13	18	20	24
O	M3	M3	M4	M5
P [mm]	9	12	16	18
Q [mm]	24	30	38	46



Item no.	GR04.121-10	GR04.121-16	GR04.121-20	GR04.121-25
R	M3x4	M4x5	M5x8	M6x10
S	M3x6	M4x8	M5x10	M6x12
T [mm]	24	30	36	42
U [mm]	23.5	28.5	37	45
V [mm]	30	33	42	50
W [mm]	9	12	14	16
Ø X [mm]	3.4	4.5	5.5	6.6
Y [mm]	7	7	8	8
Z [mm]	30	32	40	50

### Application examples

> Clamping

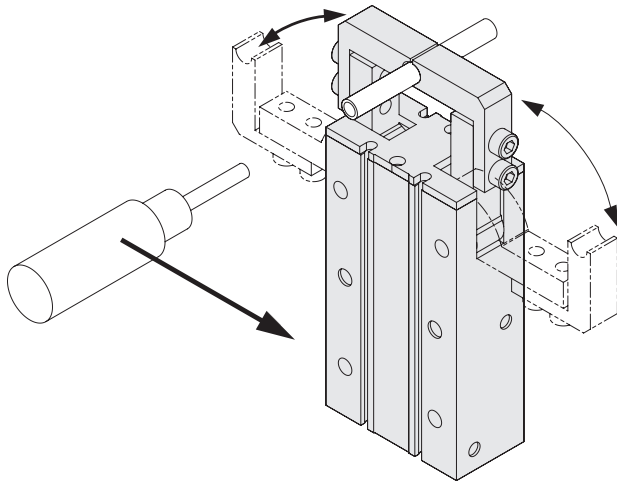

> Assembly

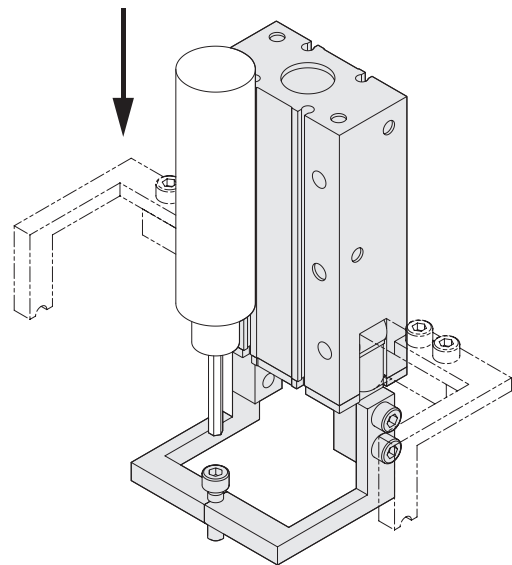



### Mounting brackets for parallel and angular grippers

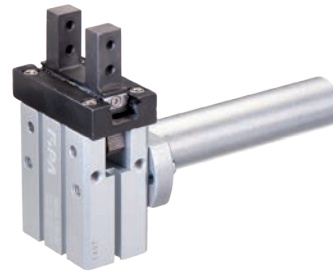
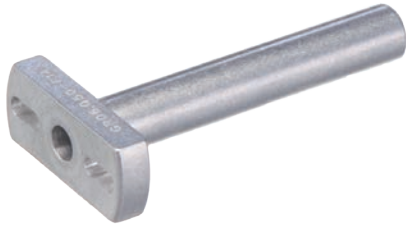

#### Product notes

- > Brackets for mounting parallel or angular grippers to extrusions
- > Compatible with many brands of grippers due to slotted mounting holes

#### Technical data

Item no.	Suitable for	Weight [g]
GR06.050	GR04.122-10, GR04.123-10	14
GR06.051	GR04.122-16, GR04.123-16	16
GR06.052	GR04.122-20, GR04.123-20	52
GR06.053	GR04.122-25, GR04.123-25	56
GR06.054	GR04.122-32, GR04.123-32	110
GR06.055	GR04.122-40	152

#### Dimensions

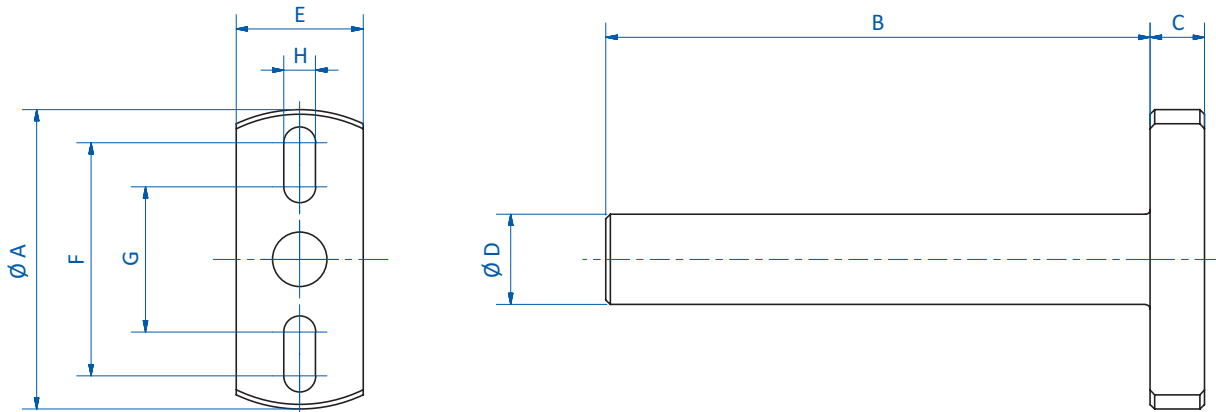

Item no.	Ø A [mm]	B [mm]	C [mm]	Ø D [mm]	E [mm]	F [mm]	G [mm]	H [mm]
GR06.050	33	60	6	10	14	25.7	16	3.5
GR06.051	39	60	6	14	18	32.5	22	4.5
GR06.052	49	90	8	20	24	40	30	5.5
GR06.053	59	90	8	20	24	50	32	6.5
GR06.054	64	120	8	30	32	53	44	6.5
GR06.055	79	120	10	30	40	64.5	56	8.5



3-finger grippers



Product notes

- > Grippers with high gripping force
- > Compact design
- > Double-acting for inside/outside gripping and short duty cycles
- > Body made of high-strength aluminum alloy, jaws are steel
- > Sensors for monitoring gripper action via piston position optionally available
- > Medium: filtered and oiled/unoiled air
- > PNP and NPN sensors:
  - C-slot (straight) for sensors: GR04.198, GR04.198/NPN
  - C-slot (90° angle) for sensors: GR04.202P, GR04.202N
  - C-slot (straight, short design) for sensors: GR04.280P, GR04.280N

Calculation of the inner gripping diameter:

- > Min.: dimensions W closed x 2
- > Max.: dimensions W opened x 2

Technical data

Item no.	GR04.125-16	GR04.125-25	GR04.125-32	GR04.125-40	GR04.125-50	GR04.125-60	GR04.125-80	
Operating pressure [bar (psi)]	2 - 6 (29 - 87)	2 - 6 (29 - 87)	1 - 6 (14.5 - 87)	1 - 6 (14.5 - 87)	1 - 6 (14.5 - 87)	1 - 6 (14.5 - 87)	1 - 6 (14.5 - 87)	
Piston diameter [mm]	16	25	32	40	50	63	80	
Stroke per gripper jaw [mm]	2	3	4	5	6	8	10	
Closing force at 6 bar (87 psi) [N]	19	58	98	165	247	425	650	
Opening force at 6 bar (87 psi) [N]	21	64	110	178	270	425	655	
Gripping point distance LX at 6 bar (87 psi) [mm]	The closing and opening force refers to a gripping distance of 10 mm	The closing and opening force refers to a gripping distance of 10 mm	The closing and opening force refers to a gripping distance of 10 mm	The closing and opening force refers to a gripping distance of 10 mm	The closing and opening force refers to a gripping distance of 10 mm	The closing and opening force refers to a gripping distance of 20 mm	The closing and opening force refers to a gripping distance of 20 mm	
Max. operating frequency [1/min]	120	120	60	60	60	60	30	
Operating temperature [°C (°F)]	-5 - 70 (23 - 158)	-5 - 70 (23 - 158)	-5 - 70 (23 - 158)	-5 - 70 (23 - 158)	-5 - 70 (23 - 158)	-5 - 70 (23 - 158)	-5 - 70 (23 - 158)	
Weight [g]	62	139	240	354	542	1,000	1,850	
Accessories	Sensor: GR04.198 GR04.198/NPN GR04.202P GR04.202N GR04.280P GR04.280N Mounting bracket: GR06.125-16	Sensor: GR04.198 GR04.198/NPN GR04.202P GR04.202N GR04.280P GR04.280N Mounting bracket: GR06.125-25	Sensor: GR04.198 GR04.198/NPN GR04.202P GR04.202N GR04.280P GR04.280N Mounting bracket: GR06.125-32	Sensor: GR04.198 GR04.198/NPN GR04.202P GR04.202N GR04.280P GR04.280N Mounting bracket: GR06.125-40	Sensor: GR04.198 GR04.198/NPN GR04.202P GR04.202N GR04.280P GR04.280N Mounting bracket: GR06.125-50	Sensor: GR04.198 GR04.198/NPN GR04.202P GR04.202N GR04.280P GR04.280N Mounting bracket: GR06.125-60	Sensor: GR04.198 GR04.198/NPN GR04.202P GR04.202N GR04.280P GR04.280N Mounting bracket: GR06.125-80	Sensor: GR04.198 GR04.198/NPN GR04.202P GR04.202N GR04.280P GR04.280N Mounting bracket: GR06.125-80

Continued on the next page →



# Grippers | 3-finger grippers

## 3-finger grippers

### Dimensions

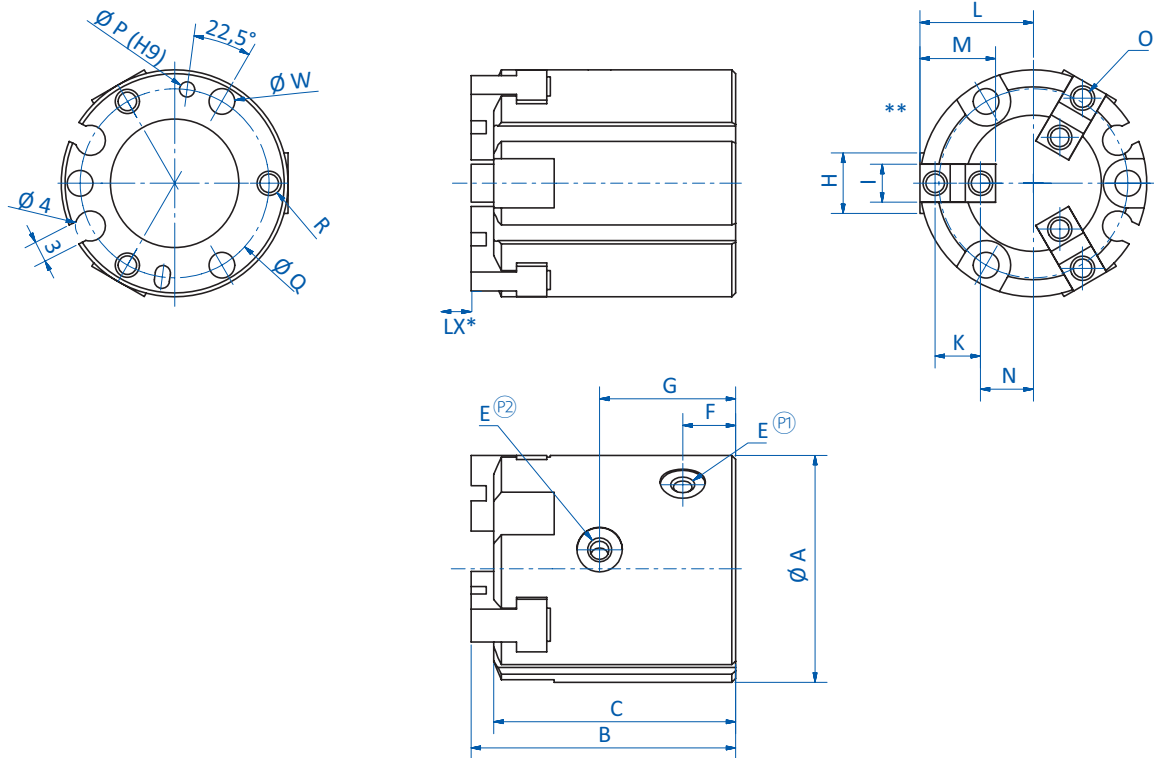

\* = LX: Distance between the gripper jaw and the gripper (see gripper force diagrams) P<sup>1</sup> = Compressed air supply (open) P<sup>2</sup> = Compressed air supply (close) \*\* = Gripper jaw closed

Item no.	GR04.125-16	GR04.125-25	GR04.125-32	GR04.125-40	GR04.125-50	GR04.125-60	GR04.125-80
Ø A [mm]	30	42	52	62	70	86	106
B [mm]	35	40	44	47	55	66	82
C [mm]	32	37	41	44	52	62	77
E	M3x0.5x11	M5x0.8x15	M5x0,8	M5x0,8	M5x0,8	M5x0,8	G1/8
F [mm]	7	7	8	8	9	12	13.5
G [mm]	18	22	24	26	29	34	40.5
H [mm]	8	12	14	16	18	24	28
I [mm]	5	6	8	8	10	12	14
K [mm]	6	8	11	12	14	17	20
L open [mm]	17	24	32	35	41	51	63.3
L closed [mm]	15	21	28	31	35	43	53.3
M [mm]	10	14	20	21	24	28	32
N open [mm]	9	13	16.5	19	21	28.5	37.3
N closed [mm]	7	9	12.5	14	15	20.5	27.3
O	M3x0.5x5	M3x0.5x5	M4x0.7x8	M4x0.7x8	M5x0.8x10	M5x0.8x10	M6x1x12
Ø P	2x2	3x3	3x3	4x4	4x4	5x5	5x5
Ø Q [mm]	25	34	44	53	62	76	95
R	M3x0.5x4	M4x0.5x7	M4x0.7x6	M5x0.8x0.7	M5x0.8x10	M6x1x9	M6x1x12
Ø W [mm]	3.4	4.5	4.5	5.5	5.5	6.5	6.5





Diagrams

> Closing force piston diameter 16 mm

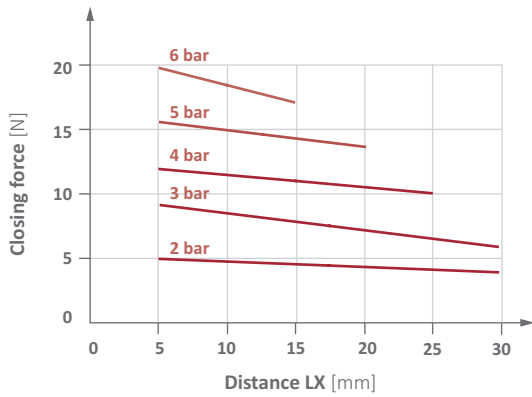

> Closing force piston diameter 25 mm

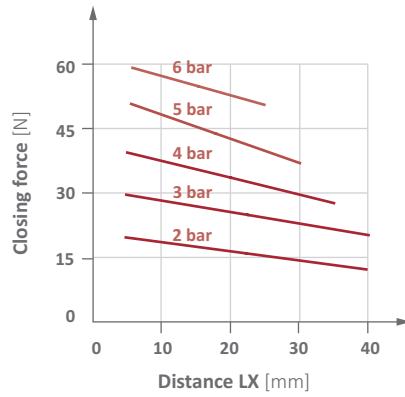

> Closing force piston diameter 32 mm

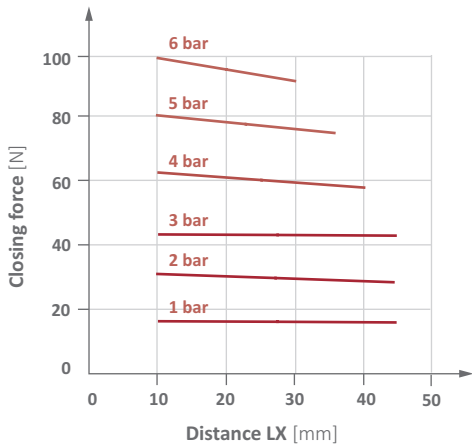

> Closing force piston diameter 40 mm

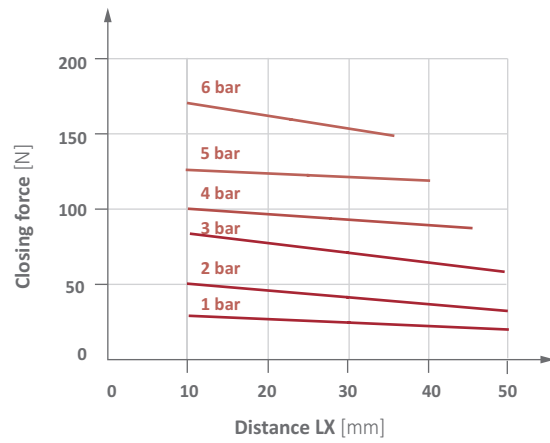

> Closing force piston diameter 50 mm

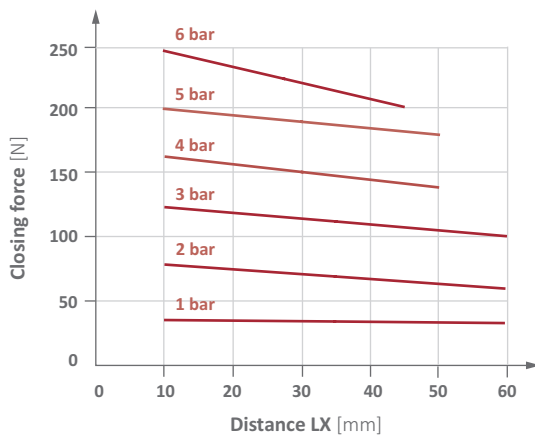

> Closing force piston diameter 63 mm

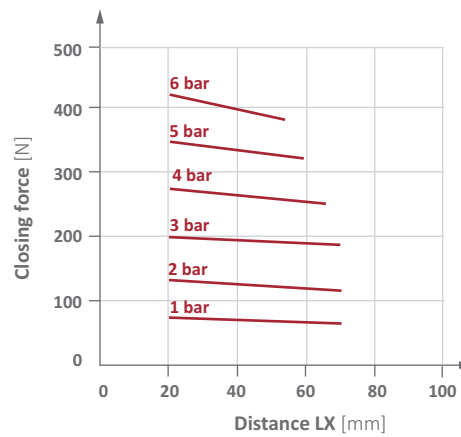

\* = LX distance to gripping point

Continued on the next page →



# Grippers | 3-finger grippers

## 3-finger grippers

### Diagrams

> Closing force piston diameter 80 mm

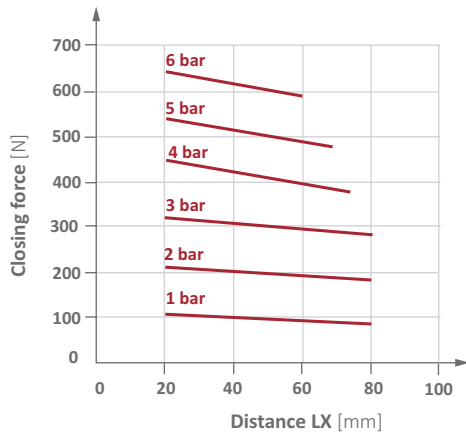

\* = LX distance to gripping point



### Mounting brackets for 3-finger grippers

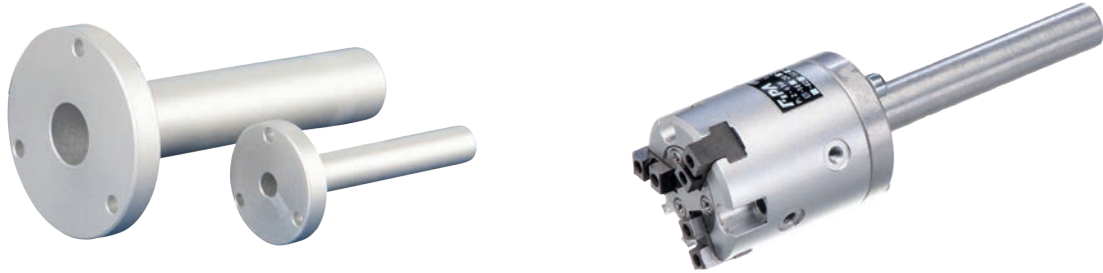

#### Product notes

> Brackets for mounting 3-finger parallel grippers to extrusions

#### Technical data

Item no.	Suitable for	Weight [g]
GR06.125-16	GR04.125-16L	18
GR06.125-25	GR04.125-25L	34
GR06.125-32	GR04.125-32L	74
GR06.125-40	GR04.125-40L	102
GR06.125-50	GR04.125-50L	232
GR06.125-60	GR04.125-60L	216

#### Dimensions

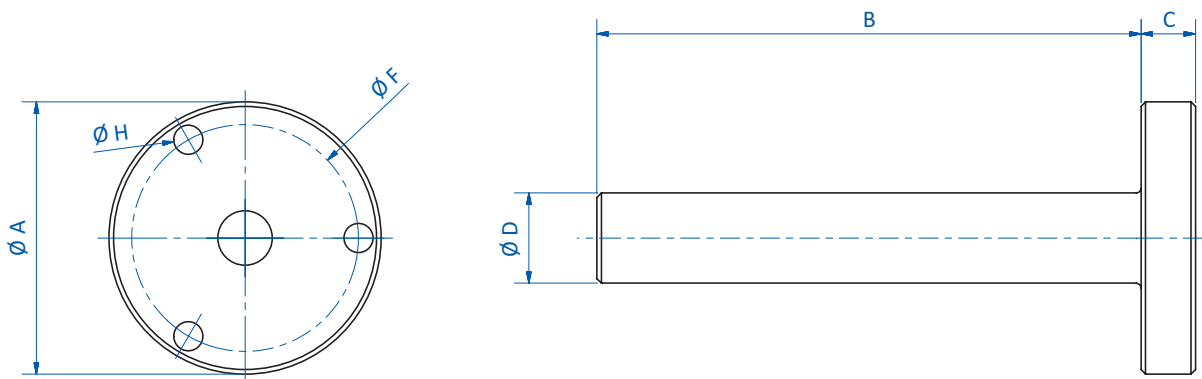

Item no.	$\varnothing A$ [mm]	B [mm]	C [mm]	$\varnothing D$ [mm]	$\varnothing F$ [mm]	$\varnothing H$ [mm]
GR06.125-16	30	60	6	10	25	3.2
GR06.125-25	42	90	6	14	34	4.2
GR06.125-32	52	90	8	20	44	4.2
GR06.125-40	62	120	8	20	53	5.3
GR06.125-50	70	150	8	30	62	5.3
GR06.125-60	86	150	8	30	76	6.3



### Elastomer pads



#### Product notes

- > Multi-purpose HNBR and silicone pads
- > Soft touch for handling sensitive product
- > HNBR flocked for highest demands on impression-free gripping
- > Easy to adapt to parallel, angular, or sprue grippers (e.g. GR04.130U) using machined or 3D printed jaws – just incorporate the bore pattern provided

#### Technical data

Item no.	Design	Size [mm]	Material
GR04.034-HNBR	Round	Ø 11	HNBR
GR04.044-HNBR	Round	Ø 17	HNBR
GR04.080-11H	Rectangle	13.5x3	HNBR
GR04.080-11S	Rectangle	13.5x3	Silicone (FDA compliant)
GR04.090-4	Rectangle	18x4	HNBR
GR04.090-4SI	Rectangle	18x4	Silicone (FDA compliant)
GR04.103-4 HNBR	Rectangle	20x8	HNBR
GR04.103-HNBR-80SH	Rectangle	20x8	HNBR 80° Shore
GR04.103-4 HNBR-F	Rectangle	20x8	HNBR, flocked
GR04.024-HNBR	Rectangle	20x15	HNBR
GR04.130C-4 HNBR	Rectangle	24x12	HNBR
GR04.130C-4 HNBR-F	Rectangle	24x12	HNBR, flocked
GR04.042-HNBR	Rectangle	30x20	HNBR



Application example

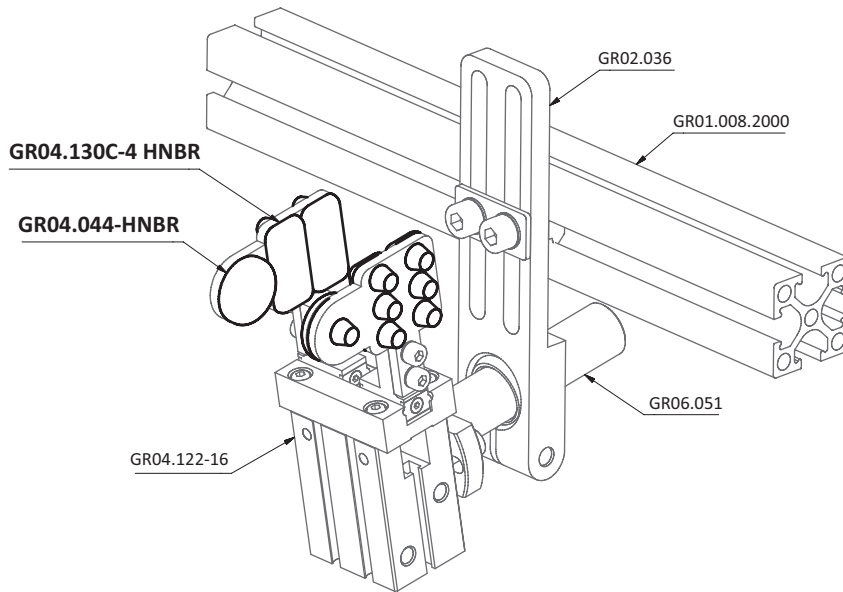

Dimensions



GR04.034-HNBR

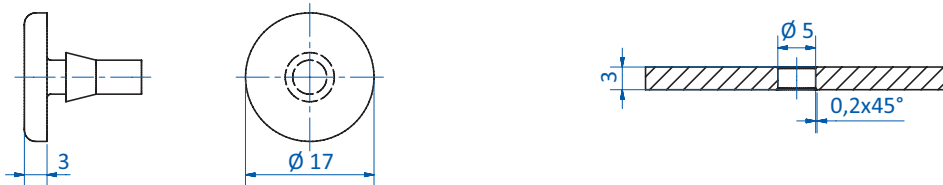

GR04.044-HNBR

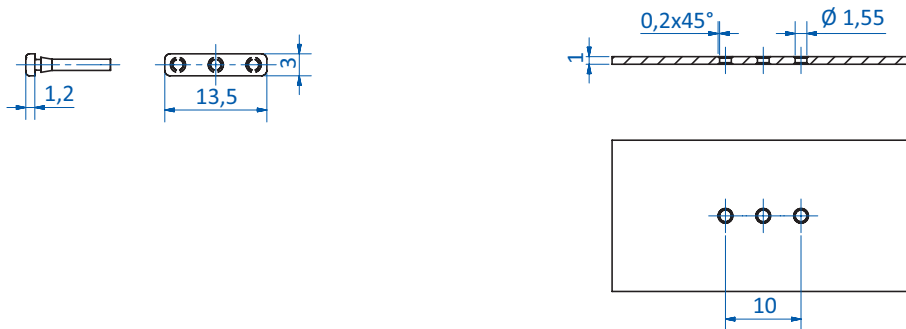

GR04.080-11H | GR04.080-11S

Continued on the next page



### Dimensions

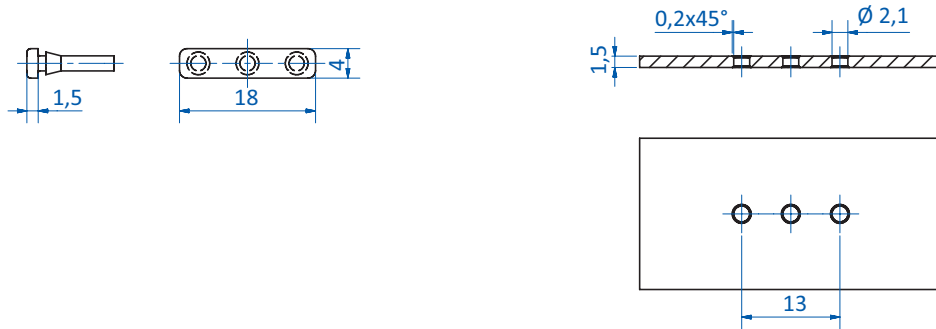

GR04.090-4 | GR04.090-4SI

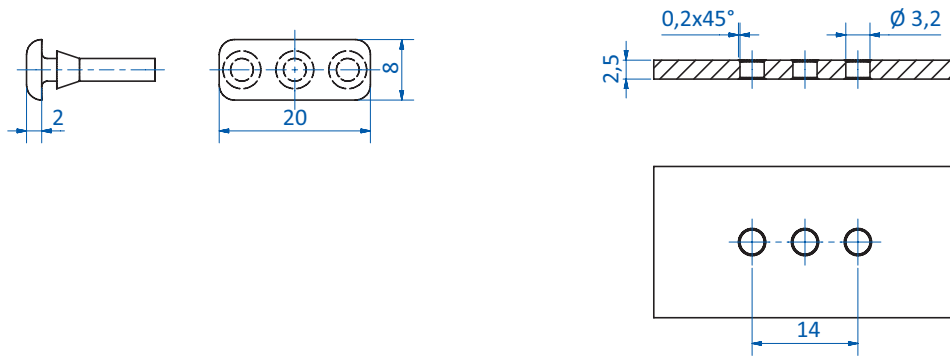

GR04.103-4 HNBR | GR04.103-HNBR-80SH | GR04.103-4 HNBR-F

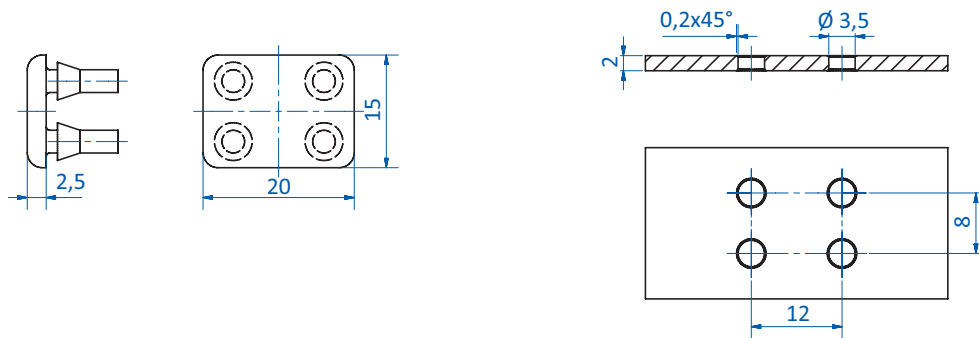

GR04.024-HNBR

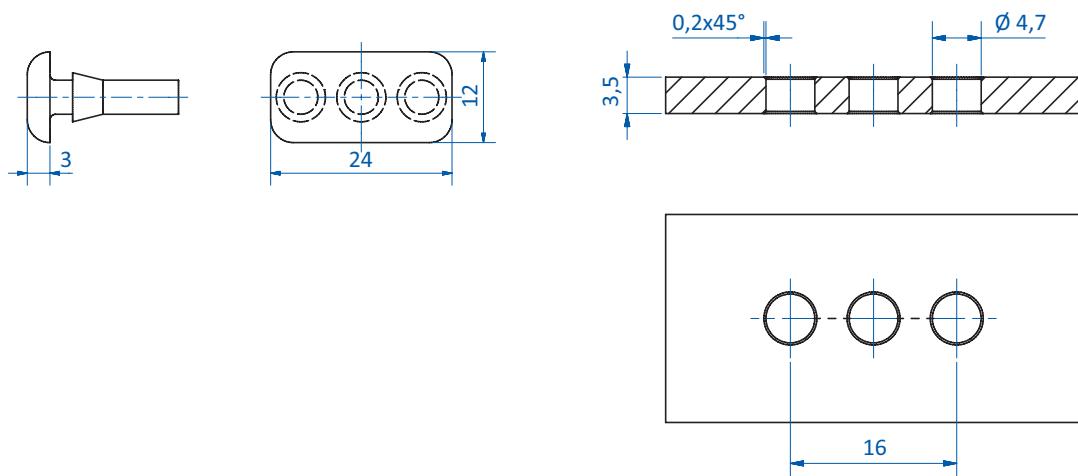

GR04.130C-4 HNBR | GR04.130C-4 HNBR-F



## Dimensions

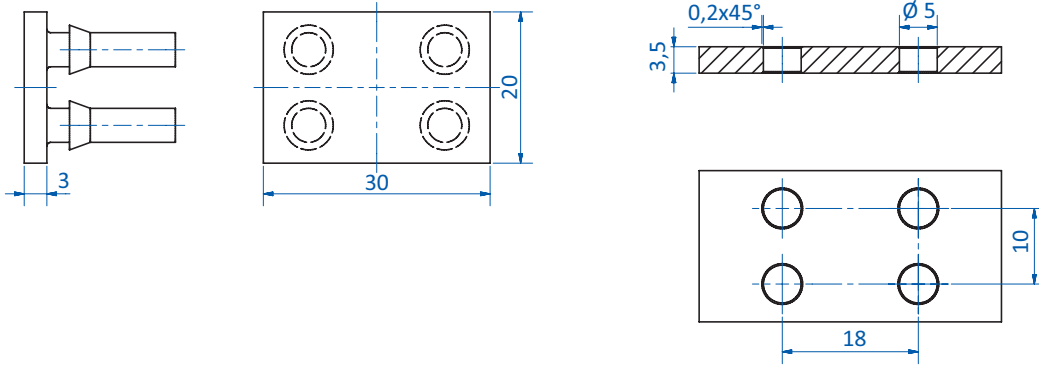

GR04.042-HNBR



# Grippers | Expansion grippers

ID grippers for diameters 8 - 81 mm

## ID grippers for diameters 8 - 81 mm



### Product notes

- > Single-acting grippers with high holding force
- > Gripper bellow expanded by pneumatically driven piston, clamps workpiece at its inner surface
- > Ventilation of gripper resets piston and bellow and releases workpiece
- > Piston movement adjustable to position of gripped object
- > Holding force controlled by feed pressure
- > Robust body, made of anodized, high-strength aluminum alloy
- > Elastomer bellows available in EPDM or silicone
- > Easy and non-destructive exchange of bellows
- > Piston movement adjustable to position of gripped object, bellow is not inflated, no risk of bursting

Downward piston movement (workpiece pushed):

- > Clamp the black part of gripper body or using optional extension tubes or threaded mounting brackets

Upward piston movement (workpiece drawn):

- > Clamp the red part of gripper body

**NOTES:** Not for sale for Italy, San Marino and USA

### Technical data

Item no.	Elastomer	For parts having an inner $\varnothing$ from/to [mm]	Optimal operating pressure [bar (psi)]	Weight [g]	Accessories
<b>GR04.F208</b>	EPDM	8 - 10	8 (116)	25	Extension tube: GR06.034, EPDM elastomer: GR04.208-1, Mounting bracket: GR02.280, Mounting bracket: GR02.227
<b>GR04.F208-SI</b>	Silicone	8 - 10	8 (116)	25	Extension tube: GR06.034, Silicone elastomer: GR04.208-2, Mounting bracket: GR02.280, Mounting bracket: GR02.227
<b>GR04.F210</b>	EPDM	10.5 - 13	8 (116)	26	Extension tube: GR06.034, EPDM elastomer: GR04.210-1, Mounting bracket: GR02.280, Mounting bracket: GR02.227
<b>GR04.F210-SI</b>	Silicone	10.5 - 13	8 (116)	26	Extension tube: GR06.034, Silicone elastomer: GR04.210-2, Mounting bracket: GR02.280, Mounting bracket: GR02.227
<b>GR04.F212</b>	EPDM	13 - 17	8 (116)	28	Extension tube: GR06.034, EPDM elastomer: GR04.212-1, Mounting bracket: GR02.280, Mounting bracket: GR02.227
<b>GR04.F212-SI</b>	Silicone	13 - 17	8 (116)	28	Extension tube: GR06.034, Silicone elastomer: GR04.212-2, Mounting bracket: GR02.280, Mounting bracket: GR02.227
<b>GR04.F214</b>	EPDM	15 - 19	8 (116)	31	Extension tube: GR06.034, EPDM elastomer: GR04.214-1, Mounting bracket: GR02.280, Mounting bracket: GR02.227
<b>GR04.F214-SI</b>	Silicone	15 - 19	8 (116)	31	Extension tube: GR06.034, Silicone elastomer: GR04.214-2, Mounting bracket: GR02.280, Mounting bracket: GR02.227
<b>GR04.F218</b>	EPDM	19 - 23.5	8 (116)	53	Extension tube: GR06.034, EPDM elastomer: GR04.218-1, Mounting bracket: GR02.281, Mounting bracket: GR02.227
<b>GR04.F218-SI</b>	Silicone	19 - 23.5	8 (116)	53	Extension tube: GR06.034, Silicone elastomer: GR04.218-2, Mounting bracket: GR02.281, Mounting bracket: GR02.227





### Technical data

Item no.	Elastomer	For parts having an inner $\varnothing$ from/to [mm]	Optimal operating pressure [bar (psi)]	Weight [g]	Accessories
<b>GR04.F222</b>	EPDM	23.5 - 31	8 (116)	83	Extension tube: GR06.035, EPDM elastomer: GR04.222-1, Mounting bracket: GR02.282, Mounting bracket: GR02.228
<b>GR04.F222-SI</b>	Silicone	23.5 - 31	8 (116)	83	Extension tube: GR06.035, Silicone elastomer: GR04.222-2, Mounting bracket: GR02.282, Mounting bracket: GR02.228
<b>GR04.F227</b>	EPDM	29 - 36.5	8 (116)	117	Extension tube: GR06.035, EPDM elastomer: GR04.227-1, Mounting bracket: GR02.283, Mounting bracket: GR02.228
<b>GR04.F227-SI</b>	Silicone	29 - 36.5	8 (116)	117	Extension tube: GR06.035, Silicone elastomer: GR04.227-2, Mounting bracket: GR02.283, Mounting bracket: GR02.228
<b>GR04.F233</b>	EPDM	34 - 44	8 (116)	182	Extension tube: GR06.036, EPDM elastomer: GR04.233-1, Mounting bracket: GR02.284, Mounting bracket: GR02.229
<b>GR04.F233-SI</b>	Silicone	34 - 44	8 (116)	182	Extension tube: GR06.036, Silicone elastomer: GR04.233-2, Mounting bracket: GR02.284, Mounting bracket: GR02.229
<b>GR04.F241</b>	EPDM	41 - 58	8 (116)	364	Extension tube: GR06.036, EPDM elastomer: GR04.241-1, Mounting bracket: GR02.285, Mounting bracket: GR02.229
<b>GR04.F241-SI</b>	Silicone	41 - 58	8 (116)	364	Extension tube: GR06.036, Silicone elastomer: GR04.241-2, Mounting bracket: GR02.285, Mounting bracket: GR02.229
<b>GR04.F251</b>	EPDM	52 - 64	8 (116)	611	Extension tube: GR06.037, EPDM elastomer: GR04.251-1, Mounting bracket: GR02.286, Mounting bracket: GR02.232
<b>GR04.F251-SI</b>	Silicone	52 - 64	8 (116)	611	Extension tube: GR06.037, Silicone elastomer: GR04.251-2, Mounting bracket: GR02.286, Mounting bracket: GR02.232
<b>GR04.F263</b>	EPDM	63 - 81	8 (116)	1,051	EPDM elastomer: GR04.263-1, Mounting bracket: GR02.287, Mounting bracket: GR02.233
<b>GR04.F263-SI</b>	Silicone	63 - 81	8 (116)	1,051	Silicone elastomer: GR04.263-2, Mounting bracket: GR02.287, Mounting bracket: GR02.233

### Elastomer replacement

EPDM Color black	Silicone Color red
<ul style="list-style-type: none"> <li>&gt; Non-marking</li> <li>&gt; Heat-resistant to 130 °C (266 °F)</li> </ul>	<ul style="list-style-type: none"> <li>&gt; Very long service life</li> <li>&gt; Heat-resistant to 200 °C (392 °F)</li> </ul>



# Grippers | Expansion grippers

ID grippers for diameters 8 - 81 mm

## Dimensions

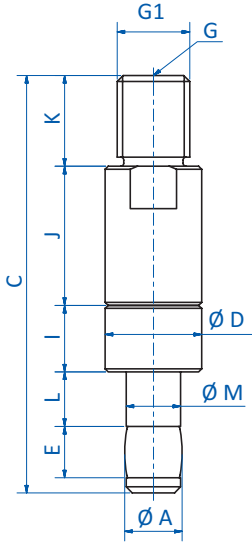

GR04.F208 | GR04.F208-SI | GR04.F210 | GR04.F210-SI |  
GR04.F212 | GR04.F212-SI | GR04.F214 | GR04.F214-SI

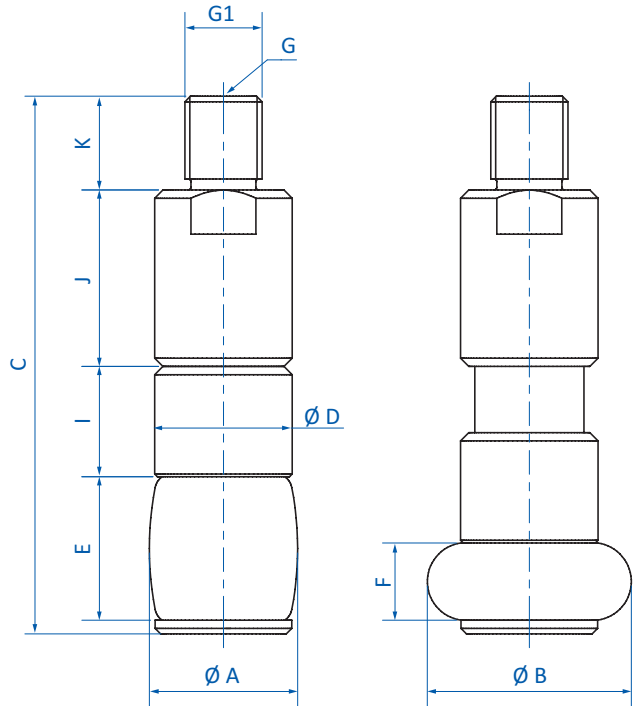

GR04.F218 | GR04.F218-SI | GR04.F222 | GR04.F222-SI |  
GR04.F227 | GR04.F227-SI | GR04.F233 | GR04.F233-SI |  
GR04.F241 | GR04.F241-SI | GR04.F251 | GR04.F251-SI |  
GR04.F263 | GR04.F263-SI

Item no.	G	G1	Ø A [mm]	Ø B [mm]	C [mm]	Ø D [mm]	E [mm]	F [mm]	I [mm]	J [mm]	K [mm]	L [mm]	Ø M [mm]
GR04.F208	M5	M12x1.5	8	10	67	16	7	3.5	11	23	15	9	7
GR04.F208-SI	M5	M12x1.5	8	10	67	16	7	3.5	11	23	15	9	7
GR04.F210	M5	M12x1.5	10.5	13	69	16	8.5	4.5	11	23	15	9	9
GR04.F210-SI	M5	M12x1.5	10.5	13	69	16	8.5	4.5	11	23	15	9	9
GR04.F212	M5	M12x1.5	13	17	71	16	10.5	5	11	23	15	9	11
GR04.F212-SI	M5	M12x1.5	13	17	71	16	10.5	5	11	23	15	9	11
GR04.F214	M5	M12x1.5	15	19	73	16	13	6	11	23	15	9	12
GR04.F214-SI	M5	M12x1.5	15	19	73	16	13	6	11	23	15	9	12
GR04.F218	M5	M12x1.5	19	23.5	78	20	16.5	9	20	23.5	15	--	--
GR04.F218-SI	M5	M12x1.5	19	23.5	78	20	16.5	9	20	23.5	15	--	--
GR04.F222	M5	M14x1,5	23.5	31	93	23	21	9	20	32	17	--	--
GR04.F222-SI	M5	M14x1,5	23.5	31	93	23	21	9	20	32	17	--	--
GR04.F227	M5	M14x1,5	29	36.5	98	25	26	14	20	32	17	--	--
GR04.F227-SI	M5	M14x1,5	29	36.5	98	25	26	14	20	32	17	--	--
GR04.F233	G1/8	M16x1.5	34	44	113	30	33.5	24	20	37.5	19	--	--
GR04.F233-SI	G1/8	M16x1.5	34	44	113	30	33.5	24	20	37.5	19	--	--
GR04.F241	G1/8	M16x1.5	41	58	138	40	41.5	14	20	54.5	19	--	--
GR04.F241-SI	G1/8	M16x1.5	41	58	138	40	41.5	14	20	54.5	19	--	--
GR04.F251	G1/8	M20x1.5	52	64	148	50	53	35	30	42	19	--	--
GR04.F251-SI	G1/8	M20x1.5	52	64	148	50	53	35	30	42	19	--	--
GR04.F263	G1/8	M24x1.5	63	81	176	60	61	36	36	56	19	--	--
GR04.F263-SI	G1/8	M24x1.5	63	81	176	60	61	36	36	56	19	--	--



## Installation examples

> Clamping the upper part of gripper body enables downward piston movement (workpiece pushed) GR02.280 - GR02.287

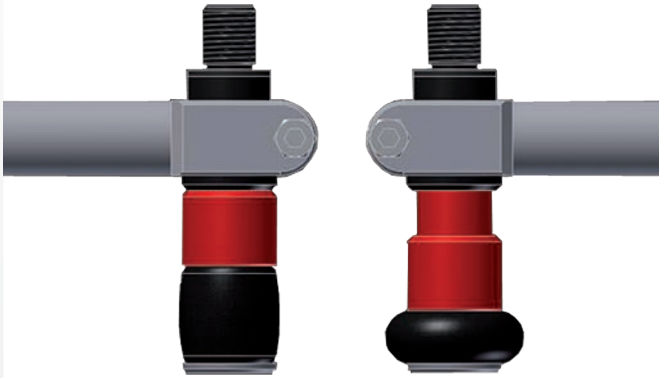

> Clamping the lower gripper body enables upward piston movement (workpiece drawn) GR02.280 - GR02.287

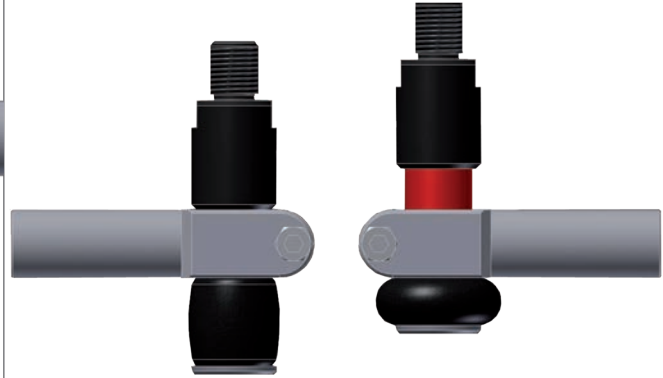

> Clamping to extension tubes enables downward piston movement (workpiece pushed) GR06.034 - GR06.037

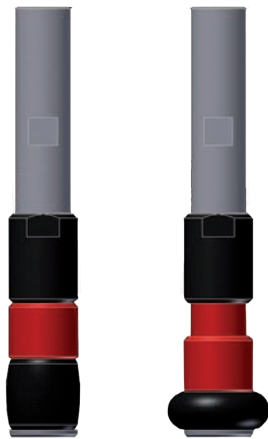

> Fitting to threaded mounting brackets enables downward piston movement (workpiece pushed) GR02.227 - 229 and GR02.232 - GR02.233

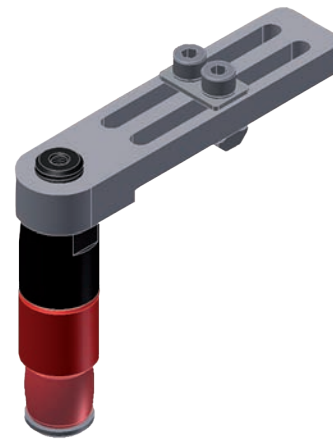

> Application example

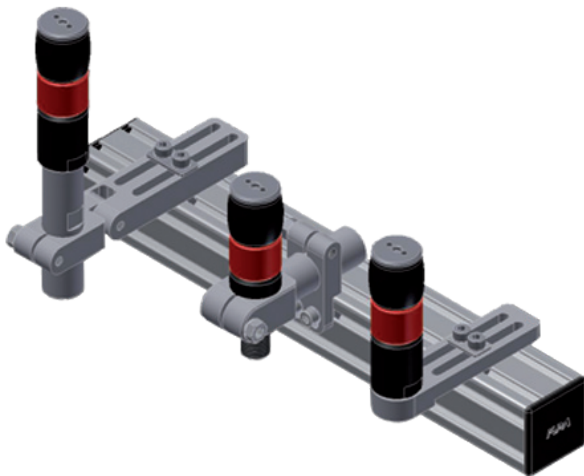



### Extension tubes for ID grippers



#### Product notes

- > Extension tubes with rear-side compressed air connection and through hole
- > For mounting ID grippers to angle clamps
- > Suitable for ID grippers GR04 with index F

#### Technical data

Item no.	Suitable for	Weight [g]
<b>GR06.034</b>	GR04.F208 - GR04.F218	56
<b>GR06.035</b>	GR04.F222 - GR04.F227	54
<b>GR06.036</b>	GR04.F233 - GR04.F241	45
<b>GR06.037</b>	GR04.F251	118

#### Dimensions

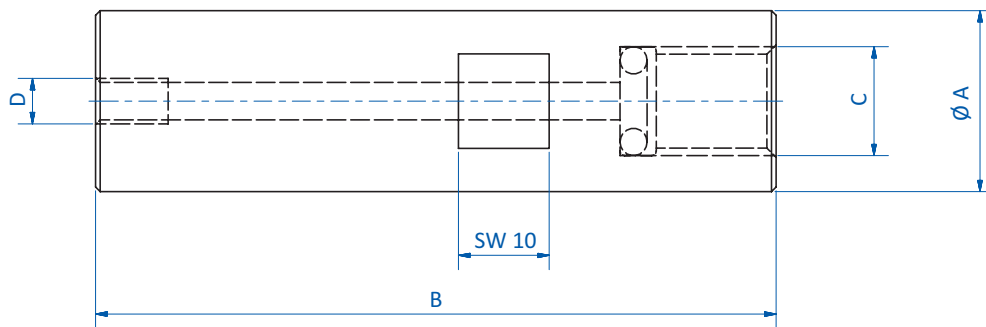

Item no.	Ø A [mm]	B [mm]	C	D
<b>GR06.034</b>	20	75	M12x1.5	M5
<b>GR06.035</b>	20	75	M14x1.5	M5
<b>GR06.036</b>	20	75	M16x1.5	G1/8
<b>GR06.037</b>	30	75	M20x1.5	G1/8



### Mounting brackets for ID grippers

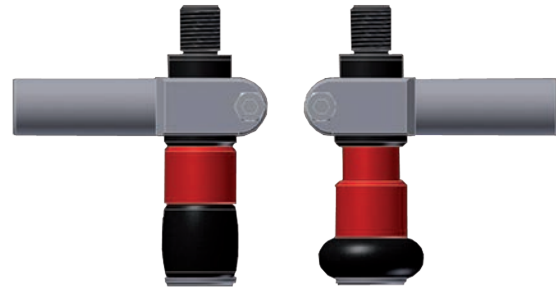

#### Product notes

- > Mounting brackets for variable angle installation of ID grippers
- > Clamping grippers to upper part (red) enables upward movement, workpiece is drawn
- > Clamping grippers to bottom part (black) or clamping to extension tube enables downward movement, workpiece is pushed
- > Suitable for ID grippers GR04 with index F

#### Technical data

Item no.	Suitable for expansion grippers	Weight [g]
GR02.280	GR04.F208, GR04.F212, GR04.F214	18
GR02.281	GR04.F218	36
GR02.282	GR04.F222	40
GR02.283	GR04.F227	50
GR02.284	GR04.F233	57
GR02.285	GR04.F241	68
GR02.286	GR04.F251	145
GR02.287	GR04.F263	172

#### Dimensions

$\varnothing A$ [mm]	B [mm]	C [mm]	D [mm]	E [mm]	F [mm]	G [mm]	$\varnothing H$ [mm]
10	60	30	11	20	26	10	16
14	74	40	13	24	30	20	20
14	77	40	14.5	27	33	20	23
20	89	50	15.5	29	35	20	25
20	94	50	18	34	40	20	30
20	104	50	23	44	45	20	40
30	124	60	27	54	50	30	50
30	134	60	32	64	57	30	60

#### Dimensions

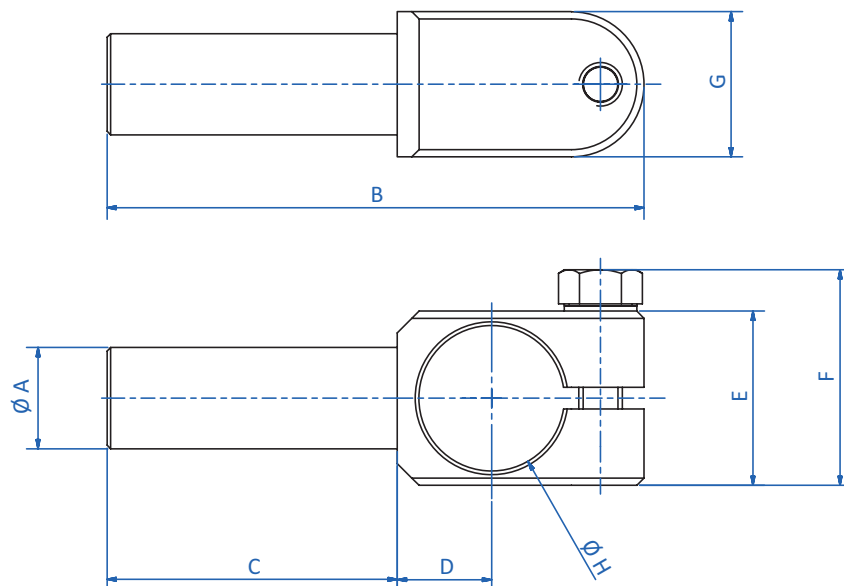



# Grippers | Expansion grippers

Threaded mounting brackets for ID grippers

## Threaded mounting brackets for ID grippers



### Product notes

- > Threaded mounting brackets for installation the grippers on profiles
- > Threaded mounting bracket enables downward movement of piston of ID gripper, workpiece is pushed
- > Suitable for ID grippers GR04 with index F
- > Slot nuts and mounting screws included in scope of delivery

### Technical data

Item no.	Suitable for expansion grippers	Weight [g]
GR02.227	GR04.F208 - GR04.F218	50
GR02.228	GR04.F222 - GR04.F227	53
GR02.229	GR04.F233 - GR04.F241	57
GR02.232	GR04.F251	63
GR02.233	GR04.F263	70

### Dimensions

A [mm]	B [mm]	C [mm]	D [mm]	E [mm]	F [mm]	G
22	99	23	55	12	8.5	M12x1.5
24	99	22	55	12	8.5	M14x1.5
26	99	21	55	12	8.5	M16x1.5
28	110	21	65	12	8.5	M20x1.5
32	110	21	65	12	8.5	M24x1.5

### Dimensions

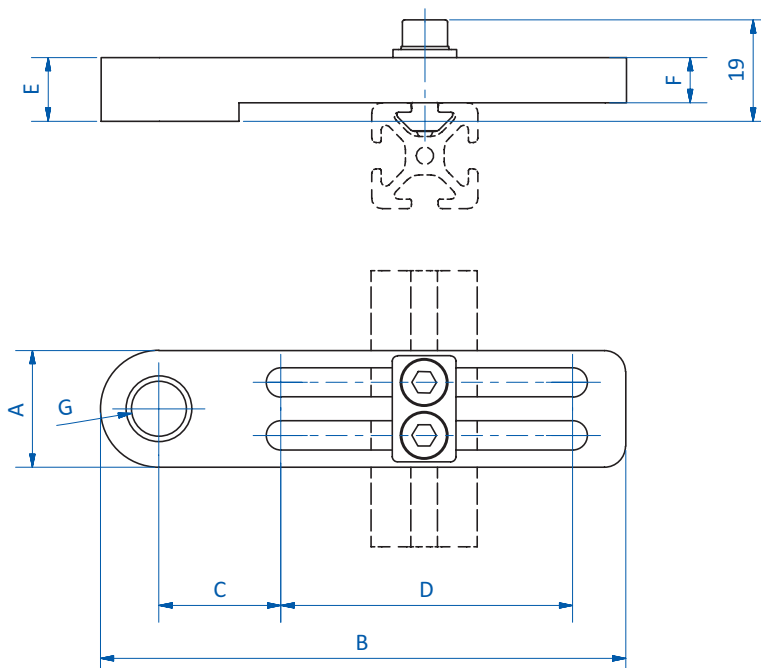



Needle grippers GR04.711



Product notes

- > Gripper for materials that are non-dimensionally stable or difficult to handle with vacuum
- > Stroke limitation by spacer plates
- > Needles centrally crossed for firm grip
- > Double-acting enables short duty cycles: separate compressed air connections for extraction/retraction of needles
- > Needles can be individually replaced

Technical data

Item no.	GR04.711-25	GR04.711-40	GR04.711-60
Principle of operation	double-acting	double-acting	double-acting
Stroke [mm]	2.5	4	6
Number of needles [Pcs.]	12	12	12
Needle diameter [mm]	2	2	2
Infeed angle [°]	30	30	30
Operating pressure [bar (psi)]	2.5 - 8 (36.3 - 116)	2.5 - 8 (36.3 - 116)	2.5 - 8 (36.3 - 116)
Operating temperature [°C (°F)]	-10 - 60 (14 - 140)	-10 - 60 (14 - 140)	-10 - 60 (14 - 140)
Weight [g]	313	311	310
Accessories	Needle block GR04.711-P4 Sensor: GR04.202N Sensor: GR04.202P	Needle block GR04.711-P4 Sensor: GR04.202N Sensor: GR04.202P	Needle block GR04.711-P4 Sensor: GR04.202N Sensor: GR04.202P

Dimensions

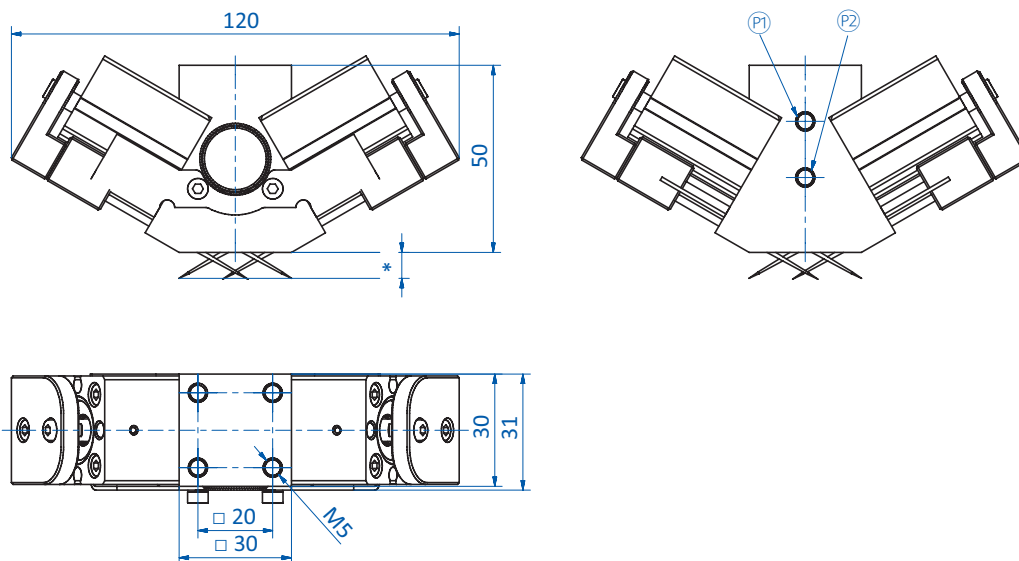

Ⓟ = Compressed air connection M5 needles extended Ⓠ = Compressed air connection M5 needles retracted \* = Stroke



# Grippers | Needle grippers

Needle grippers GR04.740B

## Needle grippers GR04.740B



### Product notes

- > Gripper for materials that are non-dimensionally stable or difficult to handle with vacuum
- > Alignment to material thickness via adjustable stroke
- > Double-acting, enables short duty cycles: separate compressed air connections for extraction/retraction of needles
- > Internal stroke guiding for extra slim design
- > Sensor for monitoring gripper action via piston position (needles extracted/retracted)
- > Stroke corresponds to maximum entry depth of needles
- > Sensors and spare needle sets with four needles each, available as accessories
- > PNP and NPN sensors:
  - C-nut (cable: 90°): GR04.202P, GR04.202N
  - C-nut (cable: straight, short design): GR04.280P, GR04.280N

### Technical data

Item no.	GR04.740B
Principle of operation	double-acting
Stroke [mm]	0 - 3
Number of needles [Pcs.]	4
Needle diameter [mm]	2
Infeed angle [°]	45
Operating pressure [bar (psi)]	2 - 8 (29 - 116)
Operating temperature [°C (°F)]	-10 - 80 (14 - 176)
Weight [g]	226
Accessories	Spare needle kit: GR04.740B-30N Sensor: GR04.280N Sensor: GR04.280P Sensor: GR04.202N Sensor: GR04.202P





Dimensions

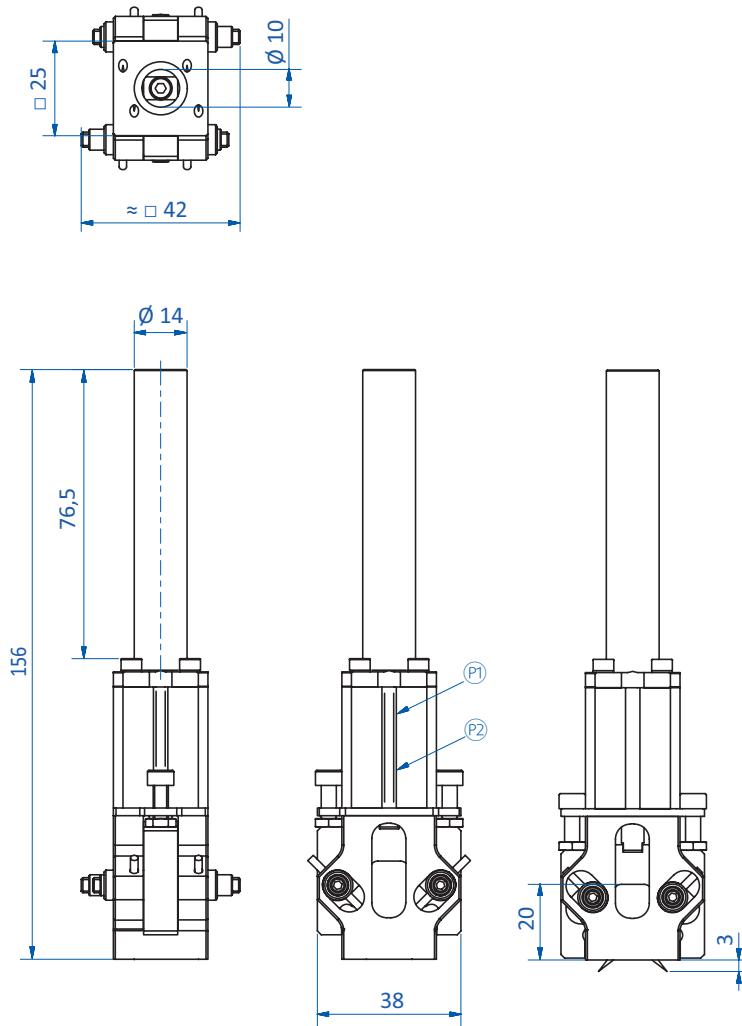

Ⓟ = Compressed air connection M5 needles extended Ⓠ = Compressed air connection M5 needles retracted



# Grippers | Needle grippers

Needle grippers GR04.700 and GR04.730

## Needle grippers GR04.700 and GR04.730

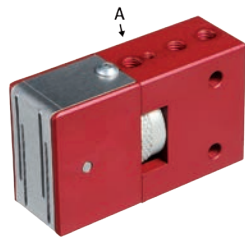

GR04.700



GR04.730

### Product notes

- > Small needle diameter for low entry depth, blow-off function for fast product release
- > Grippers with flat entry angle enables handling of thin or flat parts
- > Knurled screw for stroke adjustment to textile thickness
- > GR04.700: double-acting enables short duty cycles: separate compressed air connections for extraction/retraction of needles
  - Additional compressed air inlet (A) for fast product release
- > GR04.730: single-acting, compressed air connection for needle extraction, reset via return spring
- > Stroke corresponds to maximum entry depth of needles
- > Spare needle plates available as accessories

### Technical data

Item no.	GR04.700-20	GR04.700-25	GR04.730-20
Principle of operation	double-acting	double-acting	single-acting
Stroke [mm]	0 - 2	0 - 2.5	0 - 2
Number of needles [Pcs.]	32	32	32
Needle diameter [mm]	0.7	0.7	0.7
Infeed angle [°]	30	30	30
Operating pressure [bar (psi)]	4 - 7 (58 - 101.5)	4 - 7 (58 - 101.5)	4 - 7 (58 - 101.5)
Operating temperature [°C (°F)]	-0 - 70 (32 - 158)	-0 - 70 (32 - 158)	-0 - 70 (32 - 158)
Weight [g]	114	114	250
Accessories	Spare needle kit: GR04.700-20N	Spare needle kit: GR04.700-25N	Spare needle kit: GR04.730-20N Mounting bracket: GR07.041



Dimensions

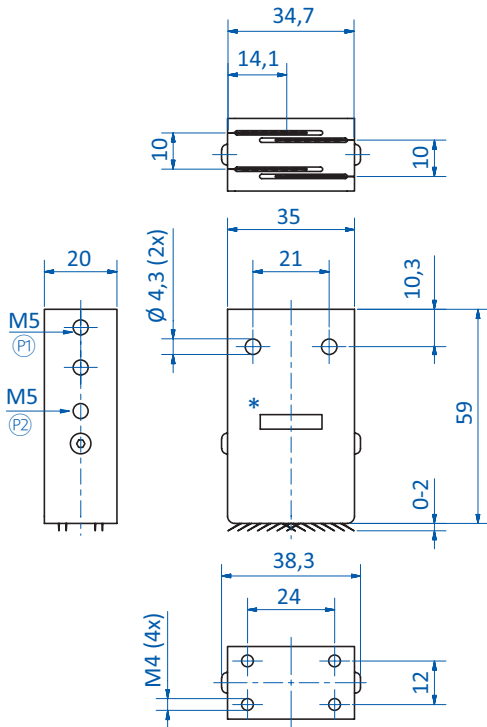

GR04.700-20

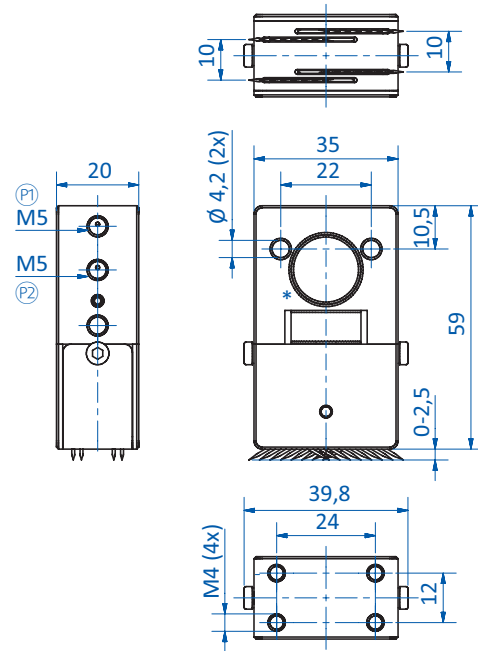

GR04.700-25

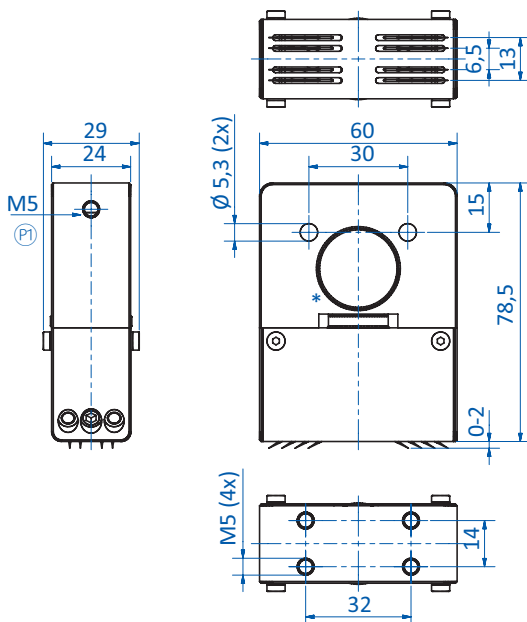

GR04.730-20

\* = Stroke adjustment with knurled screw (P1) = Compressed air connection M5 needles extended  
 (P2) = Compressed air connection M5 needles retracted



# Grippers | Needle grippers

Needle grippers GR04.710 and GR04.720

## Needle grippers GR04.710 and GR04.720

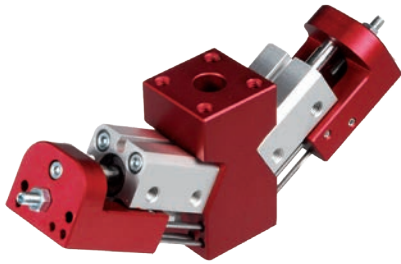

GR04.710

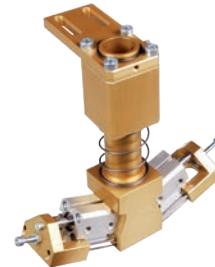

GR04.720 with spring load

### Product notes

- > Strokes adjustable to material thickness
- > Grippers for materials that are non-dimensionally stable or difficult to handle with vacuum
- > Central bore hole (Ø 10 mm) to allow insertion of gripper into stack rails for pick & place
- > Stroke limitation adjustable to material thickness
- > Needles centrally crossed for firm grip
- > Double-acting enables short duty cycles: separate compressed air connections for extraction/retraction of needles
- > Needles can be individually replaced
- > Spare needle sets, each containing ten pieces available

### Technical data

Item no.	GR04.710-25	GR04.710-50	GR04.710-75	GR04.710-100	GR04.720-25	GR04.720-50
Principle of operation	double-acting	double-acting	double-acting	double-acting	double-acting	double-acting
Stroke [mm]	0 - 2.5	0 - 5	0 - 7.5	0 - 10	0 - 2.5	0 - 5
Stroke suspensions [mm]	--	--	--	--	35	35
Number of needles [Pcs.]	10	10	10	10	10	10
Needle diameter [mm]	2	2	2	2	2	2
Infeed angle [°]	30	30	30	30	30	30
Operating pressure [bar (psi)]	2 - 8 (29 - 116)	2 - 8 (29 - 116)	2 - 8 (29 - 116)	2 - 8 (29 - 116)	2 - 8 (29 - 116)	2 - 8 (29 - 116)
Operating temperature [°C (°F)]	-10 - 80 (14 - 176)	-10 - 80 (14 - 176)	-10 - 80 (14 - 176)	-10 - 80 (14 - 176)	-10 - 80 (14 - 176)	-10 - 80 (14 - 176)
Weight [g]	240	298	310	340	492	512
Accessories	Spare needle kit: GR04.710-50N Sensor: GR04.198 Sensor: GR04.198/NPN Sensor: GR04.202N Sensor: GR04.202P	Spare needle kit: GR04.710-50N Sensor: GR04.198 Sensor: GR04.198/NPN Sensor: GR04.202N Sensor: GR04.202P	Spare needle kit: GR04.710-75AN Spare needle kit: GR04.710-75N Sensor: GR04.198 Sensor: GR04.198/NPN Sensor: GR04.202N Sensor: GR04.202P	Spare needle kit: GR04.710-75AN Spare needle kit: GR04.710-75N Sensor: GR04.198 Sensor: GR04.198/NPN Sensor: GR04.202N Sensor: GR04.202P	Spare needle kit: GR04.720-25N	Spare needle kit: GR04.720-25N



Dimensions

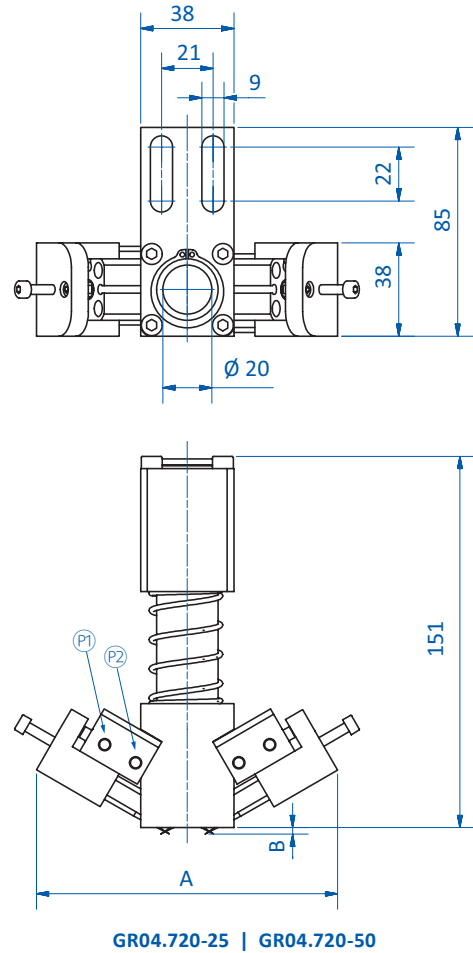
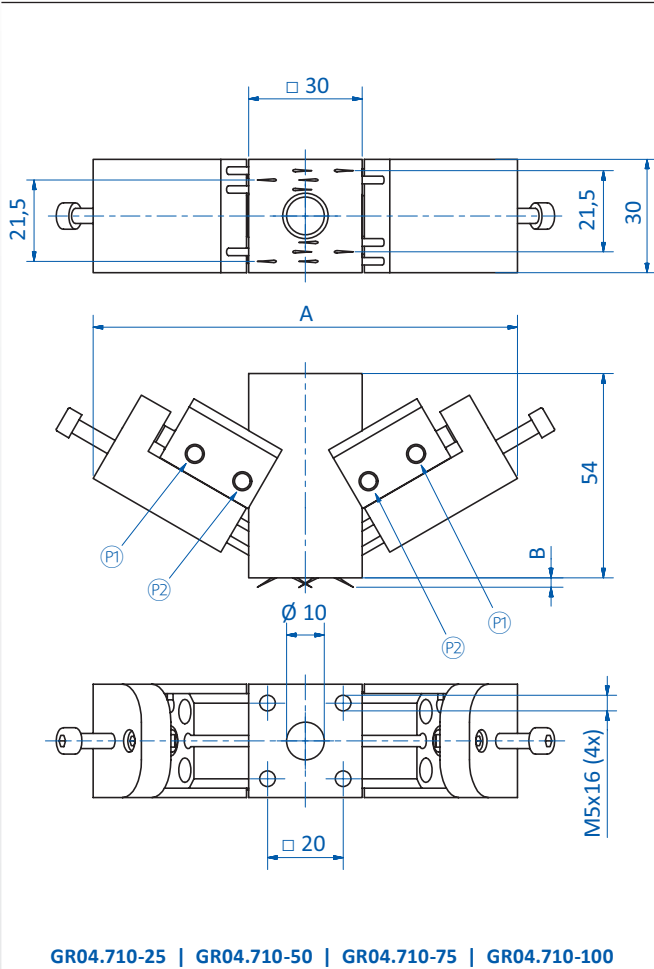

Ⓟ = Compressed air connection M5 needles extended Ⓠ = Compressed air connection M5 needles retracted

Item no.	GR04.710-25	GR04.710-50	GR04.710-75	GR04.710-100	GR04.720-25	GR04.720-50
A [mm]	111.5 - 123	120 - 138	128 - 154	138.5 - 173	123 - 131.5	131.5 - 149
B [mm]	0 - 2.7	0 - 5	0 - 7.5	0 - 10	0 - 2.5	0 - 5



### Needle grippers GR04.750



#### Product notes

- > Grippers for materials that are non-dimensionally stable or difficult to handle with vacuum
- > Central bore hole ( $\varnothing$  11.5 mm) to allow insertion of gripper into stack rails for pick & place
- > Needles centrally crossed for firm grip
- > Double-acting enables short duty cycles: compressed air connections for extraction/retraction of needles
- > Needles can be individually replaced
- > Easy adjustment of needle depth, markings at 1, 2, 3 and 4 mm

#### Technical data

<b>Item no.</b>	<b>GR04.750</b>
<b>Principle of operation</b>	double-acting
<b>Stroke [mm]</b>	4.5
<b>Number of needles [Pcs.]</b>	4
<b>Needle diameter [mm]</b>	2.35
<b>Infeed angle [°]</b>	30
<b>Operating pressure [bar (psi)]</b>	2.5 - 8 (36.3 - 116)
<b>Operating temperature [°C (°F)]</b>	-10 - 80 (14 - 176)
<b>Weight [g]</b>	280
<b>Accessories</b>	Spare needle kit: GR04.750-07N Sensor: GR04.280N Sensor: GR04.280P Sensor: GR04.202N Sensor: GR04.202P Connecting cable: 20.503 Connecting cable: 20.507



Dimensions

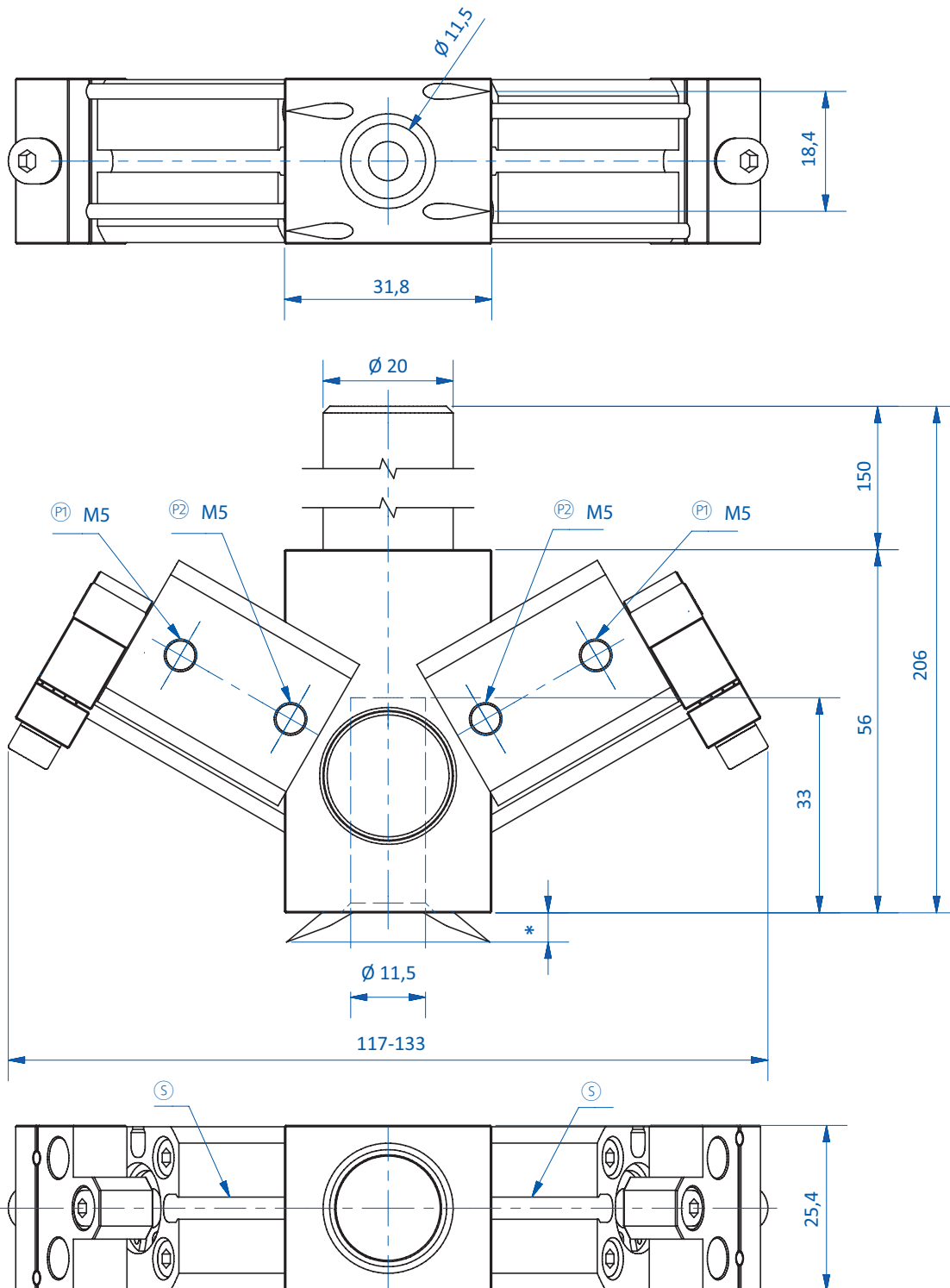

Ⓟ = Compressed air connection M5 needles extended Ⓠ = Compressed air connection M5 needles retracted Ⓢ = Sensor slot \* = Stroke



### Needle grippers GR04.715



#### Product notes

- > Grippers for workpieces or materials that are non-dimensionally stable or difficult to handle with vacuum
- > Narrow design
- > Stroke can be adjusted to material thickness
- > Double-acting enables short duty cycles: separate compressed air connections for extraction/retraction of needles on the face-side
- > Needles can be individually replaced
- > Spare needle sets, each containing ten pieces available

#### Technical data

<b>Item no.</b>	<b>GR04.715-70</b>
<b>Principle of operation</b>	double-acting
<b>Stroke [mm]</b>	0 - 7
<b>Number of needles [Pcs.]</b>	6
<b>Needle diameter [mm]</b>	2
<b>Infeed angle [°]</b>	30
<b>Operating pressure [bar (psi)]</b>	2 - 8 (29 - 116)
<b>Operating temperature [°C (°F)]</b>	-10 - 80 (14 - 176)
<b>Weight [g]</b>	195
<b>Accessories</b>	Spare needle kit: GR04.715-70N Mounting bracket: GR07.042 Sensor: GR04.198 Sensor: GR04.198/NPN Sensor: GR04.202P Sensor: GR04.202N Sensor: GR04.280P Sensor: GR04.280N Sensor: GS04.005 Sensor: GS04.006





Dimensions

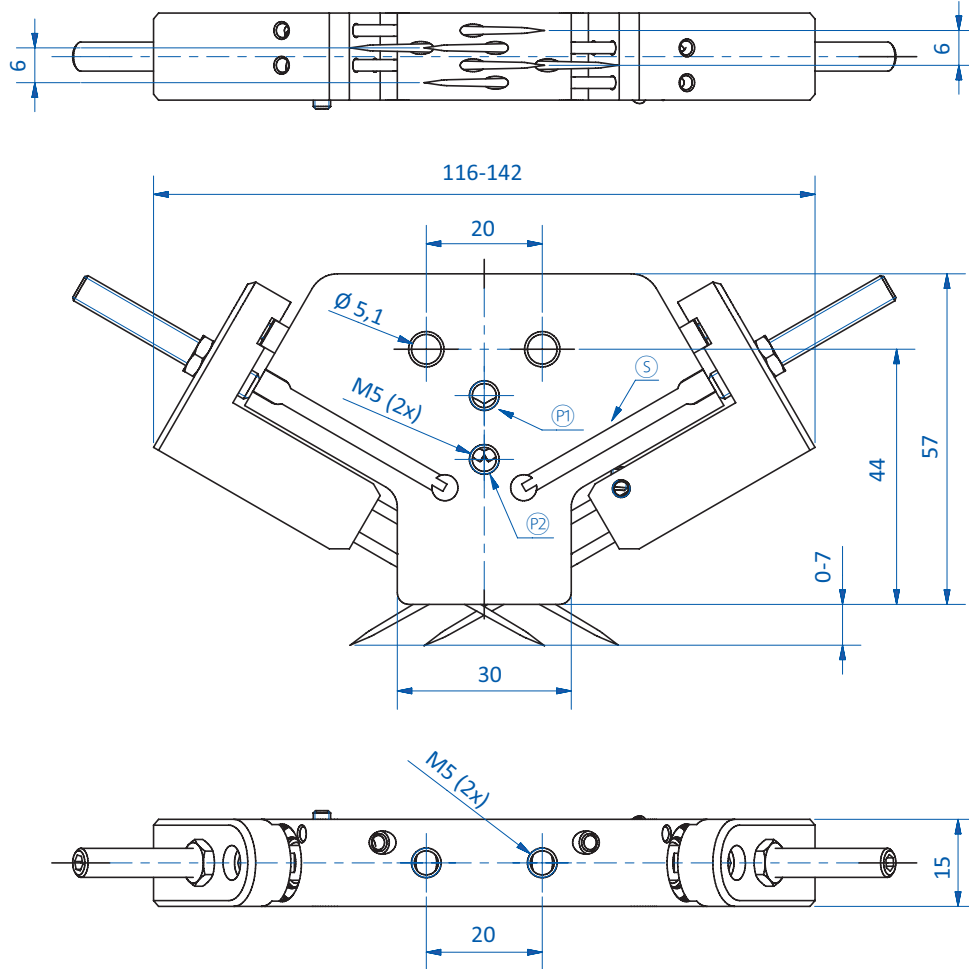

Ⓟ = Bore holes M5 for central extraction of needles Ⓠ = Bore hole M5 for central retraction of needles Ⓡ = Sensor slot



### Needle grippers GR04.725

ESPECIALLY SUITED FOR HANDLING HEAVIER WORKPIECES



#### Product notes

- > Grippers for materials that are non-dimensionally stable or difficult to handle with vacuum
- > Double-acting enables short duty cycles: separate compressed air connections for extraction/retraction of needles
- > Spare needle plates, available

#### Technical data

Item no.	GR04.725-60	GR04.725-60V	GR04.725-90	GR04.725-90V	GR04.725-200
Principle of operation	double-acting	double-acting	double-acting	double-acting	double-acting
Stroke [mm]	6	6	9	9	20
Needle stroke adjustable	no	yes	no	yes	no
Number of needles [Pcs.]	32	32	32	32	32
Needle diameter [mm]	2	2	2	2	2
Infeed angle [°]	45	45	45	45	45
Max. gripping force [N]	360	360	360	360	360
Operating pressure [bar (psi)]	2 - 8 (29 - 116)	2 - 8 (29 - 116)	2 - 8 (29 - 116)	2 - 8 (29 - 116)	2 - 8 (29 - 116)
Operating temperature [°C (°F)]	0 - 70 (32 - 158)	0 - 70 (32 - 158)	0 - 70 (32 - 158)	0 - 70 (32 - 158)	0 - 70 (32 - 158)
Weight [g]	450	450	480	480	1,750
Accessories	Spare needle kit: GR04.725-60N Mounting bracket: GR07.041	Spare needle kit: GR04.725-60N Mounting bracket: GR07.041	Spare needle kit: GR04.725-90N Mounting bracket: GR07.041	Spare needle kit: GR04.725-90N Mounting bracket: GR07.041	Spare needle kit: GR04.725-200N Mounting bracket: GR07.041



Dimensions

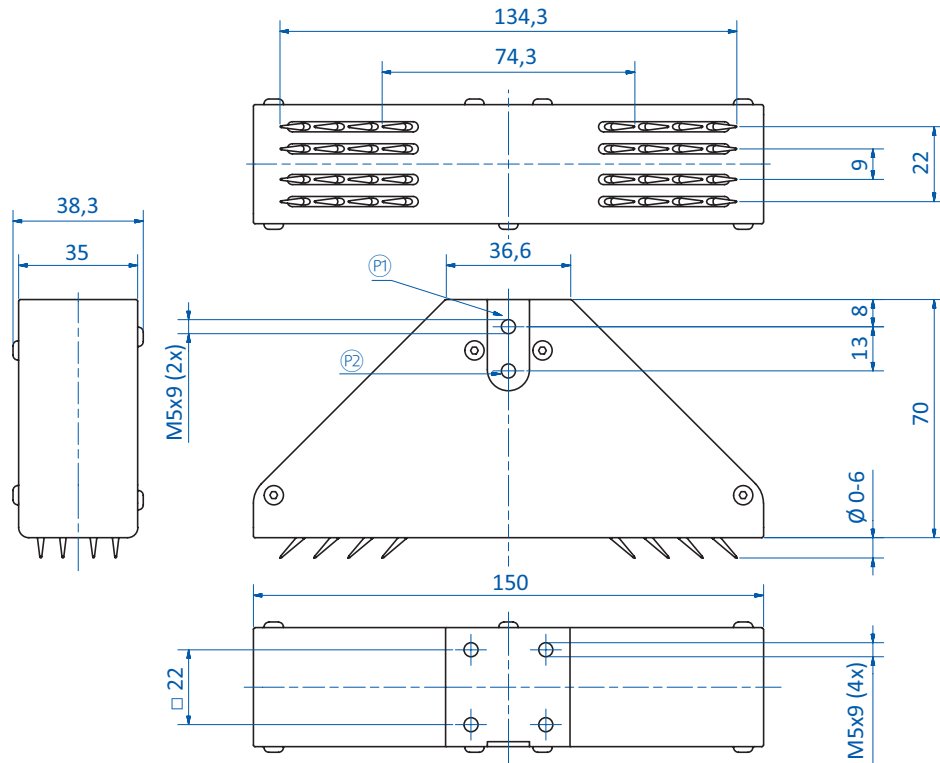

GR04.725-60 | GR04.725-60V

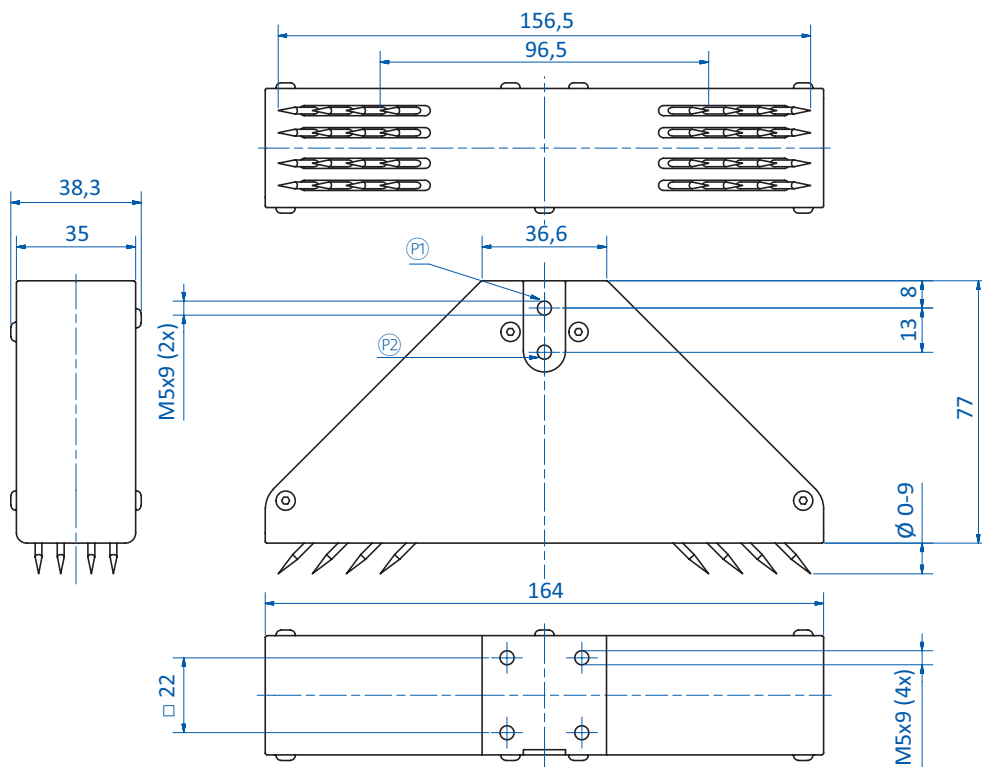

GR04.725-90 | GR04.725-90V

Ⓟ = Compressed air connection M5 needles extended Ⓠ = Compressed air connection M5 needles retracted

Continued on the next page



### Dimensions

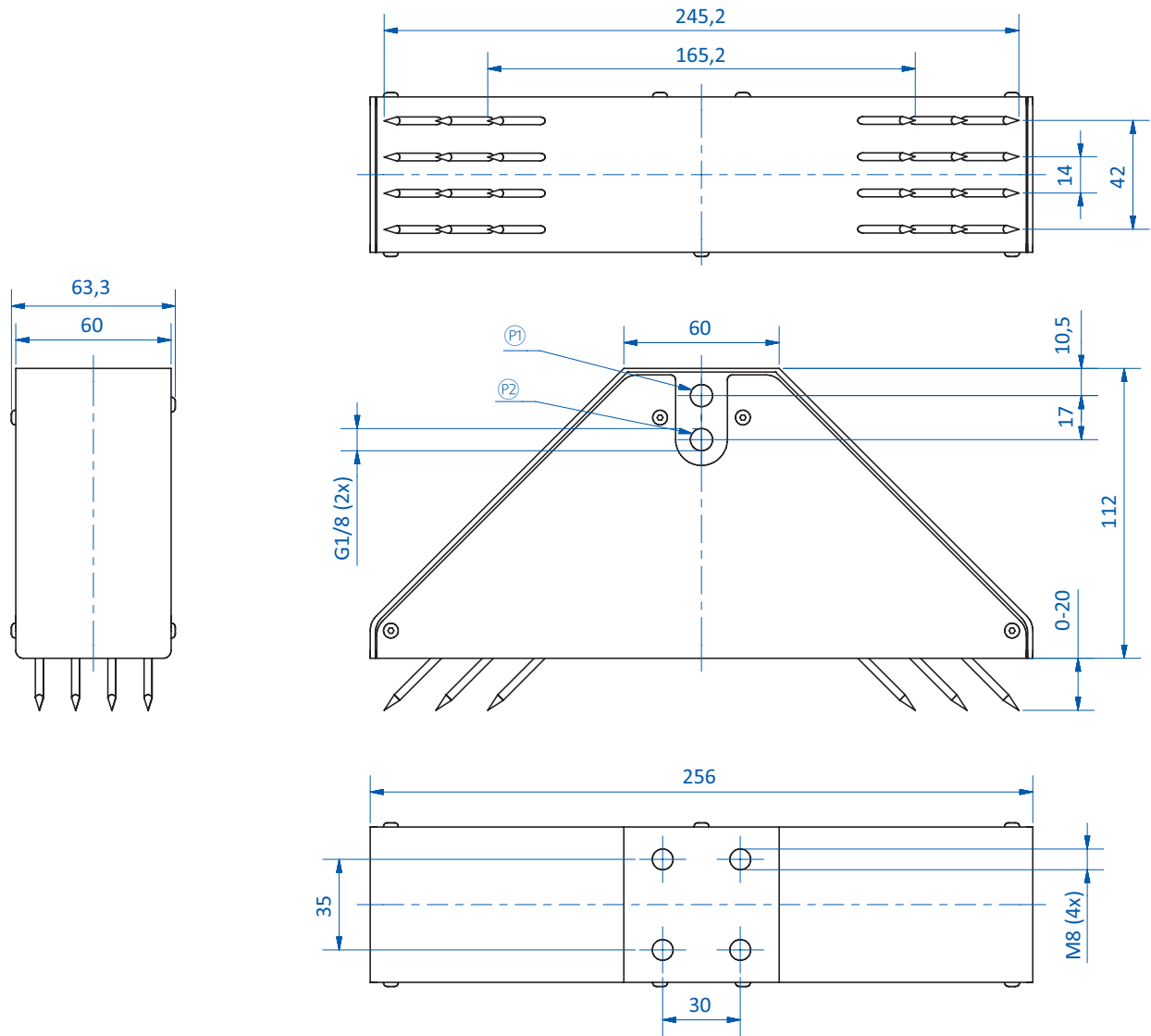

GR04.725-200

Ⓟ = Compressed air connection M5 needles extended    Ⓠ = Compressed air connection M5 needles retracted



Mounting plates for needle gripper



Product notes

- > Mounts needle grippers on the SLine and MLine extrusion systems or spring loaded suction fingers
- > Two bore holes for DIN 912-M5, for mounting on extrusion
- > Slot nuts and screws included in scope of delivery

Technical data

Item no.	Suitable for	Weight [g]	Suitable suction fingers
GR07.041	GR04.725, GR04.730	27	GR03.090A GR03.091A

Application examples



Installation example for needle gripper GR04.700 on spring loaded suction finger or FIPA SLine extrusion system

Dimensions

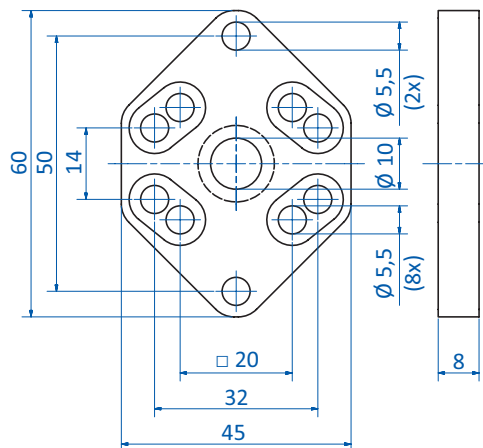



# Grippers | Needle grippers

Mounting bracket for needle gripper GR04.715

## Mounting bracket for needle gripper GR04.715



### Product notes

- > Mounted needle gripper on the SLine and MLine extrusion systems or on spring loaded suction finger
- > Two bore holes for DIN 912-M5, for mounting on extrusion with slot nuts
- > Slot nuts and screws included in scope of delivery

### Technical data

Item no.	Suitable for	Weight [g]	Suitable suction fingers
<b>GR07.042</b>	GR07.115	11	GR03.090A GR03.091A

### Dimensions

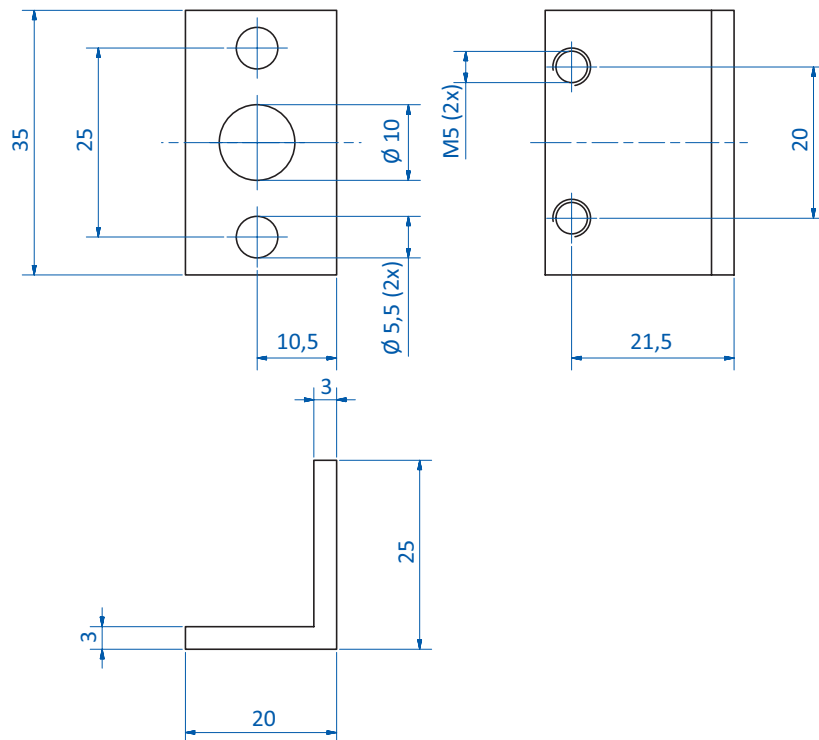



### Magnetic grippers – electrical controlled



#### Product notes

- > Safe handling of sheet metal or ferromagnetic workpieces with or without recesses
- > Very high holding force thanks to high-performance permanent magnet
- > Safe holding of the workpiece during power failures
- > NC normally closed
- > Short cycle times for thin and/or alloyed metal sheets thanks to negligible residual magnetism after switching off the magnetic force
- > No compressed air required
- > Very energy-efficient as a short electrical pulse is only required for product release
- > Robust design
- > Indicated holding forces are valid for direct placement, without air gap, on the flat holding surface

#### Technical data

Item no.	MG35	MG55	MG70
Principle of operation	electrical	electrical	electrical
Rated power [W]	4.6	9	13.3
Gripping force [N]	160	420	720
Residual gripping force [N]	< 1	< 1	< 1
Operating voltage of the switch-off coil [V]	24	24	24
Power-on time [ED]	25 % ED at < 2 min.	25 % ED at < 2 min.	25 % ED at < 2 min.
Min. recommended sheet thickness [mm]	3	4.5	6
Protection class	IP65	IP65	IP65
Max. operating temperature [°C (°F)]	0 - 70 (32 - 158)	0 - 70 (32 - 158)	0 - 70 (32 - 158)
Weight [g]	200	500	900
Suitable fittings	270.448	270.449	270.450

#### Dimensions

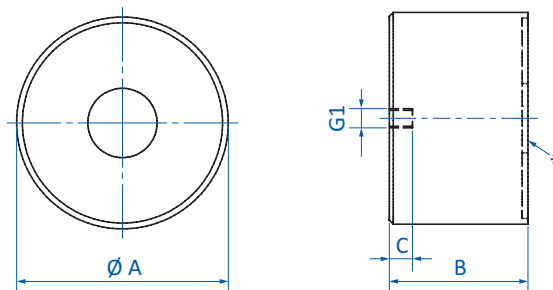

\* = Holding surface

Item no.	MG35	MG55	MG70
G1	M4	M5	M8
Ø A [mm]	35	55	70
B [mm]	30	36	45
C [mm]	5	6	8



### Bernoulli vacuum cups SX-B



Housing made of anodized aluminum

#### Product notes

- > Integrated vacuum generation on the Bernoulli principle
- > Non-contact, deformation-resistant transport of thin and sensitive products
- > Suitable for porous products thanks to high volume flow at low vacuum level
- > Easy to install, system flexibly expandable through lateral compressed air inlets
- > Long life cycle due to maintenance-free operation
- > Only operate with unoled, dry compressed air
- > With 65.530 and 65.540, the pads (Thermalon) can be removed for contact-free applications
- > Pads are included in scope of delivery

#### Technical data

Item no.	Model	Operating pressure [bar (psi)]	Holding force at 5 bar (72,5 psi) [N]	Air consumption at 5 bar (72,5 psi) [l/min]	Max. particle size [ $\mu$ m]	Diameter [mm]	Ambient air temperature [ $^{\circ}$ C ( $^{\circ}$ F)]	Weight [g]	Suitable spare pads
65.510	SX-B-20	1 - 6 (14.5 - 87)	2.5	96	40	20	5 - 60 (41 - 140)	13	78.509
65.520	SX-B-30	1 - 6 (14.5 - 87)	4	100	40	30	5 - 60 (41 - 140)	31	78.509
65.530	SX-B-40	1 - 6 (14.5 - 87)	6.5	100	40	40	5 - 60 (41 - 140)	52	78.511
65.540	SX-B-60	1 - 6 (14.5 - 87)	13	150	40	60	5 - 60 (41 - 140)	120	78.511







### Dimensions

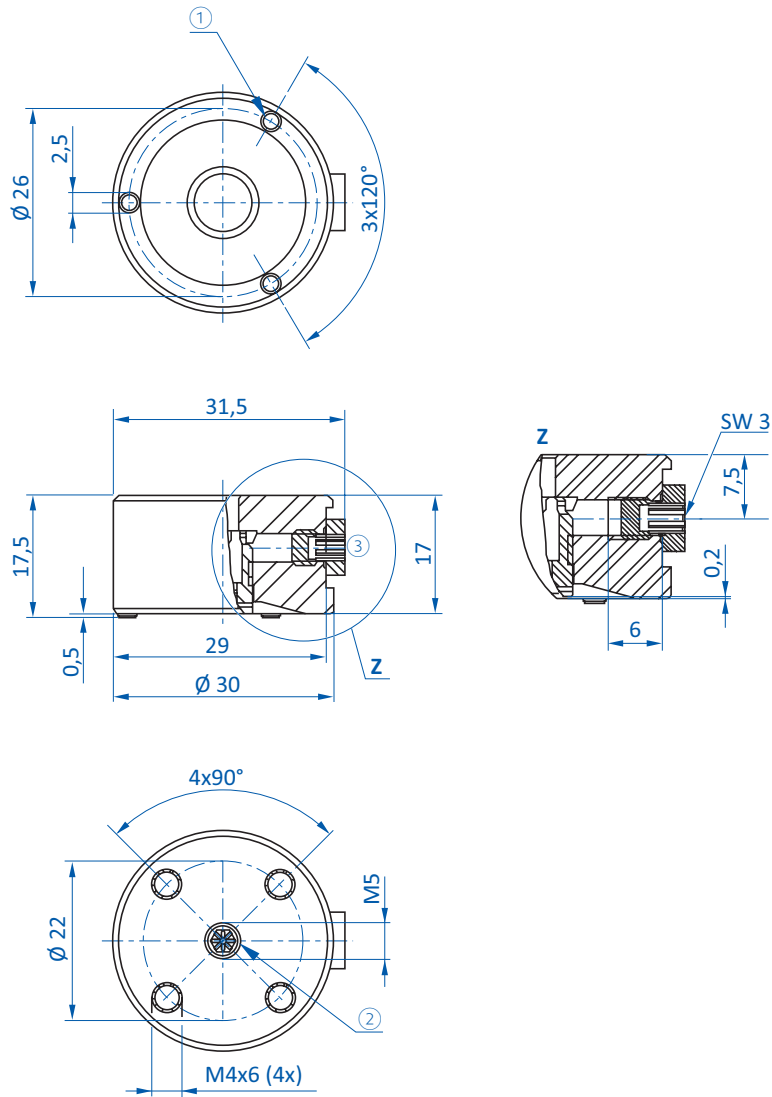

65.520

① = Pads ② = Compressed air connection ③ = Alternative compressed air connection



Dimensions

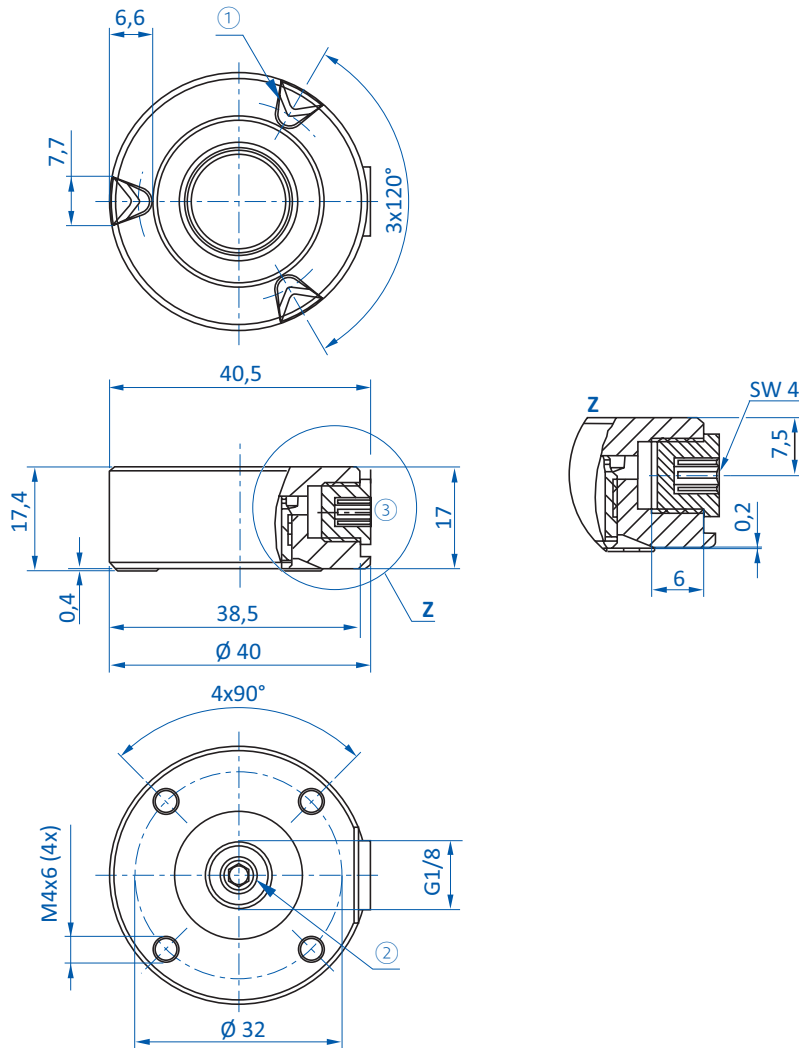

65.530

① = Pads ② = Compressed air connection ③ = Alternative compressed air connection

Continued on the next page →



# Grippers | Bernoulli vacuum cups

Bernoulli vacuum cups SX-B

## Dimensions

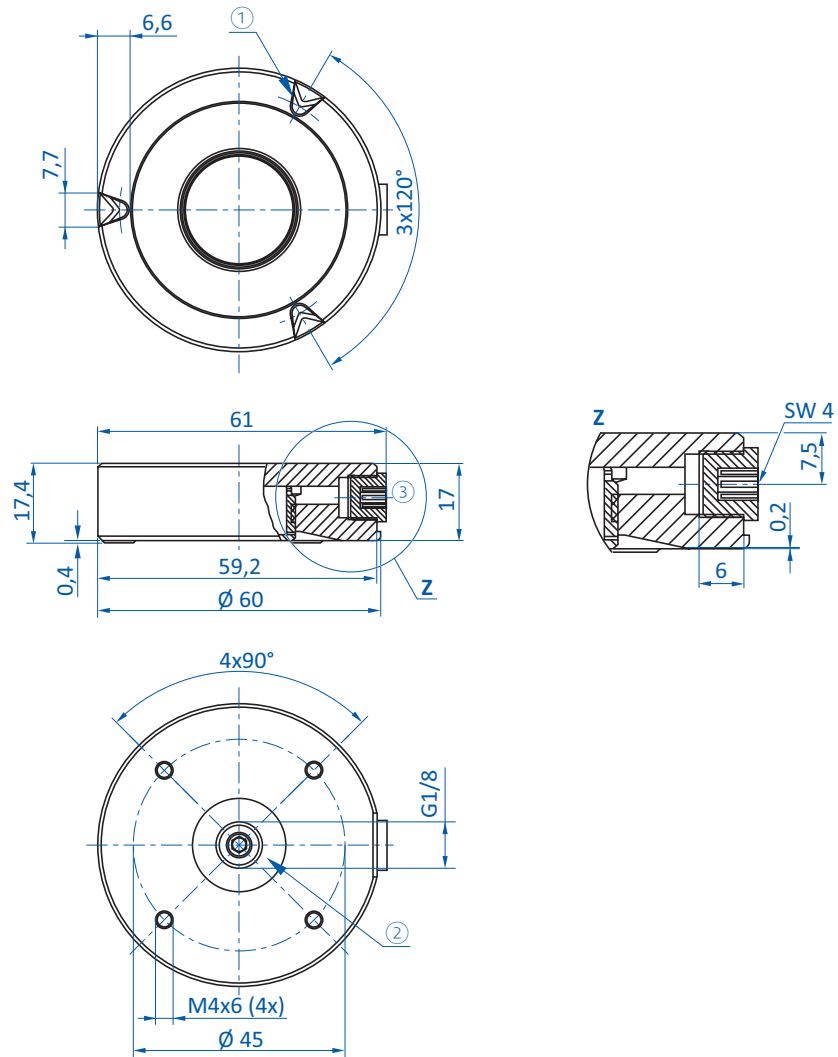

65.540

① = Pads ② = Compressed air connection ③ = Alternative compressed air connection



Diagrams

> Holding force as a function of operating pressure

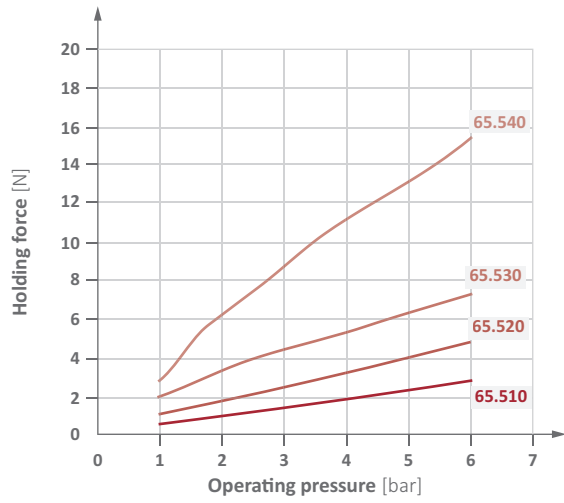

> Air consumption as a function of operating pressure

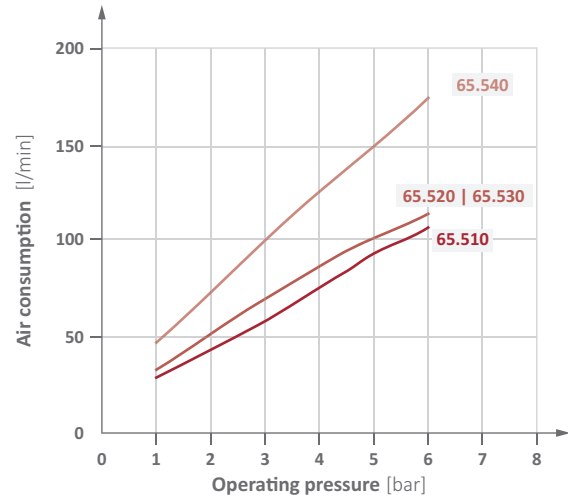



### Bernoulli vacuum cups SX-B-PK



Body and blind screws made of polyetheretherketone (PEEK), nozzle made of stainless steel

#### Product notes

- > Integrated vacuum generation on the Bernoulli principle
- > No ejector, requires compressed air only
- > Non-contact, deformation-resistant transport of thin and sensitive products
- > Compliant to FDA 21 CFR 177.2600 / FDA 21 CFR 177.2415
- > Suitable for porous products thanks to high volume flow at low vacuum level
- > Easy to install, system flexibly expandable through lateral compressed air inlets
- > Long life cycle due to maintenance-free operation
- > Only operated with oil-free, dry compressed air

#### Technical data

Item no.	Model	Operating pressure [bar (psi)]	Holding force at 5 bar (72,5 psi) [N]	Air consumption at 5 bar (72,5 psi) [l/min]	Max. particle size [µm]	Medium	Diameter [mm]	Ambient air temperature [°C (°F)]	Weight [g]	Suitable spare pads
<b>65.510-PK</b>	SX-B-PK-20	1 - 7 (14.5 - 101.5)	2.5	150	40	Compressed air	20	5 - 60 (41 - 140)	10	78.523
<b>65.520-PK</b>	SX-B-PK-30	1 - 7 (14.5 - 101.5)	3	150	40	Compressed air	30	5 - 60 (41 - 140)	20	78.524
<b>65.530-PK</b>	SX-B-PK-40	1 - 7 (14.5 - 101.5)	5.5	150	40	Compressed air	40	5 - 60 (41 - 140)	30	78.524
<b>65.540-PK</b>	SX-B-PK-60	1 - 7 (14.5 - 101.5)	12	220	40	Compressed air	60	5 - 60 (41 - 140)	70	78.524

#### Technical specifications

- > Highly resistant against diverse chemicals used in the food industry
- > Suitable for all conventional CIP (cleaning-in-place) and SIP (sterilization-in-place) processes
- > Hygienic product design enables quick and easy cleaning
- > Materials:
  - Housing: polyetheretherketone
  - Pad: silicone
  - Nozzle: stainless steel
  - Seals: fluorocautchouc
  - Blanking screw: polyetheretherketone



### Dimensions

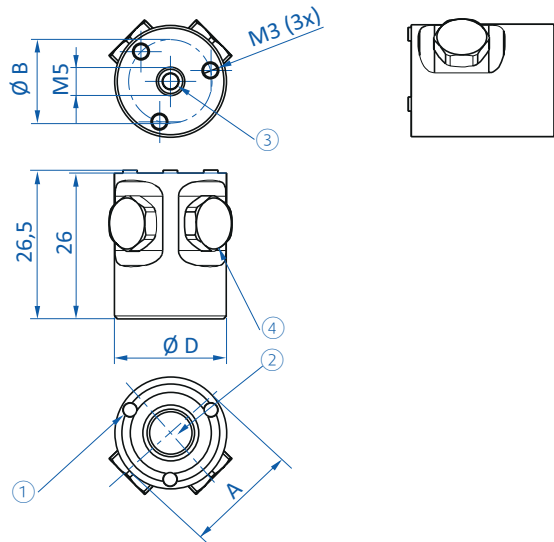

65.510-PK

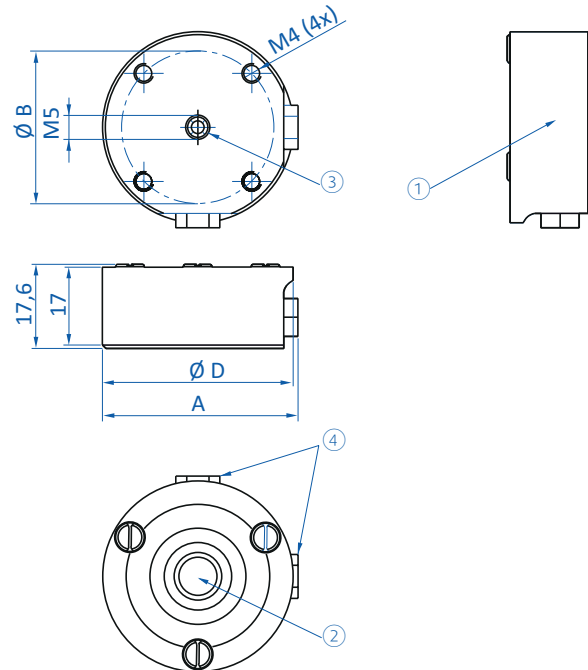

65.520-PK | 65.530-PK | 65.540-PK

① = Silicone rubber pads ② = Nozzle ③ = Compressed air connection ④ = Alternative compressed air connection

Item no.	A [mm]	Ø B [mm]	Ø D [mm]
65.510-PK	21	15	20
65.520-PK	31	22	30
65.530-PK	41	32	40
65.540-PK	61	45	60

### Diagrams

> Holding force as a function of operating pressure

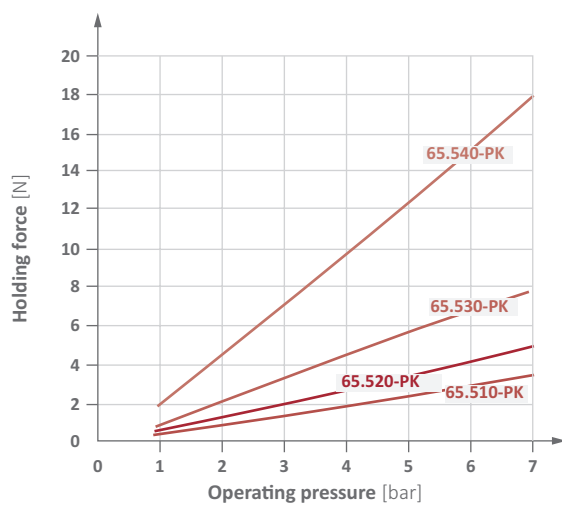

> Air consumption as a function of operating pressure

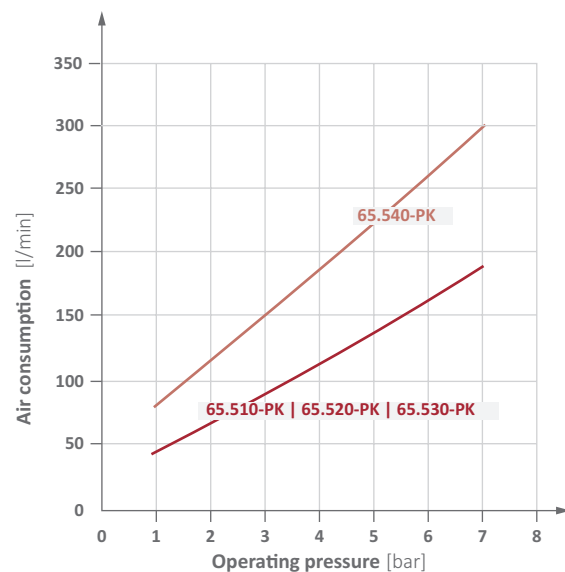





Air nippers – manual and automatic operation .....	272
Blades – manual and automatic .....	275
Air nippers – stationary .....	287
Blades – stationary .....	292
Air shears .....	300
Accessories .....	304

### Air nippers – automatic, round/square

#### AIR NIPPERS FOR PLASTIC AND METAL



Air nippers, round



Air nippers, square

#### Product notes

- > Air nippers for EOAT robot arms or cutting stations
- > Round body can be mounted in any angle position
- > Square body comes with bore holes on five surfaces
- > Rear air connection can be rotated 180°
- > GT-NS20H-1: air nipper with adjustable cutting opening
- > Pressure booster to increase cutting force optionally available

#### Technical data

Item no.	Housing	Max. cutting force [N]	Air consumption [cm <sup>3</sup> /stroke]	Operating pressure [bar (psi)]	Height blade [mm]	Connection	Accessories
<b>GT-NR3</b>	Round	294	45	4 - 5 (58 - 72.5)	7	Rc 1/8	--
<b>GT-NR5</b>	Round	392	64	4 - 5 (58 - 72.5)	7	Rc 1/8	--
<b>GT-NR7</b>	Round	490	116	4 - 5 (58 - 72.5)	9	Rc 1/8	--
<b>GT-NR10L</b>	Round	588	116	4 - 6 (58 - 87)	12	Rc 1/8	Mounting bracket: GT-NR10H Mounting bracket: GT-NR10GR Mounting bracket: GT-NR10S Mounting bracket: GT-NR10ST2 Pressure amplifier: P-10L
<b>GT-NR20</b>	Round	1,372	230	5 - 6 (72.5 - 87)	12	Rc 1/8	Mounting bracket: GT-NR20H Mounting bracket: GT-NR20S Mounting bracket: GT-NR20ST2 Pressure amplifier: P-20
<b>GT-NR30</b>	Round	2,744	584	5 - 6 (72.5 - 87)	17	Rc 1/8	Mounting bracket: GT-NR30H Mounting bracket: GT-NR30S Mounting bracket: GT-NR30ST2 Pressure amplifier: P-30
<b>GT-NR50</b>	Round	4,704	1,170	5 - 6 (72.5 - 87)	25.2	Rc 1/4	Mounting bracket: GT-NR50H Mounting bracket: GT-NR50ST2 Pressure amplifier: P-50
<b>GT-NS3</b>	Square	294	45	4 - 5 (58 - 72.5)	7	Rc 1/8	--
<b>GT-NS5</b>	Square	392	64	4 - 5 (58 - 72.5)	7	Rc 1/8	--
<b>GT-NS7</b>	Square	490	116	4 - 5 (58 - 72.5)	9	Rc 1/8	--
<b>GT-NS10L</b>	Square	588	116	4 - 6 (58 - 87)	12	Rc 1/8	Pressure amplifier: P-10L
<b>GT-NS20</b>	Square	1,372	230	5 - 6 (72.5 - 87)	12	Rc 1/8	Pressure amplifier: P-20
<b>GT-NS20H-1</b>	Automatic, square with adjustable cutting opening	1,372	230	5 - 6 (72.5 - 87)	12	Rc 1/8	Pressure amplifier: P-20
<b>GT-NS30</b>	Square	2,744	584	5 - 6 (72.5 - 87)	17	Rc 1/8	Pressure amplifier: P-30



### Application example

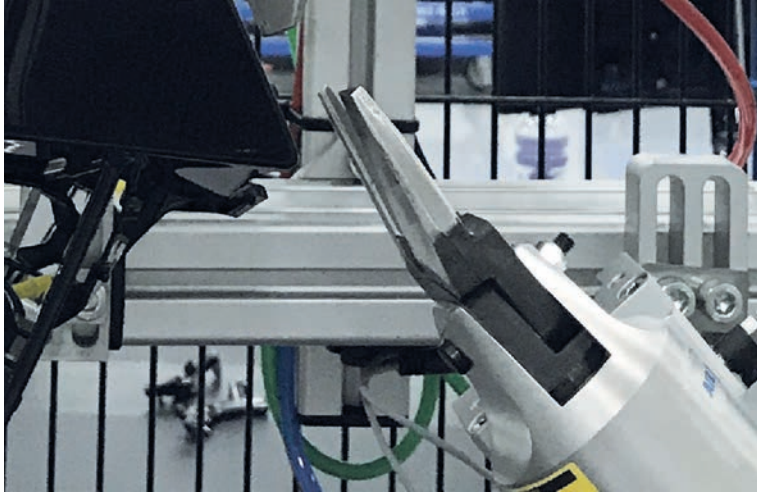

### Dimensions

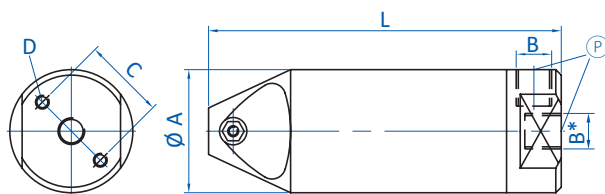

GT-NR3 | GT-NR5 | GT-NR7 | GT-NR10L |  
GT-NR20 | GT-NR30 | GT-NR50

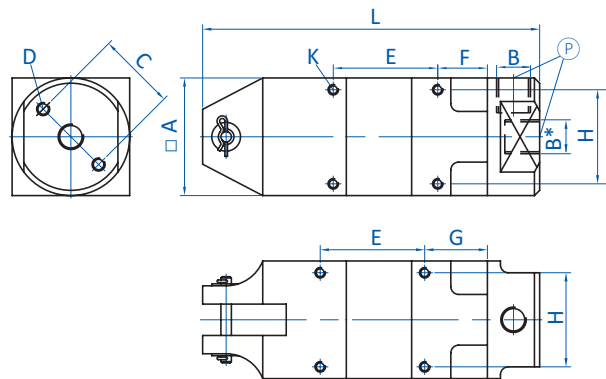

GT-NS3 | GT-NS5 | GT-NS7 | GT-NS10L |  
GT-NS20 | GT-NS20H-1 | GT-NS30

Ⓟ = Compressed air connection \* = compatible with G threads

Item no.	A [mm]	B	C [mm]	D	E [mm]	F [mm]	G [mm]	H [mm]	K	L [mm]
GT-NR3	23	Rc 1/8	17	M3	--	--	--	--	--	110
GT-NR5	30	Rc 1/8	20	M4	--	--	--	--	--	94
GT-NR7	34	Rc 1/8	22	M4	--	--	--	--	--	113
GT-NR10L	36	Rc 1/8	24	M4	--	--	--	--	--	113
GT-NR20	45	Rc 1/8	30	M5	--	--	--	--	--	129
GT-NR30	56	Rc 1/8	40	M6	--	--	--	--	--	165
GT-NR50	75	Rc 1/4	50	M8	--	--	--	--	--	222
GT-NS3	23	Rc 1/8	17	M3x8	40	19	24	19	M3x3.5	110
GT-NS5	30	Rc 1/8	20	M4x10	30	14	19	24	M3x5	94
GT-NS7	36	Rc 1/8	24	M4x10	30	18	23	28	M4x5.5	113
GT-NS10L	36	Rc 1/8	24	M4x10	30	18	23	28	M4x5.5	113
GT-NS20	45	Rc 1/8	30	M5x12	40	19	24	36	M4x7	129
GT-NS20H-1	45	Rc 1/8	30	M5x12	40	19	24	36	M4x7	129
GT-NS30	56	Rc 1/8	40	M6x12	60	20	30	46	M5x10	170



# Nipper technology | Air nippers – manual and automatic operation

## Air nippers for manual operation

### Air nippers for manual operation



AIR NIPPERS FOR PLASTIC AND METAL

#### Product notes

- > Manually operated air nippers with safety lever
- > Round shaped body with knurling for safe grip
- > GT-N20, N30 and N50 come with stopcock to lock compressed air supply
- > Pressure booster to increase cutting force optionally available

#### Technical data

Item no.	Max. cutting force [N]	Air consumption [cm <sup>3</sup> /stroke]	Operating pressure [bar (psi)]	Height blade [mm]	Connection	Weight [g]	Pressure amplifier	Dimensions	
								∅ A [mm]	L [mm]
GT-N3	294	45	4 - 5 (58 - 72.5)	7	Rc 1/4	100	--	23	112
GT-N5	392	64	4 - 5 (58 - 72.5)	7	Rc 1/4	140	--	30	103
GT-N7	490	116	4 - 5 (58 - 72.5)	9	Rc 1/4	190	--	34	123
GT-N10	588	116	4 - 6 (58 - 87)	9	Rc 1/4	200	--	34	132
GT-N12	735	116	5 - 6 (72.5 - 87)	12	Rc 1/4	220	P-10L	36	132
GT-N20	1,372	230	5 - 6 (72.5 - 87)	12	Rc 1/4	430	P-20	45	156
GT-N30	2,744	584	5 - 6 (72.5 - 87)	17	Rc 1/4	685	P-30	56	193
GT-N50	4,704	1,220	5 - 6 (72.5 - 87)	25.2	Rc 1/4	1,220	P-50	75	237

#### Dimensions

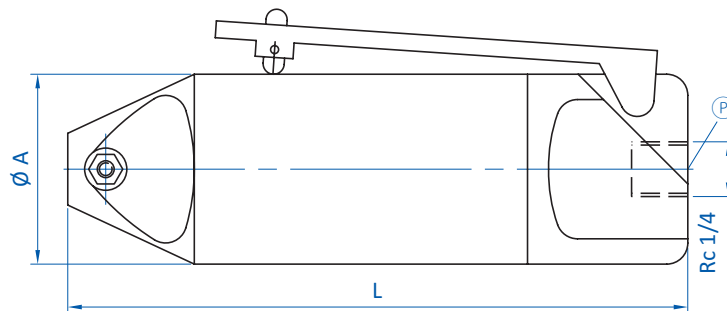

⊕ = Compressed air connection \* = compatible with G threads



### Blades for plastic, straight



#### Product notes

- > Blades with straight cutting edge for clean cuts
- > AJ, LAB2 and AB39: standard blade
- > AJL: blade extra long

#### Technical data

Item no.	Material	Max. cutting thickness [mm]		Design	Weight [g]	Air nippers
		PP/PE	ABS			
<b>N3AJ</b>	Ferrous alloy	2	--	straight	40	GT-N3 GT-NR3 GT-NS3
<b>N10LAB2</b>	Ferrous alloy	4	2.6	straight	120	GT-NR10L GT-NS10L
<b>N20AJ</b>	Ferrous alloy	7	5	straight	125	GT-N20 GT-NS20 GT-NR20
<b>N20AB39</b>	Ferrous alloy	7	5	straight	185	GT-N20 GT-NS20
<b>N20AJL</b>	Ferrous alloy	7	5	straight, blade extra long	230	GT-N20 GT-NR20 GT-NS20
<b>N30AJ</b>	Ferrous alloy	10	6.5	straight	370	GT-N30 GT-NR30 GT-NS30
<b>N30AJL</b>	Ferrous alloy	10	6.5	straight, blade extra long	470	GT-N30 GT-NR30 GT-NS30
<b>N50AJL</b>	Ferrous alloy	15	8	straight, blade extra long	1,430	GT-N50 GT-NR50

Continued on the next page →



### Dimensions

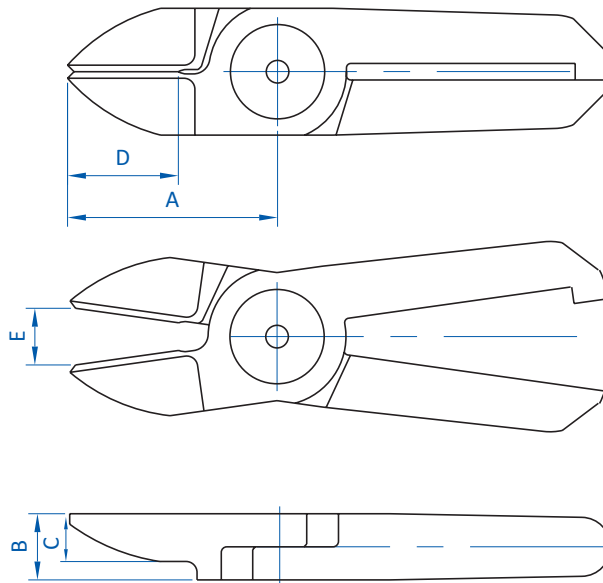

Item no.	A [mm]	B [mm]	C [mm]	D [mm]	E [mm]
N3AJ	24	7	4	12	5.5
N10LAB2	61	12	7	36	10
N20AJ	35	12	8	18	11
N20AB39	61	12	7	36	14
N20AJL	65	12	7	20	16
N30AJ	52	17	8	28	11
N30AJL	75	17	8	25	19
N50AJL	110	25	15	35	26



### Blades for plastic, angled



Model PF

#### Product notes

- > Blades with angled cutting edge
- > Model PF: blades with deep angle
- > All other blades with standard angle

#### Technical data

Item no.	Material	Max. cutting thickness [mm]		Design	Weight [g]	Air nippers
		PP/PE	ABS			
<b>N3AP</b>	Ferrous alloy	2	--	angled	35	GT-N3, GT-NR3, GT-NS3
<b>N5AP</b>	Ferrous alloy	2	--	angled	40	GT-N5, GT-NR5, GT-NS5
<b>N7AP</b>	Ferrous alloy	3	2	angled	80	GT-N7, GT-NR7, GT-NS7
<b>N7PF</b>	Ferrous alloy	3	2	angled	80	GT-N7, GT-NR7, GT-NS7
<b>N10AP</b>	Ferrous alloy	4	2.6	angled	85	GT-N10
<b>N10LAB152</b>	Ferrous alloy	4	2.6	angled	165	GT-NR10L
<b>N10LAP</b>	Ferrous alloy	4	2.6	angled	120	GT-NR10L, GT-NS10L
<b>N10LPF</b>	Ferrous alloy	4	2.6	angled	120	GT-NR10L, GT-NS10L
<b>N12AP</b>	Ferrous alloy	4.5	4	angled	135	GT-N12
<b>N20AA239</b>	Ferrous alloy	6	4	angled	195	GT-N20, GT-NS20, GT-NR20
<b>N20AA27</b>	Ferrous alloy	6.5	4.5	angled	145	GT-N20, GT-NS20, GT-NR20
<b>N20AB360</b>	Ferrous alloy	7	5	angled	185	GT-NS20, GT-N20, GT-NR20
<b>N20AP</b>	Ferrous alloy	7	5	angled	125	GT-NS20, GT-N20, GT-NR20
<b>N20PF</b>	Ferrous alloy	7	5	angled	130	GT-N20, GT-NR20, GT-NS20
<b>N30AA114</b>	Ferrous alloy	10	6.5	angled	385	GT-N30, GT-NR30, GT-NS30
<b>N30AP</b>	Ferrous alloy	10	6.5	angled	380	GT-N30, GT-NR30, GT-NS30
<b>N30PF</b>	Ferrous alloy	10	6.5	angled	390	GT-N30, GT-NR30, GT-NS30
<b>N50AB</b>	HSS steel	15	8	angled	1,100	GT-N50, GT-NR50
<b>N50ABH41</b>	HSS steel	18	8	angled	1,000	GT-N50, GT-NR50

Continued on the next page →



### Dimensions

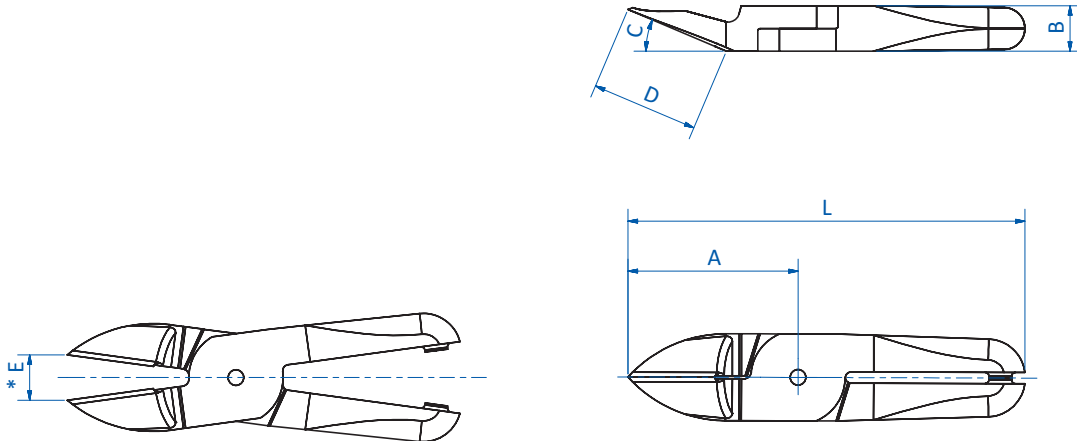

N3AP | N5AP | N7AP | N7PF | N10AP | N10LAB152 | N10LAP | N10LPF | N12AP | N20AA239 | N20AA27 | N20AB360 | N20AP | N20PF | N30AP | N30PF

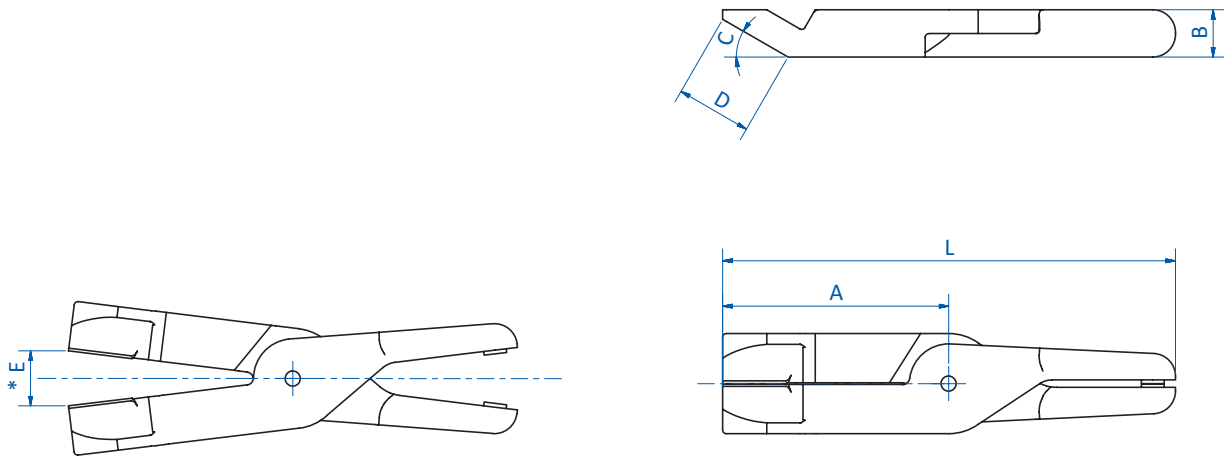

N30AA114 | N50AB | N50ABH41

\* = width of opening

Item no.	A [mm]	B [mm]	C [°]	D [mm]	E [mm]	L [mm]
N3AP	24	7	15	11.5	4	64
N5AP	24	7	15	11.5	4	64
N7AP	27	9	30	11.5	4	81
N7PF	27	9	40	10.5	4	81
N10AP	27	9	30	11.5	5	91
N10LAB152	61	12	15	35	10	115
N10LAP	35	12	15	16	5	89
N10LPF	35	12	40	13.5	5	89
N12AP	35	12	15	16	5	105
N20AA239	52.3	12	40	27	14	112.3
N20AA27	45	12	23	25	12	105
N20AB360	61	12	15	35	16	121
N20AP	35	12	15	16	11	95
N20PF	35	12	40	13.5	11	95
N30AA114	76.3	17	30	50	20	160.3
N30AP	66	17	15	38	16	150
N30PF	58	17	30	25	15	142
N50AB	90	25	30	33.5	21	210
N50ABH41	119.6	25	30	40	29	239.6





## Blades for plastic, laterally facing



### Product notes

- > Blades with 90° bend cutting edge for sprues in restricted spaces, e.g. sprues of two opposing parts
- > AML: blade with left orientation
- > AMR: blade with right orientation

### Technical data

Item no.	Material	Max. cutting thickness [mm]		Design	Weight [g]	Air nippers
		PP / PE	ABS			
<b>N20AML</b>	Ferrous alloy	10x1.5	8x1	left orientation	270	GT-N20, GT-NR20, GT-NS20
<b>N20AMR</b>	Ferrous alloy	10x1.5	8x1	right orientation	270	GT-NR20, GT-NS20, GT-N20
<b>N30AML</b>	Ferrous alloy	15x2	10x1.5	left orientation	520	GT-N30, GT-NR30, GT-NS30
<b>N30AMR</b>	Ferrous alloy	15x2	10x1.5	right orientation	520	GT-N30, GT-NR30, GT-NS30

### Dimensions

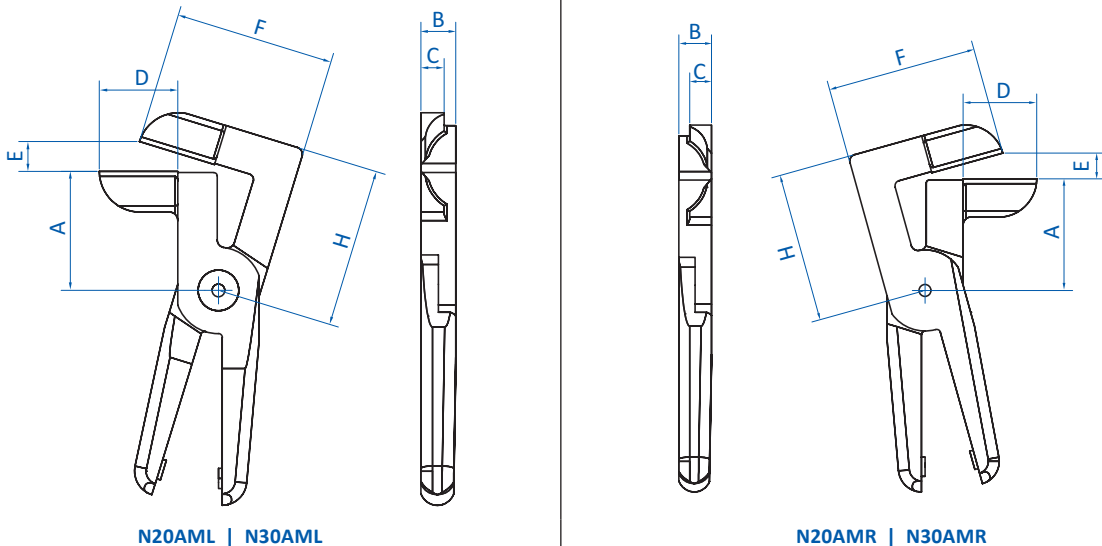

Item no.	A [mm]	B [mm]	C [mm]	D [mm]	E [mm]	F [mm]	H [mm]
<b>N20AML</b>	41	12	8	27	9.5	55	55
<b>N20AMR</b>	41	12	8	27	9.5	55	55
<b>N30AML</b>	39	17	10	36	13	68	55
<b>N30AMR</b>	39	17	10	36	13	68	55



### Blades for plastic, L-shape



#### Product notes

> Long blades with 90° angle for clean cuts

#### Technical data

Item no.	Material	Max. cutting thickness [mm]		Design	Weight [g]	Air nippers
		PP/PE	ABS			
<b>N20AL</b>	Ferrous alloy	7	5	L-shape	135	GT-N20 GT-NR20 GT-NS20
<b>N30AL525</b>	Ferrous alloy	10	6.5	L-shape	395	GT-N30 GT-NR30 GT-NS30

#### Dimensions

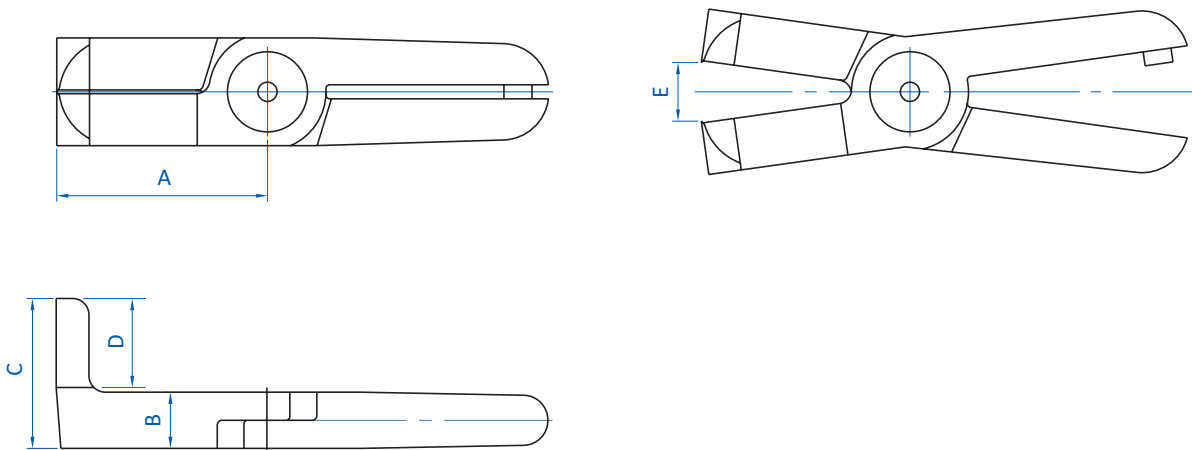

Item no.	A [mm]	B [mm]	C [mm]	D [mm]	E [mm]
<b>N20AL</b>	45	12	32	18	12
<b>N30AL525</b>	60	17	62	36	16



## Singular blades for plastic, Z-shape



### Product notes

> Blades with offset cutting edge for overcoming obstacles or for narrow sprues

### Technical data

Item no.	Material	Max. cutting thickness [mm]		Design	Weight [g]	Air nippers
		PP/PE	ABS			
N20AH	Ferrous alloy	7	5	Z-shape	240	GT-N20 GT-NR20 GT-NS20
N30AH	Ferrous alloy	10	6.5	Z-shape	450	GT-N30 GT-NR30 GT-NS30

### Dimensions

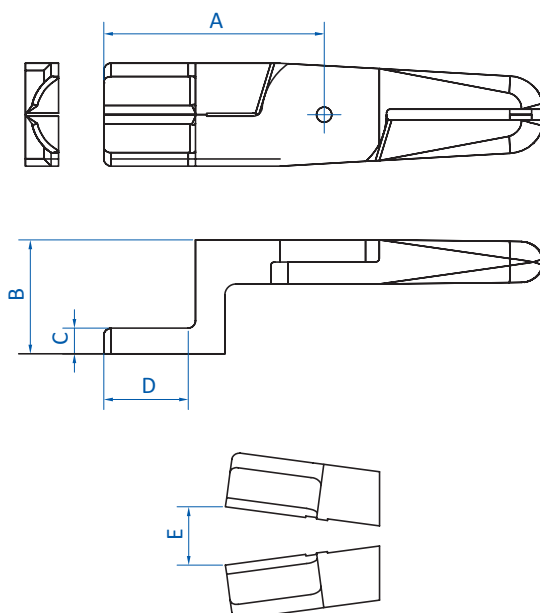

Item no.	A [mm]	B [mm]	C [mm]	D [mm]	E [mm]
N20AH	60	31	7	23	16
N30AH	80	65	8	34	22



### Blades for plastic, nipper style



#### Product notes

> Blades, nipper style, for cutting applications

#### Technical data

Item no.	Material	Max. cutting thickness [mm]		Design	Weight [g]	Air nippers
		PP/PE	ABS			
N3AE	Ferrous alloy	2	--	nipper style	35	GT-N3, GT-NR3, GT-NS3
N5AE	Ferrous alloy	2	--	nipper style	40	GT-N5, GT-NR5, GT-NS5
N7AE	Ferrous alloy	3	2	nipper style	85	GT-N7, GT-NR7, GT-NS7
N10AE	Ferrous alloy	4	2.6	nipper style	120	GT-N10, GT-NR10L, GT-NS10L
N20AE	Ferrous alloy	7	5	nipper style	135	GT-N20, GT-NR20, GT-NS20
N30AE	Ferrous alloy	10	6.5	nipper style	395	GT-N30, GT-NR30, GT-NS30
N50AE	Ferrous alloy	12	6.5	nipper style	1,000	GT-N50, GT-NR50

#### Dimensions

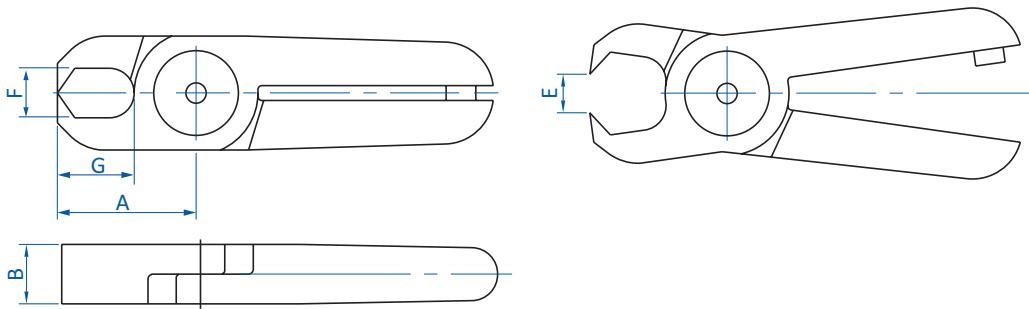

Item no.	A [mm]	B [mm]	F x G [mm]	E [mm]
N3AE	20	7	6x6.6	3.5
N5AE	20	7	6x6.6	3.5
N7AE	26	9	8x8.8	4
N10AE	26	9	8x15.5	5
N20AE	28	12	10x15.5	8
N30AE	45	17	13x28	12
N50AE	128	25	25x90	30



## Blades for metal, straight



Model BJ



Model N20BFB

### Product notes

- > Straight blades with one unbeveled cutting edge using the anvil principle or with carbide tips for extra strength
- > BJ: blades using anvil principle to cut thin wire
- > N20BFB and N50AS: blades in clipper type shape with carbide tips to cut thicker wire or thin pipes

### Technical data

Item no.	Material	Max. cutting thickness [mm]			Design	Weight [g]	Air nippers
		Copper wire	Steel wire	Piano wire			
<b>N3BJ</b>	Ferrous alloy	1	0.5	--	straight	35	GT-N3 GT-NR3 GT-NS3
<b>N5BJ</b>	Ferrous alloy	1	0.5	--	straight	40	GT-N5 GT-NR5 GT-NS5
<b>N7BJ</b>	Ferrous alloy	1.6	1	--	straight	75	GT-N7 GT-NR7 GT-NS7
<b>N20BFB</b>	Sintered alloy	2.6	2	1.2	straight	150	GT-N20 GT-NR20 GT-NS20
<b>N50AS</b>	Ferrous alloy	5.5	4.5	--	straight	950	GT-N50 GT-NR50

Continued on the next page →



## Dimensions

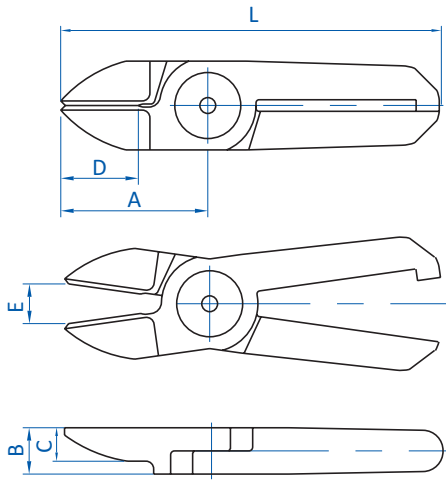

N3BJ | N5BJ | N7BJ

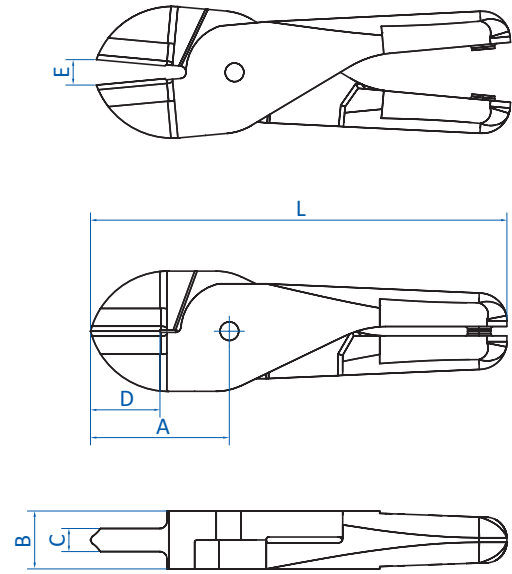

N20BFB | N50AS

Item no.	A [mm]	B [mm]	C [mm]	D [mm]	E [mm]	L [mm]
N3BJ	24	7	5.8	13	5	64
N5BJ	24	7	5.8	13	4	64
N7BJ	27	9	7.5	13	5	81
N20BFB	35	12	5	17	8	95
N50AS	60	25	10	30	11	180



## Blades for metal, angled



## Product notes

- > Blades with a beveled cutting edge using the anvil principle
- > N30BBB and N50BBB: blades with carbide tips to cut hard wire such as high steel wire or piano wire
- > N50BBB: blades in clipper type shape with carbide tips to cut thicker wire or thin pipes

## Technical data

Item no.	Material	Max. cutting thickness [mm]			Design	Weight [g]	Air nippers
		Copper wire	Steel wire	Piano wire			
N3AS	Ferrous alloy	1	0.5	--	angled	35	GT-N3, GT-NR3, GT-NS3
N3HS	HSS steel	1	0.5	0.2	angled	35	GT-N3, GT-NR3, GT-NS3
N5AS	Ferrous alloy	1	0.5	--	angled	40	GT-N5, GT-NR5, GT-NS5
N5HS	HSS steel	1	0.5	0.3	angled	40	GT-N5, GT-NR5, GT-NS5
N7AS	Ferrous alloy	1.6	1	--	angled	80	GT-N7, GT-NR7, GT-NS7
N7HS	HSS steel	1.6	1	0.5	angled	80	GT-N7, GT-NR7, GT-NS7
N10AS	Ferrous alloy	1.8	1.2	--	angled	85	GT-N10
N10HS	HSS steel	1.8	1.2	--	angled	85	GT-N10
N10LAS	Ferrous alloy	1.8	1.2	--	angled	120	GT-NR10L, GT-NS10L
N12AS	Ferrous alloy	2.3	1.7	--	angled	135	GT-N12
N12HS	HSS steel	2.3	1.7	--	angled	95	GT-N12
N20AS	Ferrous alloy	2.6	2	--	angled	140	GT-N20, GT-NR20, GT-NS20
N20HS	HSS steel	2.6	2	1	angled	135	GT-N20, GT-NR20, GT-NS20
N30AS	Ferrous alloy	3.3	2.8	--	angled	370	GT-N30, GT-NR30, GT-NS30
N30BBB	Sintered alloy	3.3	2.8	1.2	angled	365	GT-N30, GT-NR30, GT-NS30
N50BBB	Sintered alloy	5.5	4.5	2	angled	955	GT-N50, GT-NR50

Continued on the next page



## Dimensions

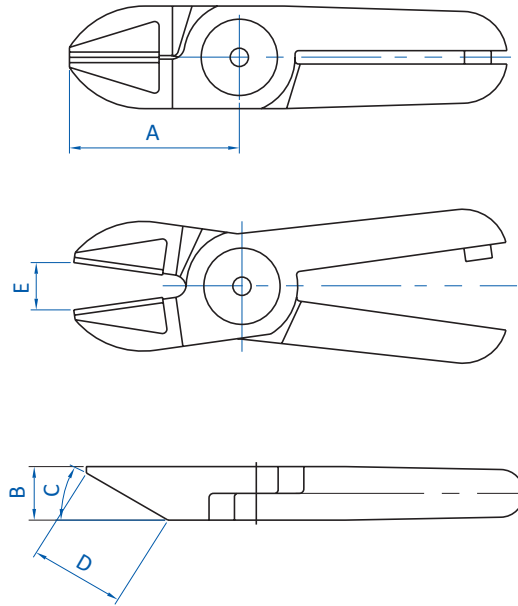

Item no.	A [mm]	B [mm]	C [°]	D [mm]	E [mm]
N3AS	24	7	25	12	4
N3HS	24	7	25	12	4
N5AS	24	7	25	12	4
N5HS	24	7	25	12	4
N7AS	27	9	30	13.5	4
N7HS	27	9	30	13.5	4
N10AS	27	9	30	13.5	5
N10HS	27	9	30	13.5	5
N10LAS	35	12	30	20	5
N12AS	35	12	30	20	5
N12HS	35	12	30	20	9
N20AS	35	12	30	20	9
N20HS	26	12	40	10	7
N30AS	43	17	30	25	9
N30BBB	36	17	40	18	7
N50BBB	46	25	35	19	9





### Stationary air nippers – horizontal without stroke

**AIR NIPPERS FOR PLASTIC AND METAL**



#### Product notes

- > Nippers, lightweight and compact, for easy installation in restricted spaces
- > To be used with cutting stations or automated equipment
- > Mounting holes at three sides
- > Max. blade opening and nipper length "K" refer to blades with index "AJ" resp. "RAJ"
- > Blades are not included in the scope of delivery. Please order separately.

#### Technical data

Item no.	Max. cutting force [N]	Air consumption [cm <sup>3</sup> /stroke]	Operating pressure [bar (psi)]	Max. opening for cutting [mm]	Pipe connection [mm]	Weight [g]
GT-NF05	343	43	4 - 5 (58 - 72.5)	4	4	101
GT-NF10	490	63	4 - 5 (58 - 72.5)	6	4	143
GT-NF15	784	128	4 - 5 (58 - 72.5)	8	4	219

#### Dimensions

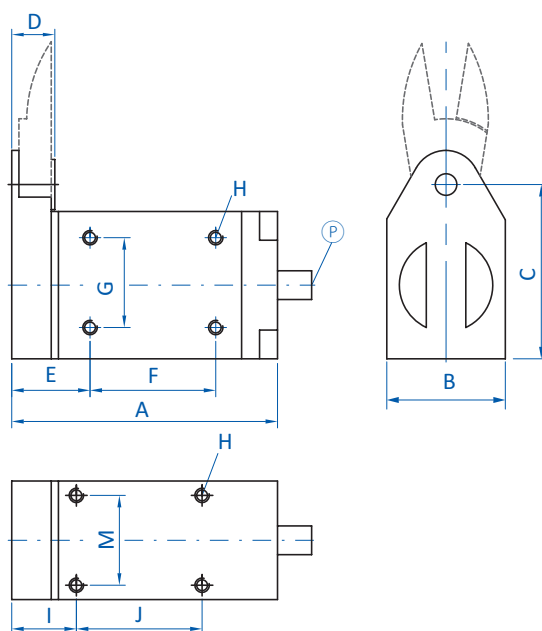

Ⓟ = Compressed air connection 4 mm x 2.5 mm

Item no.	A [mm]	B [mm]	C [mm]	D [mm]	E [mm]	F [mm]	G [mm]	H	I [mm]	J [mm]	M [mm]
GT-NF05	59.9	23	39.5	8.6	25.9	17	26	M3	21.9	17	18
GT-NF10	65.1	28	43.5	8.8	27.1	20	30	M3.5	23.1	20	22
GT-NF15	73	33	48.5	10.2	29	25	34	M4	25	25	26



### Stationary air nippers – horizontal with stroke



#### Product notes

- > Nippers, lightweight and compact, for easy assembly in restricted spaces
- > To be used with cutting stations or automated equipment
- > Stroke single-acting with return spring
- > Horizontal, adjustable stroke enables cutting flush to the workpiece
- > Connection via hose nipples or quick fittings
- > Version (-R): push stroke models
- > All others: pull stroke models
- > Max. opening width and length "K" refer to blades with index "AJ" or "RAJ"
- > Blades are not included in the scope of delivery. Please order separately.

#### Technical data

Item no.	Max. cutting force [N]	Air consumption [cm <sup>3</sup> /stroke]	Max. stroke [mm]	Effective direction	Operating pressure [bar (psi)]	Pipe connection	Weight [g]
GT-NY05	343	48	3	Pull	4 - 5 (58 - 72.5)	Hose nipple Ø 2,5 [mm]	155
GT-NY05R	343	48	3	Push	4 - 5 (58 - 72.5)	Hose nipple Ø 2,5 [mm]	155
GT-NY05-4	343	48	3	Pull	4 - 5 (58 - 72.5)	Quick connect fitting Ø 4x2,5 [mm]	155
GT-NY05R-4	343	48	3	Push	4 - 5 (58 - 72.5)	Quick connect fitting Ø 4x2,5 [mm]	155
GT-NY10	490	68	3	Pull	4 - 5 (58 - 72.5)	Hose nipple Ø 2,5 [mm]	210
GT-NY10R	490	68	3	Push	4 - 5 (58 - 72.5)	Hose nipple Ø 2,5 [mm]	210
GT-NY10-4	490	68	3	Pull	4 - 5 (58 - 72.5)	Quick connect fitting Ø 4x2,5 [mm]	210
GT-NY10R-4	490	68	3	Push	4 - 5 (58 - 72.5)	Quick connect fitting Ø 4x2,5 [mm]	210
GT-NY15	784	136	3	Pull	4 - 5 (58 - 72.5)	Hose nipple Ø 2,5 [mm]	319
GT-NY15R	784	136	3	Push	4 - 5 (58 - 72.5)	Hose nipple Ø 2,5 [mm]	319
GT-NY15-4	784	136	3	Pull	4 - 5 (58 - 72.5)	Quick connect fitting Ø 4x2,5 [mm]	319
GT-NY15R-4	784	136	3	Push	4 - 5 (58 - 72.5)	Quick connect fitting Ø 4x2,5 [mm]	319
GT-NY25	980	184	5	Pull	5 - 6 (72.5 - 87)	Hose nipple Ø 4 [mm]	580
GT-NY25R	980	184	5	Push	5 - 6 (72.5 - 87)	Hose nipple Ø 4 [mm]	580
GT-NY25-6	980	184	5	Pull	5 - 6 (72.5 - 87)	Quick connect fitting Ø 6x4 [mm]	580
GT-NY25R-6	980	184	5	Push	5 - 6 (72.5 - 87)	Quick connect fitting Ø 6x4 [mm]	580



### Dimensions

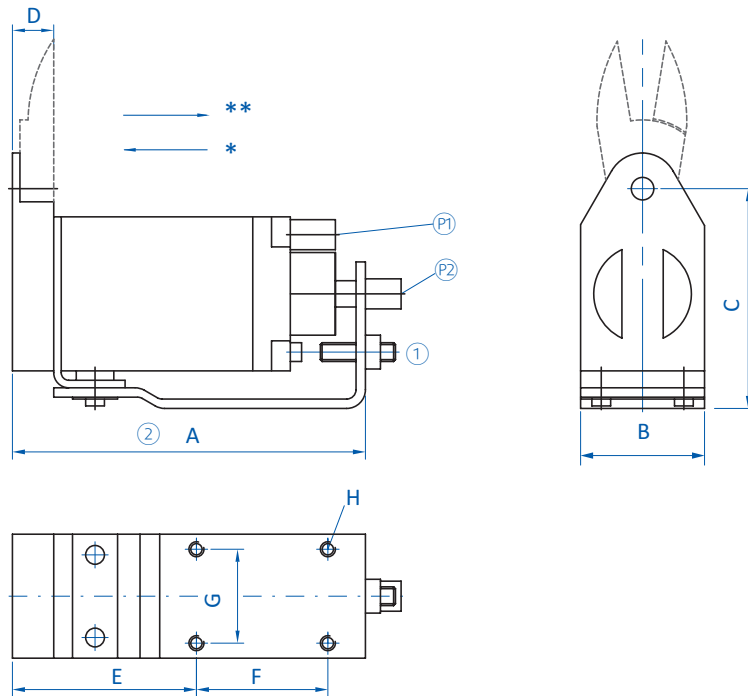

P1 = Compressed air connection for cutting   P2 = Compressed air connection for stroke   \* = Push stroke (Version -R)   \*\* = Pull stroke  
 1 = Stroke adjustment  
 2 = Models NY-R: A = Distance from start of nipper to cutting position / Models NY: A = Distance from start of nipper to starting position

Item no.	A [mm]	B [mm]	C [mm]	D [mm]	E [mm]	F [mm]	G [mm]	H
GT-NY05	75.9	23	48	8.6	41	25	15	M4
GT-NY05R	75.9	23	48	8.6	41	25	15	M4
GT-NY05-4	75.9	23	48	8.6	41	25	15	M4
GT-NY05R-4	75.9	23	48	8.6	41	25	15	M4
GT-NY10	82.1	28	52	8.8	42	30	20	M4
GT-NY10R	82.1	28	52	8.8	42	30	20	M4
GT-NY10-4	82.1	28	52	8.8	42	30	20	M4
GT-NY10R-4	82.1	28	52	8.8	42	30	20	M4
GT-NY15	93	33	58	10	48	35	25	M4
GT-NY15R	93	33	58	10	48	35	25	M4
GT-NY15-4	93	33	58	10	48	35	25	M4
GT-NY15R-4	93	33	58	10	48	35	25	M4
GT-NY25	109	42	69	13	55	40	30	M5
GT-NY25R	109	42	69	13	55	40	30	M5
GT-NY25-6	109	42	69	13	55	40	30	M5
GT-NY25R-6	109	42	69	13	55	40	30	M5



# Nipper technology | Air nippers – stationary

Nippers for plastics – vertical, with stroke

## Nippers for plastics – vertical, with stroke



**ADJUSTABLE BLADE OPENING AND  
REVERSABLE BLADES**

### Product notes

- > Nippers, lightweight and compact, for easy assembly in confined spaces
- > To be used in cutting stations
- > Adjustable horizontal stroke and maximum blade opening
- > Blades can be reversed to enable cutting flush to the workpiece
- > Max. opening width "I" refers to blades with index "AJ"
- > Blades are not included in the scope of delivery. Please order separately.

### Technical data

Item no.	Max. cutting force [N]	Air consumption [cm <sup>3</sup> /stroke]	Max. opening for cutting [mm]	Stroke [mm]	Effective direction	Operating pressure [bar (psi)]	Pipe connection with hose nipple [mm]	Pipe connection with quick connect fittings [mm]	Pipe connection	Weight [g]
GT-NT03	147	27	1.5 - 3	0 - 3	Pull	4 - 5 (58 - 72.5)	2.5	--	Hose nipple Ø 2,5 [mm]	178
GT-NT03R	147	27	1.5 - 3	0 - 3	Push	4 - 5 (58 - 72.5)	2.5	--	Hose nipple Ø 2,5 [mm]	178
GT-NT03-4	147	27	1.5 - 3	0 - 3	Pull	4 - 5 (58 - 72.5)	--	4x2,5	Quick connect fitting Ø 4x2,5 [mm]	178
GT-NT03R-4	147	27	1.5 - 3	0 - 3	Push	4 - 5 (58 - 72.5)	--	4x2,5	Quick connect fitting Ø 4x2,5 [mm]	178
GT-NT05	196	47	3 - 6	0 - 3	Pull	4 - 5 (58 - 72.5)	2.5	--	Hose nipple Ø 2,5 [mm]	325
GT-NT05R	196	47	3 - 6	0 - 3	Push	4 - 5 (58 - 72.5)	2.5	--	Hose nipple Ø 2,5 [mm]	325
GT-NT05-4	196	47	3 - 6	0 - 3	Pull	4 - 5 (58 - 72.5)	--	4x2,5	Quick connect fitting Ø 4x2,5 [mm]	325
GT-NT05R-4	196	47	3 - 6	0 - 3	Push	4 - 5 (58 - 72.5)	--	4x2,5	Quick connect fitting Ø 4x2,5 [mm]	325
GT-NT10	441	82	4 - 7	0 - 3	Pull	4 - 5 (58 - 72.5)	2.5	--	Hose nipple Ø 2,5 [mm]	515
GT-NT10R	441	82	4 - 7	0 - 3	Push	4 - 5 (58 - 72.5)	2.5	--	Hose nipple Ø 2,5 [mm]	515
GT-NT10-6	441	82	4 - 7	0 - 3	Pull	4 - 5 (58 - 72.5)	--	6x4	Quick connect fitting Ø 6x4 [mm]	515
GT-NT10R-6	441	82	4 - 7	0 - 3	Push	4 - 5 (58 - 72.5)	--	6x4	Quick connect fitting Ø 6x4 [mm]	515
GT-NT20	931	203	4.5 - 9	0 - 8	Pull	5 - 6 (72.5 - 87)	4	--	Hose nipple Ø 4 [mm]	930
GT-NT20R	931	203	4.5 - 9	0 - 8	Push	5 - 6 (72.5 - 87)	4	--	Hose nipple Ø 4 [mm]	930
GT-NT20-6	931	203	4.5 - 9	0 - 8	Pull	5 - 6 (72.5 - 87)	--	6x4	Quick connect fitting Ø 6x4 [mm]	930
GT-NT20R-6	931	203	4.5 - 9	0 - 8	Push	5 - 6 (72.5 - 87)	--	6x4	Quick connect fitting Ø 6x4 [mm]	930



### Dimensions

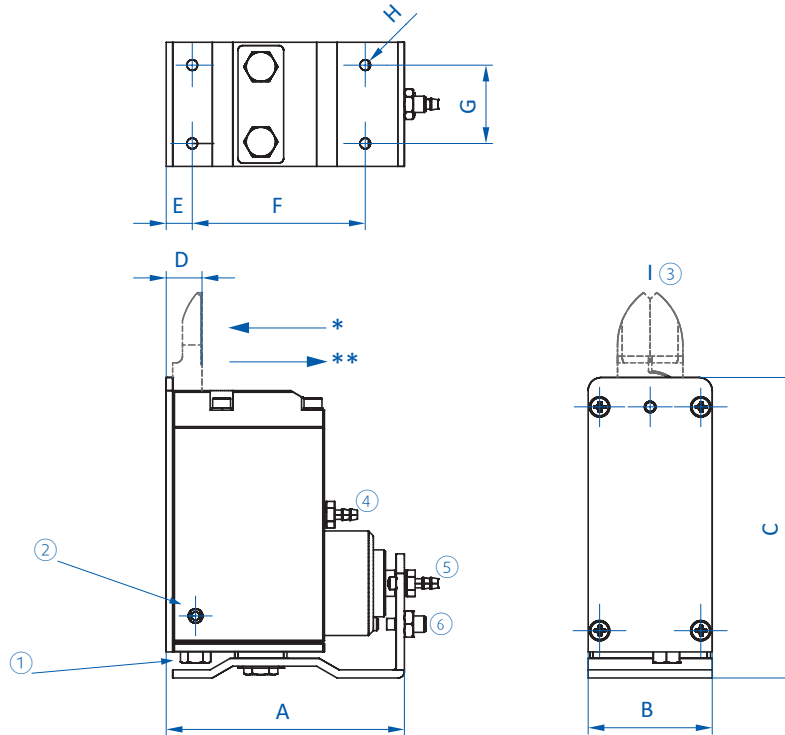

\* = Push stroke \*\* = Pull stroke (Version -R) ① = Blade opening adjustment ② = Locking ③ = Max. blade opening ④ = Connection air nipper  
 ⑤ = Connection stroke movement ⑥ = Stroke adjustment

Item no.	A [mm]	B [mm]	C [mm]	D [mm]	E [mm]	F [mm]	G [mm]	H	I [mm]
GT-NT03	62	19	68.1	9	7	43	14	M3	3
GT-NT03R	62	19	68.1	9	7	43	14	M3	3
GT-NT03-4	62	19	68.1	9	7	43	14	M3	3
GT-NT03R-4	62	19	68.1	9	7	43	14	M3	3
GT-NT05	64	32	71.1	9	7	45	20	M4	6
GT-NT05R	64	32	71.1	9	7	45	20	M4	6
GT-NT05-4	64	32	71.1	9	7	45	20	M4	6
GT-NT05R-4	64	32	71.1	9	7	45	20	M4	6
GT-NT10	73	38	88.1	11	8	52	24	M4	7
GT-NT10R	73	38	88.1	11	8	52	24	M4	7
GT-NT10-6	73	38	88.1	11	8	52	24	M4	7
GT-NT10R-6	73	38	88.1	11	8	52	24	M4	7
GT-NT20	103	44	102.1	14	10	80	28	M5	9
GT-NT20R	103	44	102.1	14	10	80	28	M5	9
GT-NT20-6	103	44	102.1	14	10	80	28	M5	9
GT-NT20R-6	103	44	102.1	14	10	80	28	M5	9



### Blades for plastic, stationary, straight



#### Product notes

- > Straight blades that can be applied at the right angle to the gate
- > Models with a variety of cutting edges to cover different applications
- > AJ: standard blade
- > RAJ: reverse cutting edge if cutting flush to workpiece with blade "AJ" is not possible
- > AJT: blade extra thin
- > AJL: blade extra long to overcome distance between sprue and nipper
- > AJB:
  - Soldered carbide tips for cutting hard plastics or plastics containing fiberglass
  - Higher lifetime in demanding applications

#### Technical data

Item no.	Material	Max. cutting thickness [mm]		Design	Weight [g]	Air nippers
		PP/PE	ABS			
<b>NY05AJ</b>	Ferrous alloy	3	2	Standard blade	22	GT-NF05, GT-NY05, GT-NY05-4
<b>NY05AJB</b>	Ferrous alloy	3	2	soldered carbide tips	22	GT-NF05, GT-NY05, GT-NY05-4
<b>NY05AJL</b>	Ferrous alloy	3	2	Blade extra long	29	GT-NF05, GT-NY05, GT-NY05-4
<b>NY05AJT</b>	Ferrous alloy	3	2	Blade extra thin	21	GT-NF05, GT-NY05, GT-NY05-4
<b>NY05RAJ</b>	Ferrous alloy	3	2	reverse cutting edge	22	GT-NF05, GT-NY05-4, GT-NY05R, GT-NY05R-4
<b>NY10AJ</b>	Ferrous alloy	3.5	2.3	Standard blade	28	GT-NF10, GT-NY10, GT-NY10-4
<b>NY10AJB</b>	Sintered alloy	3.5	2.3	soldered carbide tips	28	GT-NF10, GT-NY10-4, GT-NY10R
<b>NY10AJL</b>	Ferrous alloy	3.5	2.3	Blade extra long	37	GT-NF10, GT-NY10, GT-NY10-4
<b>NY10AJT</b>	Ferrous alloy	3.5	2.3	Blade extra thin	26	GT-NF10, GT-NY10, GT-NY10-4
<b>NY10RAJ</b>	Ferrous alloy	3.5	2.3	reverse cutting edge	28	GT-NF10, GT-NY10R, GT-NY10R-4
<b>NY15AJ</b>	Ferrous alloy	4	2.6	Standard blade	41	GT-NF15, GT-NY15, GT-NY15-4
<b>NY15AJB</b>	Sintered alloy	4	2.6	soldered carbide tips	41	GT-NF15, GT-NY15-4, GT-NY15R
<b>NY15AJL</b>	Ferrous alloy	4	2.6	Blade extra long	50	GT-NF15, GT-NY15, GT-NY15-4
<b>NY15RAJ</b>	Ferrous alloy	4	2.6	reverse cutting edge	41	GT-NF15, GT-NY15R, GT-NY15R-4
<b>NY15AJT</b>	Ferrous alloy	4	2.6	Blade extra thin	38	GT-NF15, GT-NY15, GT-NY15R-4
<b>NY25AJ</b>	Ferrous alloy	5	3.4	Standard blade	77	GT-NY25, GT-NY25-6
<b>NY25RAJ</b>	Ferrous alloy	5	3.4	reverse cutting edge	77	GT-NY25, GT-NY25R-6
<b>NY25AJB</b>	Sintered alloy	5	3.4	soldered carbide tips	77	GT-NY25, GT-NY25R-6
<b>NY25AJL</b>	Ferrous alloy	5	3.4	Blade extra long	88	GT-NY25, GT-NY25-6



## Dimensions

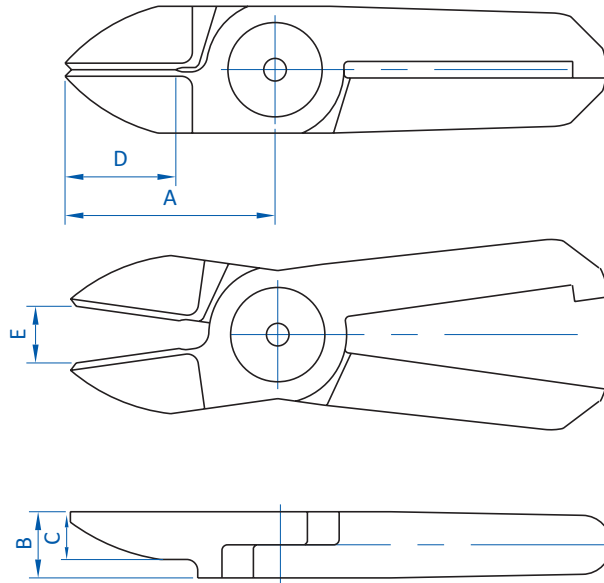

Item no.	A [mm]	B [mm]	C [mm]	D [mm]	E [mm]
NY05AJ	22	7	5	10.5	4
NY05AJB	22	7	5	10.5	4
NY05AJL	31	7	5	10.5	5.5
NY05AJT	22	7	3	10.5	4
NY05RAJ	22	7	5	10.5	4
NY10AJ	24	7.2	5	12	6
NY10AJB	24	7.2	5	12	6
NY10AJL	33	7.2	5	12	8
NY10AJT	24	7.2	3	12	6
NY10RAJ	24	7.2	5	12	6
NY15AJ	27	8.2	5.5	13	8
NY15AJB	27	8.2	5.5	13	8
NY15AJL	38	8.2	5.5	13	11
NY15RAJ	27	8.2	5.5	13	8
NY15AJT	27	8.2	3.5	13	8
NY25AJ	31	10	6	16	9
NY25RAJ	31	10	6	16	9
NY25AJB	31	10	6	16	9
NY25AJL	46	10	6	16	13



### Blades for plastic, stationary, Z-shape



#### Product notes

- > Blades with offset cutting edge for overcoming obstacles or for narrow sprues
- > AH: standard blade
- > RAH: reverse cutting edge if cutting flush to workpiece with blade "AH" is not possible

#### Technical data

Item no.	Material	Max. cutting thickness [mm]		Design	Weight [g]	Air nippers
		PP/PE	ABS			
<b>NY05AH</b>	Ferrous alloy	3	2	Standard blade	37	GT-NF05 GT-NY05-4 GT-NY05
<b>NY05RAH</b>	Ferrous alloy	3	2	reverse cutting edge	31	GT-NF05 GT-NY05R-4 GT-NY05R
<b>NY10AH</b>	Ferrous alloy	3.5	2.3	Standard blade	43	GT-NF10 GT-NY10-4 GT-NY10
<b>NY10RAH</b>	Ferrous alloy	3.5	2.3	reverse cutting edge	40	GT-NF10 GT-NY10R GT-NY10R-4
<b>NY15AH</b>	Ferrous alloy	4	2.6	Standard blade	76	GT-NF15 GT-NY15-4 GT-NY15
<b>NY15RAH</b>	Ferrous alloy	4	2.6	reverse cutting edge	52	GT-NF15 GT-NY15R-4 GT-NY15R
<b>NY25AH</b>	Ferrous alloy	5	3.4	Standard blade	110	GT-NY25 GT-NY25-6
<b>NY25RAH</b>	Ferrous alloy	5	3.4	reverse cutting edge	89	GT-NY25 GT-NY25R GT-NY25R-6





## Dimensions

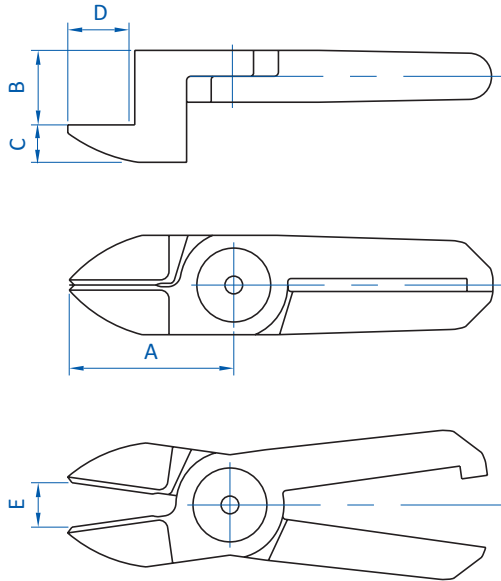

NY05AH | NY10AH | NY15AH | NY25AH

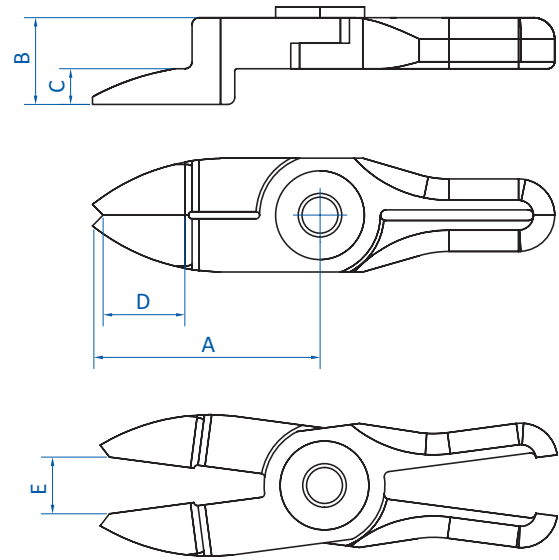

NY05RAH | NY10RAH | NY15RAH | NY25RAH

Item no.	A [mm]	B [mm]	C [mm]	D [mm]	E [mm]
NY05AH	31	14	5	13	5.5
NY05RAH	30	7	5	12	5
NY10AH	33	15	5	15	8
NY10RAH	32	7	5	15	7
NY15AH	38	16	5.5	16	11
NY15RAH	35	7.7	5.5	15	9
NY25AH	46	18	6	19	13
NY25RAH	42	16	5	18	12



# Nipper technology | Blades – stationary

Blades for metal wire, stationary, straight

## Blades for metal wire, stationary, straight



### Product notes

- > Straight blades that can be applied at the right angle to the gate
- > Blades for cutting metal, unbeveled cutting edge using the anvil principle
- > BJ: standard blade
- > RBJ: reverse cutting edge if cutting flush to workpiece with blade "BJ" is not possible

### Technical data

Item no.	Material	Max. cutting thickness [mm]		Design	Weight [g]	Air nippers
		Copper wire	Steel wire			
NY05BJ	Ferrous alloy	1.6	1	straight	22	GT-NF05 GT-NY05-4 GT-NY05
NY05RBJ	Ferrous alloy	1.6	1	straight	22	GT-NF05 GT-NY05R GT-NY05R-4

### Dimensions

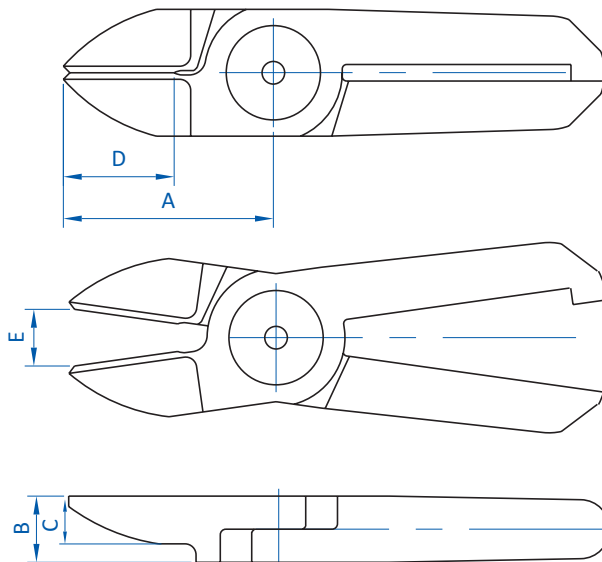

Item no.	A [mm]	B [mm]	C [mm]	D [mm]	E [mm]
NY05BJ	22	7	5	9	3.5
NY05RBJ	22	7	5	10.5	4



### Blades for plastic, for vertical air nippers, straight



#### Product notes

- > Straight blades that can be applied at the right angle to the gate
- > Models with a variety of cutting edges to cover different applications
- > AJ: standard blade
- > AJT: blade extra thin
- > AJL: blade extra long to overcome distance between sprue and nipper
- > AJB: brazed carbide tips for cutting hard plastics or plastics containing fiberglass, increased durability
- > AJH: brazed high-speed steel tip for cutting hard plastic

#### Technical data

Item no.	Material	Max. cutting thickness [mm]		Design	Weight [g]	Air nippers
		PP/PE	ABS			
<b>NT03AJ</b>	Ferrous alloy	1.5	1	Standard blade	20	GT-NT03
<b>NT03AJT</b>	Ferrous alloy	1.5	1	Blade extra thin	19	GT-NT03
<b>NE05AJ</b>	Ferrous alloy	2.5	1.5	Standard blade	35	GT-NT05
<b>NT05AJ</b>	Ferrous alloy	2.5	1.5	Standard blade long	30	GT-NT05
<b>NT05AJB</b>	Sintered alloy	2.5	1.5	brazed carbide tips	30	GT-NT05
<b>NT05AJH</b>	HSS steel	2.5	1.5	brazed tips	30	GT-NT05
<b>NT05AJL</b>	Ferrous alloy	2.5	1.5	Blade extra long	39	GT-NT05
<b>NT05AJT</b>	Ferrous alloy	2.5	1.5	Blade extra thin	29	GT-NT05
<b>NE10AJ</b>	Ferrous alloy	3.5	2.3	Standard blade	70	GT-NT10
<b>NT10AJ</b>	Ferrous alloy	3.5	2.3	Standard blade long	62	GT-NT10
<b>NT10AJB</b>	Sintered alloy	3.5	2.3	brazed carbide tips	76	GT-NT10
<b>NT10AJH</b>	HSS steel	3.5	2.3	brazed tips	76	GT-NT10
<b>NT10AJL</b>	Ferrous alloy	3.5	2.3	Blade extra long	62	GT-NT10
<b>NT10AJT</b>	Ferrous alloy	3.5	2.3	Blade extra thin	65	GT-NT10
<b>NT20AJ</b>	Ferrous alloy	5	3.4	Standard blade	120	GT-NT20
<b>NT20AJB</b>	Ferrous alloy	5	3.4	brazed carbide tips	120	GT-NT20
<b>NT20AJH</b>	HSS steel	5	3.4	brazed tips	120	GT-NT20
<b>NT20AJL</b>	Ferrous alloy	5	3.4	Blade extra long	114	GT-NT20

Continued on the next page →



# Nipper technology | Blades – stationary

Blades for plastic, for vertical air nippers, straight

## Dimensions

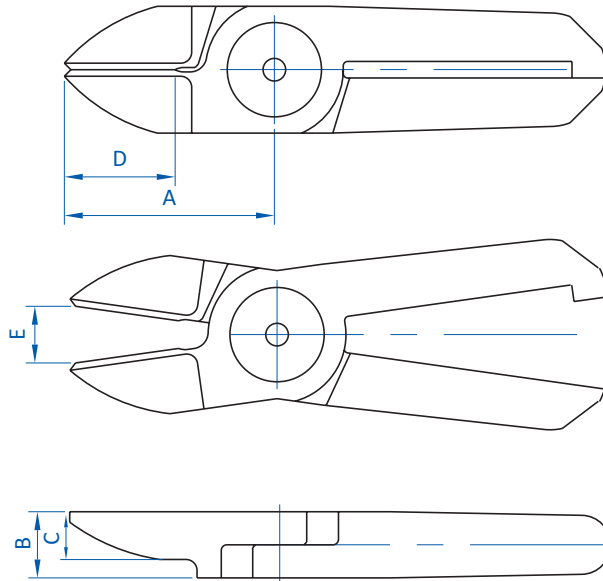

Item no.	A [mm]	B [mm]	C [mm]	D [mm]	E [mm]
NT03AJ	24	7	4	11	3
NT03AJT	24	7	2.3	11	3
NE05AJ	24	7	3.5	12	6
NT05AJ	29	7	5	15	6
NT05AJB	29	7	5	15	6
NT05AJH	29	7	5	15	6
NT05AJL	36	7	5	15	7
NT05AJT	29	7	3	15	6
NE10AJ	27	9	4.5	12	7
NT10AJ	35	9	6	17	7
NT10AJB	35	9	6	17	7
NT10AJH	35	9	6	17	7
NT10AJL	47	9	6	17	9
NT10AJT	35	9	4	17	7
NT20AJ	40	12	6	20	9
NT20AJB	40	12	6	20	9
NT20AJH	40	12	6	20	9
NT20AJL	57	12	6	20	12



## Blades for plastic, for vertical air nippers, nipper style



### Product notes

> Blades, nipper style, for universal cutting applications

### Technical data

Item no.	Material	Max. cutting thickness [mm]		Design	Weight [g]	Air nippers
		PP/PE	ABS			
NT05AE	Ferrous alloy	2.5	1.5	nipper style	36	GT-NT05
NT10AE	Ferrous alloy	3.5	2.3	nipper style	75	GT-NT10

### Dimensions

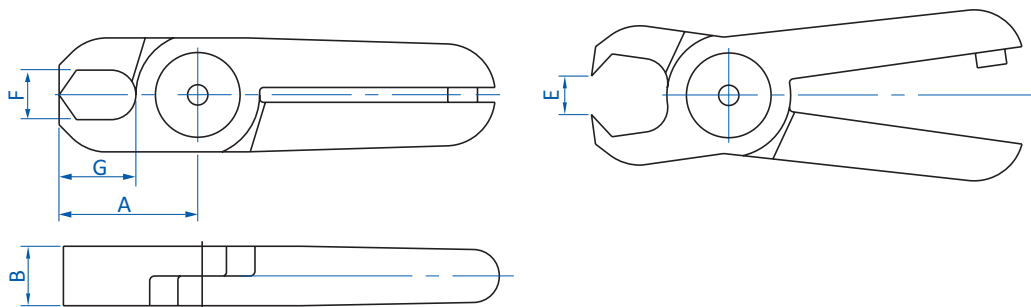

Item no.	A [mm]	B [mm]	E [mm]	F [mm]	G [mm]
NT05AE	29	7	6	6	18
NT10AE	35	9	7	8	21.5



# Nipper technology | Air shears

Special air shears – round/square, single-acting

## Special air shears – round/square, single-acting



### Product notes

- > Pneumatic
- > for robots, cutting stations or manual operations shears For precision cutting of kevlar, aramid, glass and carbon fiber
- > GT-H30, GT-HS30, GT-H12K: designed to cut synthetic materials; not suitable for thick cardboard, tin plate, wire, wood, etc.
- > Blades are not included in the scope of delivery. Please order separately.

### Technical data

Item no.	Housing	Air consumption [cm <sup>3</sup> /stroke]	Operating pressure [bar (psi)]	Functional principle	Length incl. blade [mm]	Connection [G]	Max. cutting thickness [mm]		Weight [g]
							Band steel	Kevlar	
GT-H12K	Round	116	2 (29)	Manually	186	R1/8	--	0.3	290
GT-H120K	Round	116	5 - 6 (72.5 - 87)	Manually	211	R1/8	15x0.5	--	340
GT-H30	Round	584	3 (43.5)	Manually	280	R1/8	--	1	1,030
GT-HS30	Square	584	3 (43.5)	Automatically	260	R1/8	--	1	970

### Dimensions

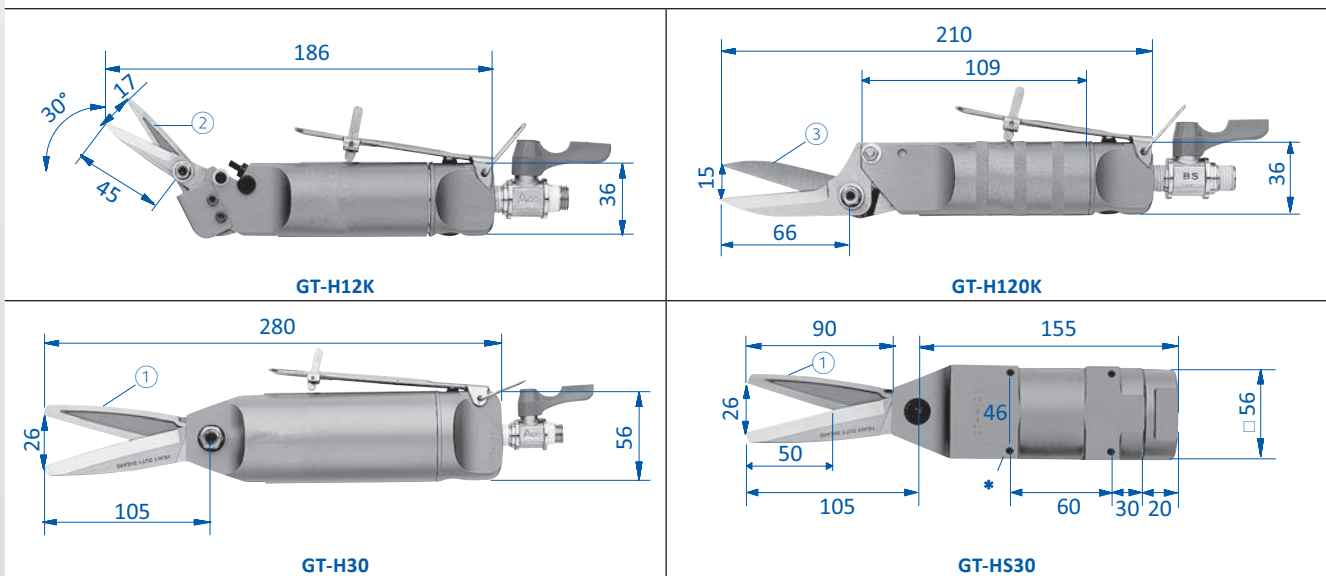

① = Blade shown: H30ME ② = Blade shown: H12ME30K ③ = Blade shown: H120SK \* = 4 x 4 bore holes M5



## Blades for special air shears, single-acting



### Product notes

- > Blades for cutting synthetic materials, e.g. kevlar, aramid, glass and carbon fiber
- > With the exception of H120SK not suitable for thick cardboard, sheet tin, wire, wood

### Technical data

Item no.	Max. opening for cutting [mm]	Effective cutting length [mm]	Max. cutting thickness [mm]		Weight [g]	Air nippers
			Kevlar	Band steel		
H30ME	26	50	1	--	280	GT-H30 GT-HS30
H12ME30K	17	28	0.3	--	56	GT-H12K
H120SK	15	38	--	15x0.5	115	GT-H120K

### Dimensions

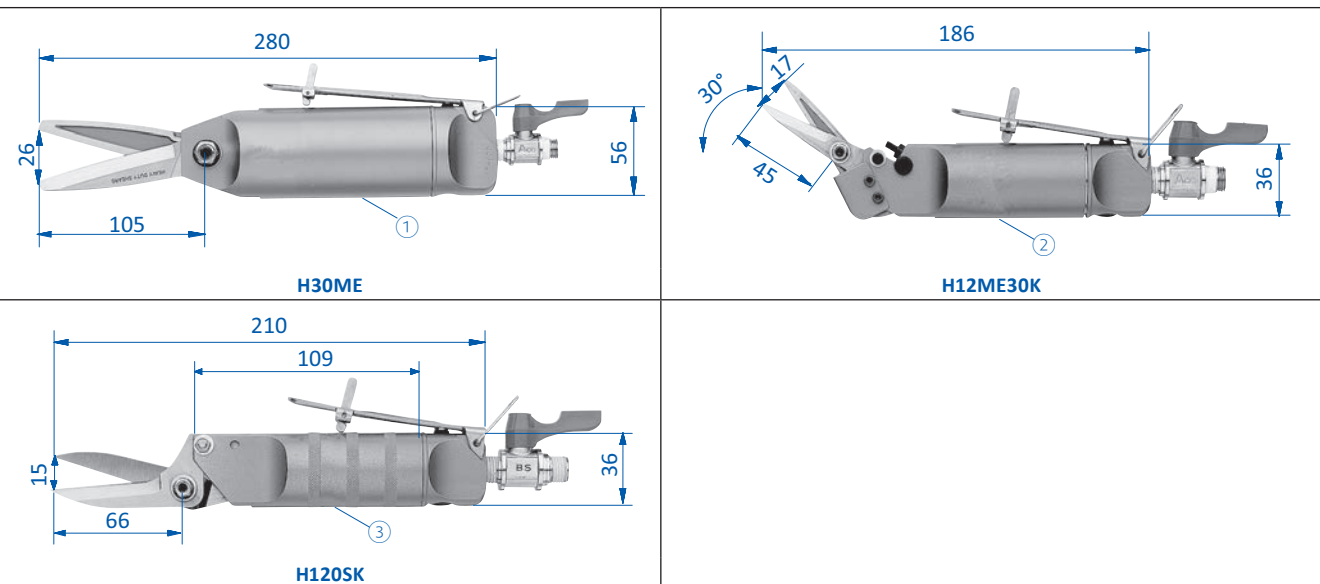

① = Special air shear shown: GT-H30    ② = Special air shear shown: GT-H12K    ③ = Special air shear shown: GT-H120K



### Air shears – round/square, double-acting



FOR FAST CYCLE TIMES

#### Product notes

- > Pneumatic shears for robots, cutting stations or manual operation
- > Cutting of paper, film, steel or copper wire, etc.
- > Double-acting, separate control of opening and closing to enable short duty cycles
- > Continuous cutting process as no return spring required
- > Blades are not included in the scope of delivery. Please order separately.

#### Technical data

Item no.	Housing	Max. cutting force [N]	Air consumption [cm <sup>3</sup> /stroke]	Operating pressure [bar (psi)]	Pipe connection [mm]	Weight [g]
GT-HWS1	Square	294	45	4 - 5 (58 - 72.5)	4	116
GT-HWR1	Round	294	45	4 - 5 (58 - 72.5)	4	84
GT-HWS10	Square	588	116	4 - 5 (58 - 72.5)	6	356
GT-HWR10	Round	588	116	4 - 5 (58 - 72.5)	6	295

#### Dimensions

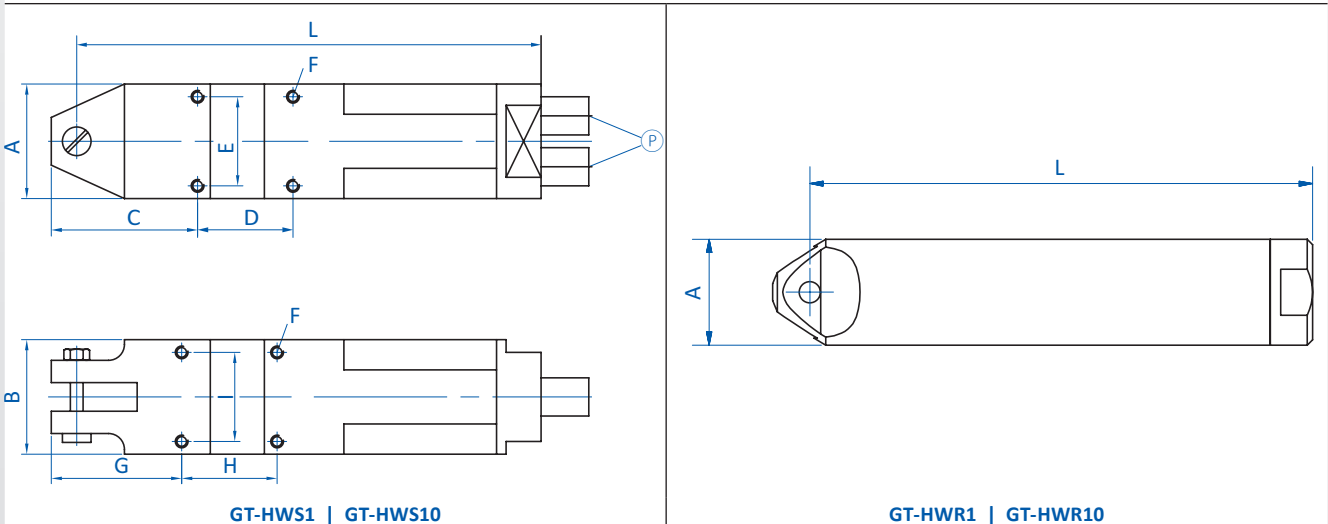

Ⓟ = Compressed air connection

Item no.	A [mm]	B [mm]	C [mm]	D [mm]	E [mm]	F	G [mm]	H [mm]	I [mm]	L [mm]
GT-HWS1	20	23	--	--	--	M3	24	40	16	95
GT-HWR1	20	--	--	--	--	--	--	--	--	95
GT-HWS10	36	36	45.5	30	28	M4	41	30	28	146
GT-HWR10	36	--	--	--	--	--	--	--	--	146





## Blades for double-acting air shears



### Product notes

- > Blades for double-acting air shears
- > Suitable for cutting copper or steel wire

### Technical data

Item no.	Max. opening for cutting [mm]	Effective cutting length [mm]	Max. cutting thickness [mm]		Weight [g]	Air nippers
			Copper wire	Steel wire		
HW1J	3	17	1	0.5	116	GT-HWR1 GT-HWS1
HW10J	5	28	1.8	1.2	84	GT-HWR10 GT-HWS10

### Dimensions

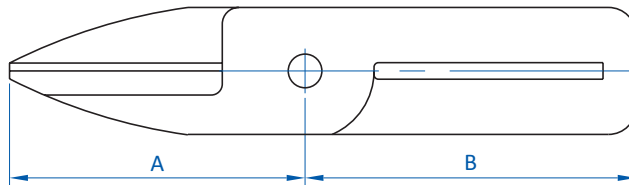

Item no.	A [mm]	B [mm]
HW1J	25	30
HW10J	40	55



### Air-nipper mounting brackets



#### Product notes

> Mounting brackets to fasten air nippers to angle clamps

#### Technical data

Item no.	Clamping $\varnothing$ [mm]	Weight [g]	Air nippers
GT-NR10H	14	38	GT-NR10L
GT-NR20H	20	71	GT-NR20
GT-NR30H	20	79	GT-NR30
GT-NR50H	20	149	GT-NR50

#### Dimensions

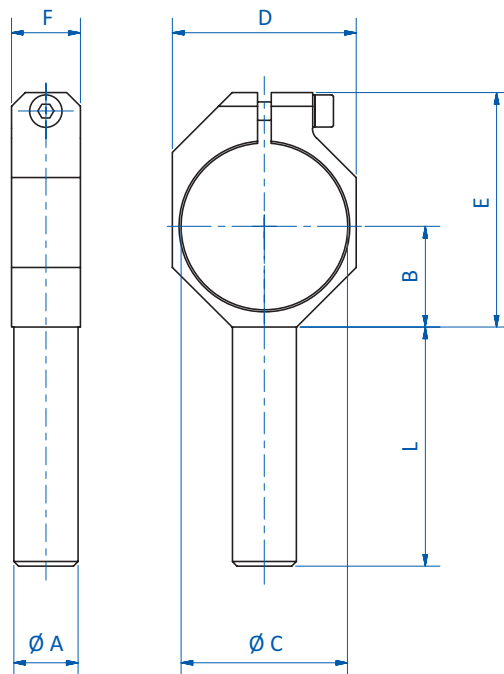

Item no.	$\varnothing A$ [mm]	B [mm]	$\varnothing C$ [mm]	D [mm]	E [mm]	F [mm]	L [mm]
GT-NR10H	14	22	36	40	51	15	52
GT-NR20H	20	30	45	50	65	20	52
GT-NR30H	20	35	56	60	75	20	52
GT-NR50H	20	45	75	85	95	20	52



### Mounting clamps for air nippers



Air nipper GT-NR20 with mounting clamp

#### Product notes

- > Space-saving assembly of air nippers on extrusions and special machines
- > The clamps are part of air nipper fittings GT-NR10ST2 to GT-NR30ST2

#### Technical data

Item no.	Weight [g]	Air nippers
GT-NR10S	36	GT-NR10L
GT-NR20S	39	GT-NR20
GT-NR30S	46	GT-NR30
GT-NR50S	58	GT-NR50

#### Dimensions

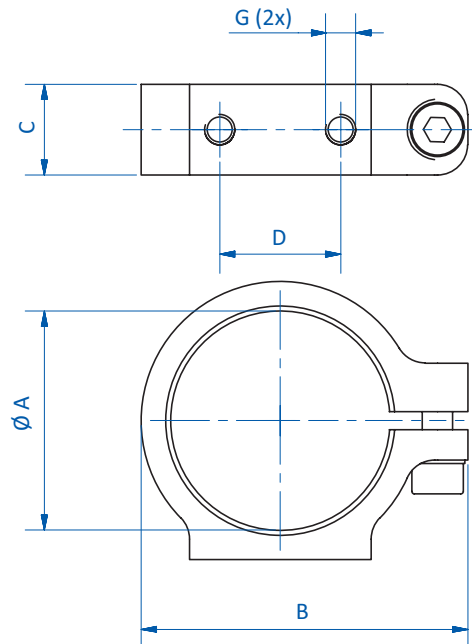

Item no.	Ø A [mm]	B [mm]	C [mm]	D [mm]	G
GT-NR10S	36	54	15	20	M5
GT-NR20S	45	62.5	15	20	M5
GT-NR30S	56	73.5	15	20	M5
GT-NR50S	75	92.5	15	20	M5



### Clamps with angle brackets – for direct mounting

Mounting air nippers on EOAT or special machines

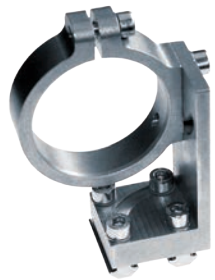

Air nipper GT-NR20 assembled on extrusion SLine

#### Product notes

- > Mounting bracket for installation on grippers or special machines
- > Easy positioning of the air nipper thanks to 2x 90° adjustable design
- > Versatile thanks to alternative installation using slot nuts or threaded shaft holder
- > Slot nuts and mounting screws for installation on FIPA SLine and MLine extrusions included in scope of delivery

#### Technical data

Item no.	Weight [g]	Air nippers
GT-NR10ST2	116	GT-NR10L
GT-NR20ST2	119	GT-NR20
GT-NR30ST2	125	GT-NR30
GT-NR50ST2	165	GT-NR50

#### Dimensions

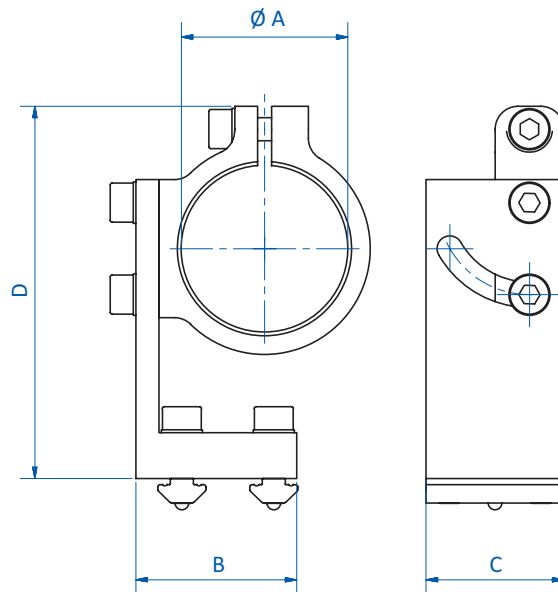

Item no.	Ø A [mm]	B [mm]	C [mm]	D [mm]
GT-NR10ST2	36	35	30	81
GT-NR20ST2	45	35	30	87.5
GT-NR30ST2	56	35	30	90.5
GT-NR50ST2	75	35	30	109.5



Gripper clamps



Product notes

- > Mounting of the grippers to the air nippers for holding the sprue during the cutting process
- > Optimal adjustment by using elbow gripper arms

Technical data

Item no.	Weight [g]	Air nippers
GT-NR10GR	57	GT-NR10L
GT-NR20GR	60	GT-NR20
GT-NR30GR	66	GT-NR30
GT-NR50GR	82	GT-NR50

Dimensions

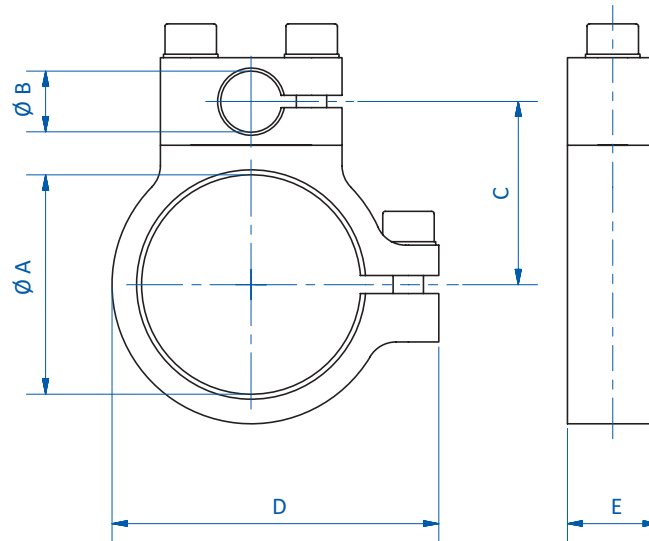

Item no.	Ø A [mm]	Ø B [mm]	C [mm]	D [mm]	E [mm]
GT-NR10GR	36	10	30.25	54	15
GT-NR20GR	45	10	34.75	62.5	15
GT-NR30GR	56	10	40.25	73.5	15
GT-NR50GR	75	10	53	92.5	15



### Pressure booster for air nippers GT-N, GT-NR, GT-NS



Air nippers GT-NS20 with pressure booster

#### Product notes

- > Pressure booster for retrofitting
- > Increase in cutting force if the required cutting force cannot be achieved with a standard nipper

#### Technical data

Item no.	Total cutting force [N]	Air consumption [cm <sup>3</sup> /stroke]	Construction size	Weight [g]	Air nippers
<b>P-10L</b>	980	223	10L	110	GT-NR10L GT-NS10L GT-N12
<b>P-20</b>	2,254	508	20	208	GT-N20 GT-NR20 GT-NS20
<b>P-30</b>	4,410	956	30	315	GT-N30 GT-NR30 GT-NS30
<b>P-50</b>	7,742	2,670	50	776	GT-N50 GT-NR50

#### Dimensions

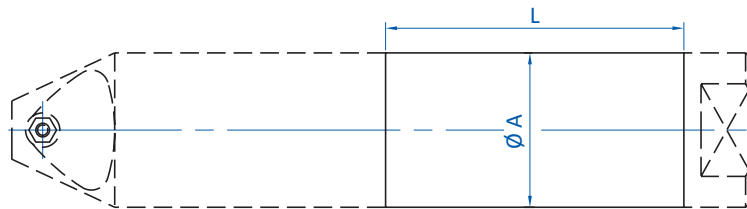

Item no.	Ø A [mm]	L [mm]
<b>P-10L</b>	36	71
<b>P-20</b>	45	87
<b>P-30</b>	56	92
<b>P-50</b>	75	133

Lifting cylinders .....	310
Short lifting cylinders .....	312
Dual-piston cylinders .....	317
Guide blocks .....	319
Rotary units .....	329
Accessories .....	334

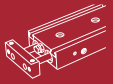

### Lifting cylinders – vacuum-operated

Torsionally rigid



55.000 | 55.001 | 55.004



55.002

#### Product notes

- > Picking-up and stacking flat and sensitive objects such as e.g. signs, cards, paper, veneers
- > Suitable for short cycle times
- > Robust aluminum housing, Hartcoat® treated
- > Non-rotating piston rod
- > Low-noise version
- > 55.002: stacking and lifting of metal sheet and heavy parts
- > Not suitable for workpieces permeable to air
- > Customized sizes on request

#### Technical data

Item no.	Stroke [mm]	Volume flow at 80 % vacuum [Nl/min]	Lifting force at 80 % vacuum [N]	Cycle time (extend-suction-lift) [s]	Operating temperature [°C (°F)]	Weight [g]
55.000	17	15	3	0.3	5 - 80 (41 - 176)	39
55.001	25	35	7	0.4	5 - 80 (41 - 176)	111
55.002	30	35	50	1.4	5 - 80 (41 - 176)	331
55.004	40	35	7	0.8	5 - 80 (41 - 176)	138

#### Dimensions

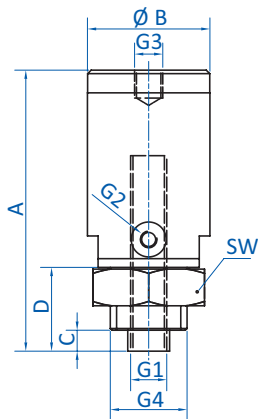

55.000 | 55.001 | 55.004

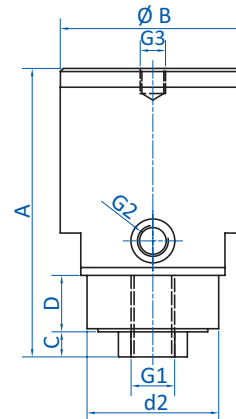

55.002

Item no.	G1	G2	G3	G4	A [mm]	Ø B [mm]	C [mm]	D [mm]	d2 [mm]	SW
55.000	M5	M5	M6	M16x1.5	55.5	24	4	16	--	19
55.001	G1/8	M5	M8	M22x1.5	78	35	6	22	--	27
55.002	G1/4	G1/4	M10	--	92	59	8	18	42	--
55.004	G1/8	G1/8	M8	M22x1.5	99	35	9	24	--	27



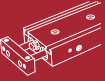

Diagrams

> Double stroke lifting time against weight

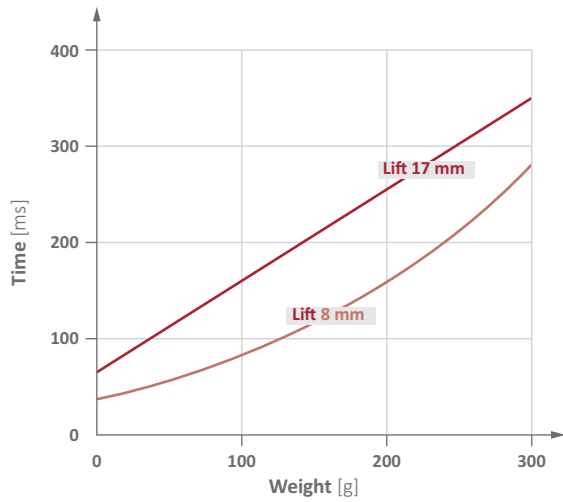

55.000

> Double stroke lifting time against weight

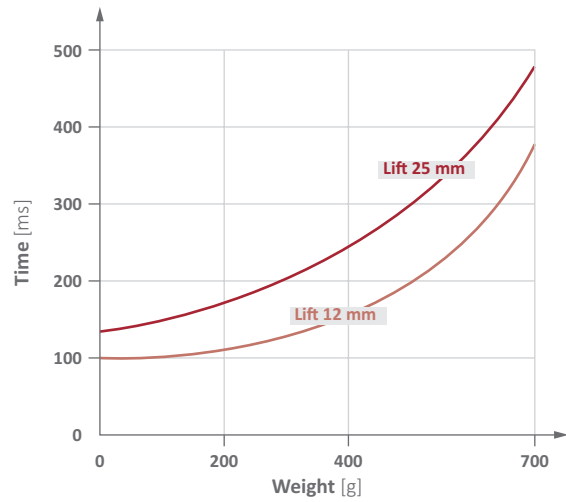

55.001

> Double stroke lifting time against weight

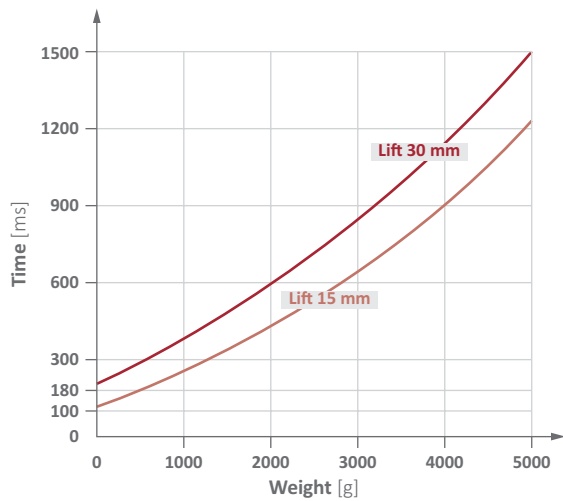

55.002

> Double stroke lifting time against weight

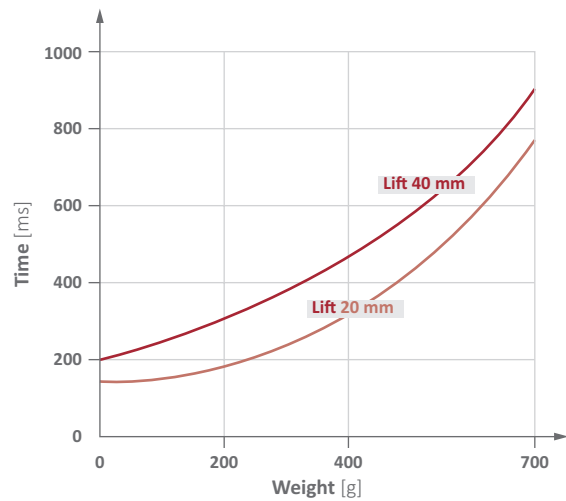

55.004

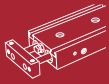

### Short stroke cylinders – double-acting

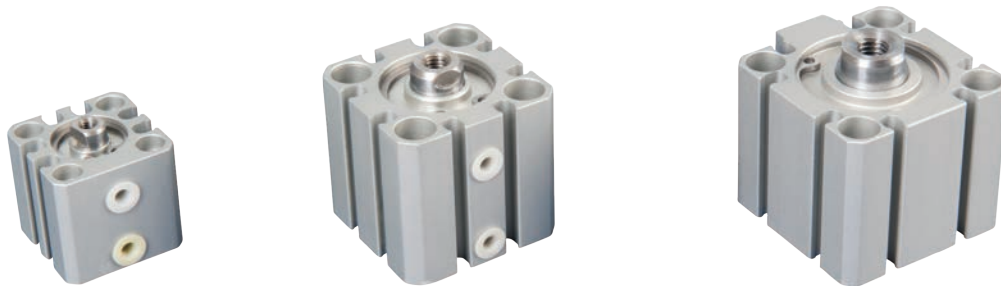

#### Product notes

- > Elements to guide gripper components such as vacuum cups to the workpiece
- > Double-acting, separate compressed air connections for extraction and retraction
- > Medium: filtered and oiled/unoiled air
- > Operating pressure: 0.5 - 9.9 bar (7.3 - 143.6 psi)
- > Operating temperature: -5 - 60 °C (23 - 140 °F)
- > Sensors for optional detection of piston position (extracted/retracted)
- > Through mounting option with mounting screw kits (please order separately according to cylinder size, consists of 4 screws/washers)
- > Further stroke versions available on request
- > PNP and NPN sensors:
  - C-slot (90° angle): GR04.202P, GR04.202N
  - C-slot (straight, short design): GR04.280P, GR04.280N
- > Can be used as gripper tool when combined with pressure plates GR07.196 - GR07.199

#### Technical data

Item no.	Compressed air connection	Piston diameter [mm]	Stroke [mm]	Weight [g]	Accessories
<b>GR07.012-5</b>	M5	12	5	35	Mounting bracket: GR06.100, Mounting bracket: GR07.060, Mounting bracket: GR06.080, Sensor: GR04.202N, Sensor: GR04.202P, Sensor: GR04.280N, Sensor: GR04.280P, Kit of mounting screws: GR07.012-5-KIT
<b>GR07.012-10</b>	M5	12	10	42	Mounting bracket: GR06.100, Mounting bracket: GR07.060, Mounting bracket: GR06.080, Sensor: GR04.202N, Sensor: GR04.202P, Sensor: GR04.280N, Sensor: GR04.280P, Kit of mounting screws: GR07.012-10-KIT
<b>GR07.016-5</b>	M5	16	5	45	Mounting bracket: GR06.081, Sensor: GR04.202N, Sensor: GR04.202P, Sensor: GR04.280N, Sensor: GR04.280P, Kit of mounting screws: GR07.016-5-KIT
<b>GR07.016-10</b>	M5	16	10	53	Mounting bracket: GR06.081, Sensor: GR04.202N, Sensor: GR04.202P, Sensor: GR04.280N, Sensor: GR04.280P, Kit of mounting screws: GR07.016-10-KIT
<b>GR07.016-20</b>	M5	16	20	69	Mounting bracket: GR06.081, Sensor: GR04.202N, Sensor: GR04.202P, Sensor: GR04.280N, Sensor: GR04.280P, Kit of mounting screws: GR07.016-20-KIT
<b>GR07.016-30</b>	M5	16	30	85	Mounting bracket: GR06.081, Sensor: GR04.202N, Sensor: GR04.202P, Sensor: GR04.280N, Sensor: GR04.280P, Kit of mounting screws: GR07.016-30-KIT
<b>GR07.020-5</b>	M5	20	5	88	Mounting bracket: GR06.109, Mounting bracket: GR07.061, Mounting bracket: GR06.082, Sensor: GR04.202N, Sensor: GR04.202P, Sensor: GR04.280N, Sensor: GR04.280P, Kit of mounting screws: GR07.020-5-KIT
<b>GR07.020-10</b>	M5	20	10	101	Mounting bracket: GR06.109, Mounting bracket: GR07.061, Mounting bracket: GR06.082, Sensor: GR04.202N, Sensor: GR04.202P, Sensor: GR04.280N, Sensor: GR04.280P, Kit of mounting screws: GR07.020-10-KIT
<b>GR07.020-20</b>	M5	20	20	127	Mounting bracket: GR06.109, Mounting bracket: GR07.061, Mounting bracket: GR06.082, Sensor: GR04.202N, Sensor: GR04.202P, Sensor: GR04.280N, Sensor: GR04.280P, Kit of mounting screws: GR07.020-20-KIT
<b>GR07.020-30</b>	M5	20	30	153	Mounting bracket: GR06.109, Mounting bracket: GR07.061, Mounting bracket: GR06.082, Sensor: GR04.202N, Sensor: GR04.202P, Sensor: GR04.280N, Sensor: GR04.280P, Kit of mounting screws: GR07.020-30-KIT

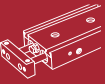

### Technical data

Item no.	Compressed air connection	Piston diameter [mm]	Stroke [mm]	Weight [g]	Accessories
<b>GR07.020-50</b>	M5	20	50	205	Mounting bracket: GR06.109, Mounting bracket: GR07.061, Mounting bracket: GR06.082, Sensor: GR04.202N, Sensor: GR04.202P, Sensor: GR04.280N, Sensor: GR04.280P, Kit of mounting screws: GR07.020-50-KIT
<b>GR07.025-5</b>	M5	25	5	139	Mounting bracket: GR06.083, Sensor: GR04.202N, Sensor: GR04.202P, Sensor: GR04.280N, Sensor: GR04.280P, Stroke limiters: GR04.229-KIT, Kit of mounting screws: GR07.025-5-KIT
<b>GR07.025-10</b>	M5	25	10	155	Mounting bracket: GR06.083, Sensor: GR04.202N, Sensor: GR04.202P, Sensor: GR04.280N, Sensor: GR04.280P, Stroke limiters: GR04.229-KIT, Kit of mounting screws: GR07.025-10-KIT
<b>GR07.025-20</b>	M5	25	20	187	Mounting bracket: GR06.083, Sensor: GR04.202N, Sensor: GR04.202P, Sensor: GR04.280N, Sensor: GR04.280P, Stroke limiters: GR04.229-KIT, Kit of mounting screws: GR07.025-20-KIT
<b>GR07.025-30</b>	M5	25	30	219	Mounting bracket: GR06.083, Sensor: GR04.202N, Sensor: GR04.202P, Sensor: GR04.280N, Sensor: GR04.280P, Stroke limiters: GR04.229-KIT, Kit of mounting screws: GR07.025-30-KIT
<b>GR07.025-50</b>	M5	25	50	283	Mounting bracket: GR06.083, Sensor: GR04.202N, Sensor: GR04.202P, Sensor: GR04.280N, Sensor: GR04.280P, Stroke limiters: GR04.229-KIT, Kit of mounting screws: GR07.025-50-KIT
<b>GR07.032-5</b>	G1/8	32	5	192	Mounting bracket: GR06.115, Mounting bracket: GR07.062, Mounting bracket: GR06.084, Mounting bracket: GR06.085, Sensor: GR04.202N, Sensor: GR04.202P, Sensor: GR04.280N, Sensor: GR04.280P, Stroke limiters: GR04.330-KIT, Kit of mounting screws: GR07.032-5-KIT
<b>GR07.032-10</b>	G1/8	32	10	214	Mounting bracket: GR06.115, Mounting bracket: GR07.062, Mounting bracket: GR06.084, Mounting bracket: GR06.085, Sensor: GR04.202N, Sensor: GR04.202P, Sensor: GR04.280N, Sensor: GR04.280P, Stroke limiters: GR04.330-KIT, Kit of mounting screws: GR07.032-10-KIT
<b>GR07.032-15</b>	G1/8	32	15	236	Mounting bracket: GR06.115, Mounting bracket: GR07.062, Mounting bracket: GR06.084, Mounting bracket: GR06.085, Sensor: GR04.202N, Sensor: GR04.202P, Sensor: GR04.280N, Sensor: GR04.280P, Stroke limiters: GR04.330-KIT, Kit of mounting screws: GR07.032-15-KIT
<b>GR07.032-20</b>	G1/8	32	20	258	Mounting bracket: GR06.115, Mounting bracket: GR07.062, Mounting bracket: GR06.084, Mounting bracket: GR06.085, Sensor: GR04.202N, Sensor: GR04.202P, Sensor: GR04.280N, Sensor: GR04.280P, Stroke limiters: GR04.330-KIT, Kit of mounting screws: GR07.032-20-KIT
<b>GR07.032-25</b>	G1/8	32	25	280	Mounting bracket: GR06.115, Mounting bracket: GR07.062, Mounting bracket: GR06.084, Mounting bracket: GR06.085, Sensor: GR04.202N, Sensor: GR04.202P, Sensor: GR04.280N, Sensor: GR04.280P, Stroke limiters: GR04.330-KIT, Kit of mounting screws: GR07.032-25-KIT
<b>GR07.032-30</b>	G1/8	32	30	302	Mounting bracket: GR06.115, Mounting bracket: GR07.062, Mounting bracket: GR06.084, Mounting bracket: GR06.085, Sensor: GR04.202N, Sensor: GR04.202P, Sensor: GR04.280N, Sensor: GR04.280P, Stroke limiters: GR04.330-KIT, Kit of mounting screws: GR07.032-30-KIT
<b>GR07.032-35</b>	G1/8	32	35	324	Mounting bracket: GR06.115, Mounting bracket: GR07.062, Mounting bracket: GR06.084, Mounting bracket: GR06.085, Sensor: GR04.202N, Sensor: GR04.202P, Sensor: GR04.280N, Sensor: GR04.280P, Stroke limiters: GR04.330-KIT, Kit of mounting screws: GR07.032-35-KIT
<b>GR07.032-40</b>	G1/8	32	40	346	Mounting bracket: GR06.115, Mounting bracket: GR07.062, Mounting bracket: GR06.084, Mounting bracket: GR06.085, Sensor: GR04.202N, Sensor: GR04.202P, Sensor: GR04.280N, Sensor: GR04.280P, Stroke limiters: GR04.330-KIT, Kit of mounting screws: GR07.032-40-KIT
<b>GR07.032-50</b>	G1/8	32	50	390	Mounting bracket: GR06.115, Mounting bracket: GR07.062, Mounting bracket: GR06.084, Mounting bracket: GR06.085, Sensor: GR04.202N, Sensor: GR04.202P, Sensor: GR04.280N, Sensor: GR04.280P, Stroke limiters: GR04.330-KIT, Kit of mounting screws: GR07.032-50-KIT

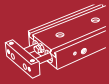

# Linear technology | Short lifting cylinders

## Short stroke cylinders – double-acting

### Dimensions

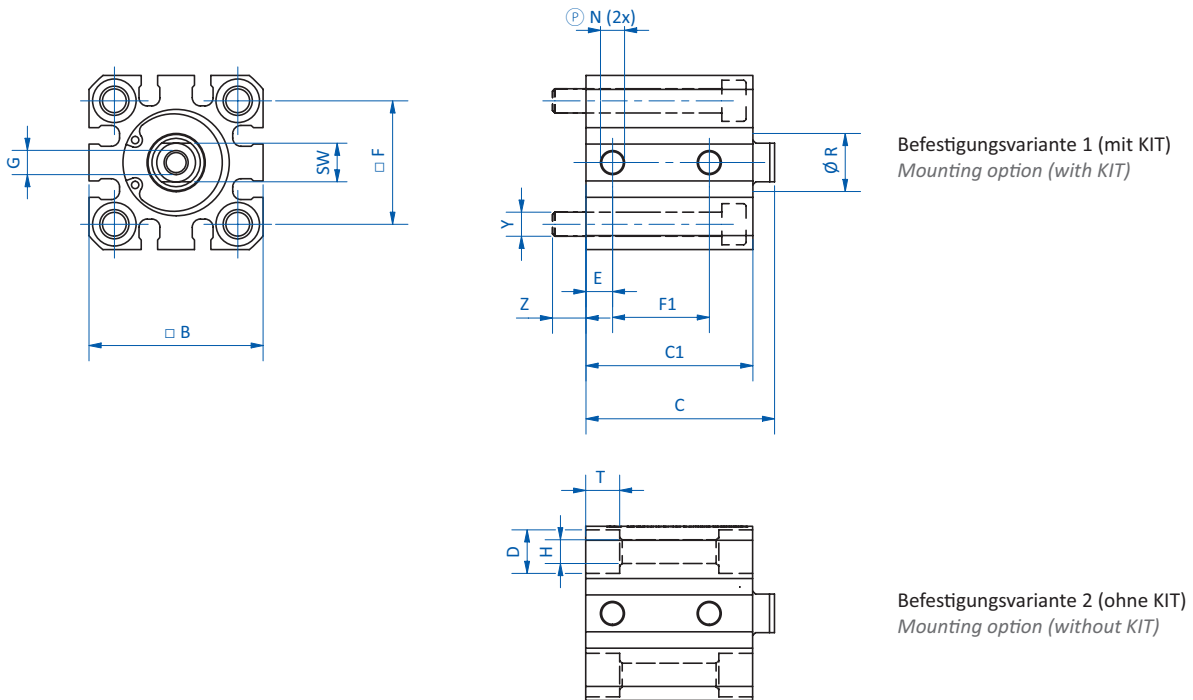

Ⓟ = Compressed air connection

Item no.	□ B [mm]	C [mm]	C1 [mm]	∅ D [mm]	E [mm]	□ F [mm]	F1 [mm]	G	H	SW	N	∅ R [mm]	Z [mm]	Y	T [mm]
GR07.012-5	25	30.5	27	6.5	5	15.5	14.5	M3x6	M4x7	5	M5	6	6.5	M3	4
GR07.012-10	25	35.5	32	6.5	5	15.5	19.5	M3x6	M4x7	5	M5	6	6.5	M3	4
GR07.016-5	29	30.5	27	6.5	5	20	14.5	M4x8	M4x7	6	M5	8	6.5	M3	4
GR07.016-10	29	35.5	32	6.5	5	20	19.5	M4x8	M4x7	6	M5	8	6.5	M3	4
GR07.016-20	29	45.5	42	6.5	5	20	29.5	M4x8	M4x7	6	M5	8	6.5	M3	4
GR07.016-30	29	55.5	52	6.5	5	20	39.5	M4x8	M4x7	6	M5	8	6.5	M3	4
GR07.020-5	36	39	34.5	9	5.5	25.5	20	M5x7	M6x10	8	M5	10	6.5	M5	7
GR07.020-10	36	44	39.5	9	5.5	25.5	25	M5x7	M6x10	8	M5	10	6.5	M5	7
GR07.020-20	36	54	49.5	9	5.5	25.5	35	M5x7	M6x10	8	M5	10	6.5	M5	7
GR07.020-30	36	64	59.5	9	5.5	25.5	45	M5x7	M6x10	8	M5	10	6.5	M5	7
GR07.020-50	36	84	79.5	9	5.5	25.5	65	M5x7	M6x10	8	M5	10	6.5	M5	7
GR07.025-5	40	42.5	37.5	9	5.5	28	21	M6x12	M6x10	10	M5	12	8.5	M5	7
GR07.025-10	40	47.5	42.5	9	5.5	28	26	M6x12	M6x10	10	M5	12	8.5	M5	7
GR07.025-20	40	57.5	52.5	9	5.5	28	36	M6x12	M6x10	10	M5	12	8.5	M5	7
GR07.025-30	40	67.5	62.5	9	5.5	28	46	M6x12	M6x10	10	M5	12	8.5	M5	7
GR07.025-50	40	87.5	82.5	9	5.5	28	66	M6x12	M6x10	10	M5	12	8.5	M5	7
GR07.032-5	45	45	38	9	7.5	34	20	M8x13	M6x10	14	G1/8	16	8.5	M5	7
GR07.032-10	45	50	43	9	7.5	34	25	M8x13	M6x10	14	G1/8	16	8	M5	7
GR07.032-15	45	45	48	9	7.5	34	30	M8x13	M6x10	14	G1/8	16	8	M5	7
GR07.032-20	45	60	53	9	7.5	34	35	M8x13	M6x10	14	G1/8	16	8	M5	7
GR07.032-25	45	65	58	9	7.5	34	40	M8x13	M6x10	14	G1/8	16	8	M5	7
GR07.032-30	45	70	63	9	7.5	34	45	M8x13	M6x10	14	G1/8	16	8	M5	7
GR07.032-35	45	75	68	9	7.5	34	50	M8x13	M6x10	14	G1/8	16	8	M5	7
GR07.032-40	45	80	73	9	7.5	34	55	M8x13	M6x10	14	G1/8	16	8	M5	7
GR07.032-50	45	90	83	9	7.5	34	65	M8x13	M6x10	14	G1/8	16	8	M5	7

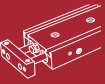

### Compact cylinders with integrated clamp arm



#### Product notes

- > Use to retract vacuum cups while moving the EOAT into a deep cavity
- > Sensors optional

#### Technical data

Item no.	Stroke [mm]	Clamping $\phi$ [mm]	Weight [g]	Accessories
<b>GR07.050</b>	20	10	96	Mounting bracket: GR07.002, Mounting bracket: GR06.100, Mounting bracket: GR07.060, Sensor: GR04.202N, Sensor: GR04.202P, Sensor: GR04.280N, Sensor: GR04.280P
<b>GR07.051</b>	50	14	303	Mounting bracket: GR07.001, Mounting bracket: GR06.109, Mounting bracket: GR07.061, Sensor: GR04.202N, Sensor: GR04.202P, Sensor: GR04.280N, Sensor: GR04.280P, Kit of mounting screws: GR07.020-50-KIT
<b>GR07.052</b>	50	20	552	Mounting bracket: GR07.001, Mounting bracket: GR06.115, Mounting bracket: GR07.062, Sensor: GR04.202N, Sensor: GR04.202P, Sensor: GR04.280N, Sensor: GR04.280P, Stroke limiters: GR04.330-KIT, Kit of mounting screws: GR07.032-50-KIT

#### Application example

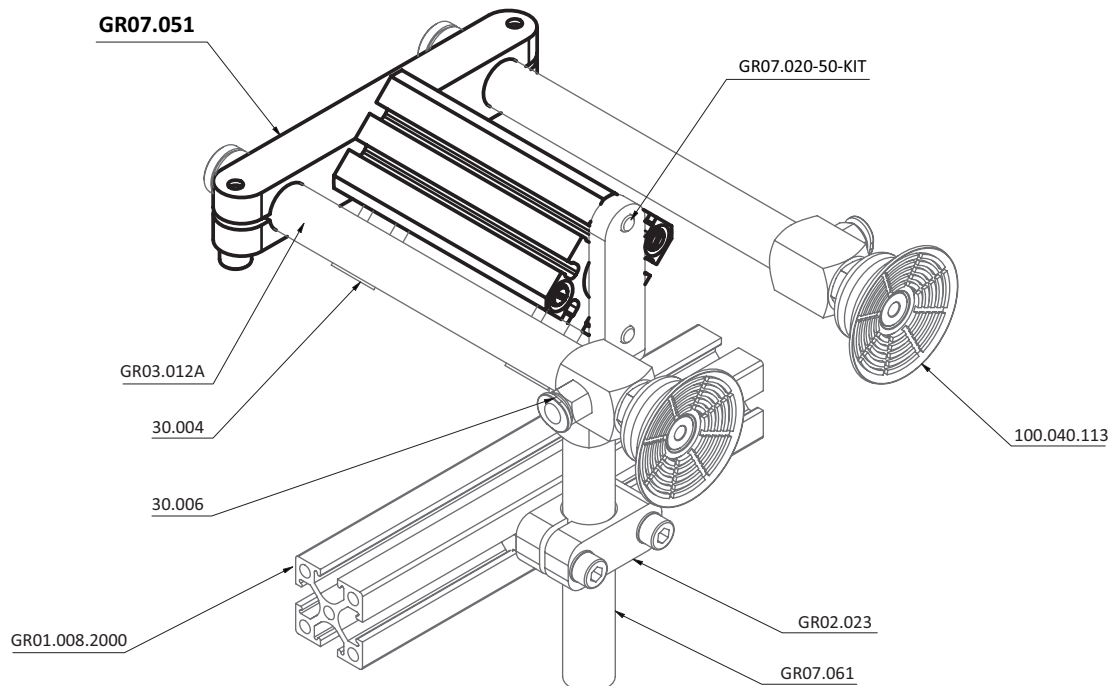

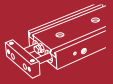

# Linear technology | Short lifting cylinders

Compact cylinders with integrated clamp arm

## Dimensions

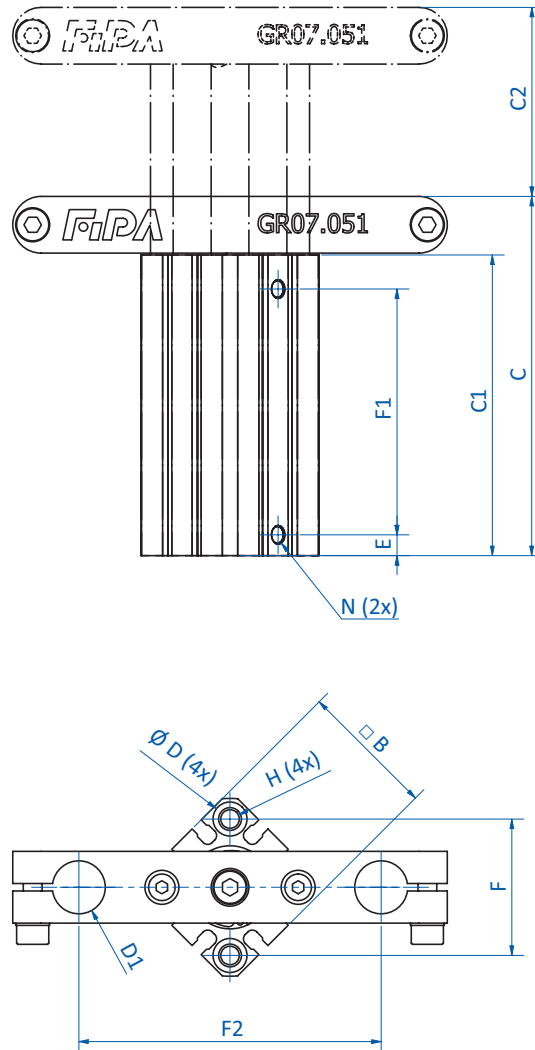

Item no.	B [mm]	C [mm]	C1 [mm]	C2 [mm]	Ø D [mm]	Ø D1 [mm]	E [mm]	F [mm]	F1 [mm]	F2 [mm]	H	N
GR07.050	25	53.5	42	20	6.5	10	5	22	29.5 - 0	55	M4x7	M5
GR07.051	36	95	80	50	9	14	5.5	36	65	80	M6x10	M5
GR07.052	45	101.5	83	50	9	20	5.5	48.1	65	120	M6x10	M5

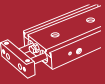

### Dual-piston cylinders – double-acting

**HIGH PRECISION CYLINDER GUIDING, ANTI-TWIST PROTECTION**

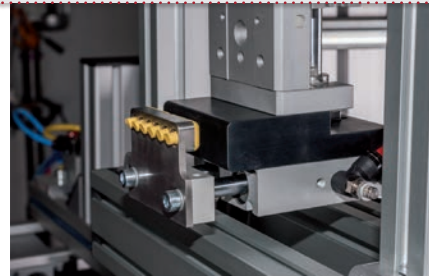
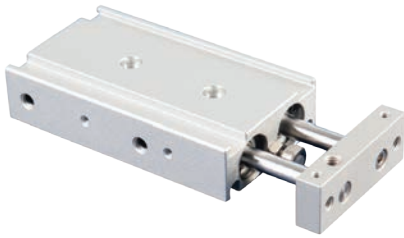

Combination of dual-piston cylinder and guide block

#### Product notes

- > Unit to precisely guide gripper components such as vacuum cups to the workpiece
- > Double-acting, separate compressed air connections for extraction and retraction
- > Sensors for optional detection of piston position (extracted/retracted)
- > PNP and NPN sensors:
  - C-slot (90° angle): GR04.202P, GR04.202N
  - C-slot (straight, short design): GR04.280P, GR04.280N
- > Medium: filtered and oiled/unoiled air

#### Technical data

Item no.	GR07.112-25	GR07.112-50	GR07.112-75	GR07.116-25	GR07.116-50	GR07.116-75	GR07.116-100
Compressed air connection	M5	M5	M5	M5	M5	M5	M5
Operating pressure [bar (psi)]	1 - 7 (14.5 - 101.5)	1 - 7 (14.5 - 101.5)	1 - 7 (14.5 - 101.5)	1 - 7 (14.5 - 101.5)	1 - 7 (14.5 - 101.5)	1 - 7 (14.5 - 101.5)	1 - 7 (14.5 - 101.5)
Piston diameter [mm]	12	12	12	16	16	16	16
Stroke [mm]	25	50	75	25	50	75	100
Operating temperature [°C (°F)]	-5 - 70 (23 - 158)	-5 - 70 (23 - 158)	-5 - 70 (23 - 158)	-5 - 70 (23 - 158)	-5 - 70 (23 - 158)	-5 - 70 (23 - 158)	-5 - 70 (23 - 158)
Weight [g]	180	230	280	290	360	435	510
Suitable sensors	GR04.202N GR04.202P GR04.280N GR04.280P	GR04.202N GR04.202P GR04.280N GR04.280P	GR04.202N GR04.202P GR04.280N GR04.280P	GR04.202N GR04.202P GR04.280N GR04.280P	GR04.202N GR04.202P GR04.280N GR04.280P	GR04.202N GR04.202P GR04.280N GR04.280P	GR04.202N GR04.202P GR04.280N GR04.280P

#### Theoretical cylinder force depending on the working pressure

Working pressure [bar]	Cylinder force [N]			
	GR07.112-xx		GR07.116-xx	
	Move out	Move in	Move out	Move in
1	16	10	35.5	25
1.5	23.5	15	53	38
2	31.5	20	70.5	50.5
3	47	30	106	75.5
4	63	40	141	101
5	78.5	50	176.5	126
6	94	60	212	151
7	110	70	247	176.5

Continued on the next page →

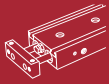

# Linear technology | Dual-piston cylinders

Dual-piston cylinders – double-acting

## Dimensions

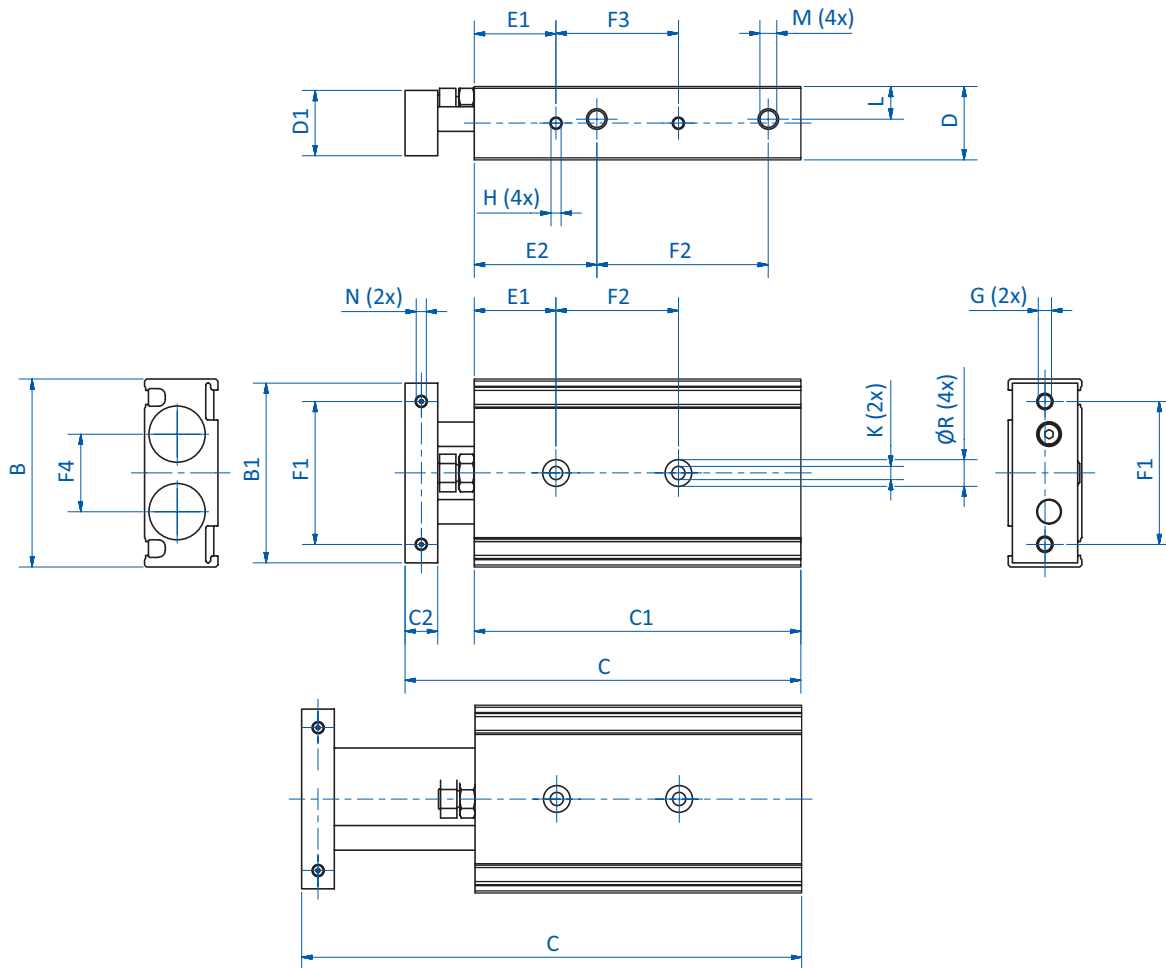

① = Compressed air connection M5

Item no.	GR07.112-25	GR07.112-50	GR07.112-75	GR07.116-25	GR07.116-50	GR07.116-75	GR07.116-100
L [mm]	8.5	8.5	8.5	9.5	9.5	9.5	9.5
B [mm]	46	46	46	58	58	58	58
B1 [mm]	44	44	44	58	58	58	58
C [mm]	97 - 122	122 - 172	147 - 222	104 - 129	129 - 179	154 - 229	179 - 279
C1 [mm]	80	105	130	85	110	135	160
C2 [mm]	8	8	8	10	10	10	10
D [mm]	18	18	18	20	20	20	20
D1 [mm]	16	16	16	18	18	18	18
E1 [mm]	20	20	20	30	30	30	30
E2 [mm]	30	30	30	38.5	38.5	38.5	38.5
F1 [mm]	35	35	35	45	45	45	45
F2 [mm]	42	67	92	38.5	63.5	88.5	114
F3 [mm]	30	40	50	25	35	45	55
F4 [mm]	19	19	19	25	25	25	25
G	M4x0.7	M4x0.7	M4x0.7	M5x0.8	M5x0.8	M5x0.8	M5x0.8
H	M3x4,5	M3x4,5	M3x4,5	M4x5	M4x5	M4x5	M4x5
K	M4	M4	M4	M5	M5	M5	M5
M	M5	M5	M5	M5	M5	M5	M5
N	M3x5	M3x5	M3x5	M4x6	M4x6	M4x6	M4x6
Ø R	6,5x3,3	6,5x3,3	6,5x3,3	8x4,4	8x4,4	8x4,4	8x4,4



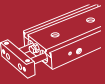

### Guide blocks piston – double-acting

**HIGH PRECISION COMBINATION OF CYLINDER AND LINEAR GUIDING**

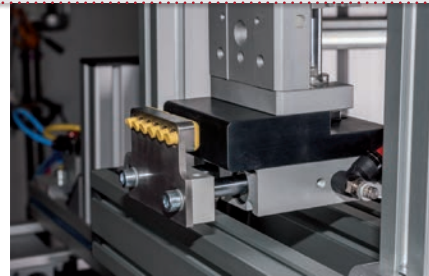

Combination of guide block and dual-piston cylinder

#### Product notes

- > Unit to precisely guide gripper components such as sprue grippers or nippers to the workpiece
- > Double-acting, separate compressed air connections for extraction and retraction
- > Sensors for optional detection of piston position (extracted/retracted)
- > Stroke adjusters available on request
- > Linear guide blocks can also be used to move gripped workpieces more closely together, to prepare the items for example for pick & place by vacuum grippers
- > PNP and NPN sensors:
  - C-slot (90° angle): GR04.202P, GR04.202N
  - C-slot (straight, short design): GR04.280P, GR04.280N
- > Medium: filtered and oiled/non-oiled air

#### Technical data

Item no.	Compressed air connection	Operating pressure [bar (psi)]	Piston diameter [mm]	Stroke [mm]	Operating temperature [°C (°F)]	Weight [g]	Suitable sensors
<b>GR07.208-30</b>	2xM5	1.5 - 7 (21.8 - 101.5)	8	30	-5 - 60 (23 - 140)	190	GR04.202N GR04.202P GR04.280N GR04.280P
<b>GR07.208-50</b>	2xM5	1.5 - 7 (21.8 - 101.5)	8	50	-5 - 60 (23 - 140)	285	GR04.202N GR04.202P GR04.280N GR04.280P
<b>GR07.208-75</b>	2xM5	1.5 - 7 (21.8 - 101.5)	8	75	-5 - 60 (23 - 140)	394	GR04.202N GR04.202P GR04.280N GR04.280P
<b>GR07.216-30</b>	2xM5	1.5 - 7 (21.8 - 101.5)	16	30	-5 - 60 (23 - 140)	585	GR04.202N GR04.202P GR04.280N GR04.280P
<b>GR07.216-50</b>	2xM5	1.5 - 7 (21.8 - 101.5)	16	50	-5 - 60 (23 - 140)	762	GR04.202N GR04.202P GR04.280N GR04.280P
<b>GR07.216-75</b>	2xM5	1.5 - 7 (21.8 - 101.5)	16	75	-5 - 60 (23 - 140)	1,095	GR04.202N GR04.202P GR04.280N GR04.280P
<b>GR07.216-100</b>	2xM5	1.5 - 7 (21.8 - 101.5)	16	100	-5 - 60 (23 - 140)	1,410	GR04.202N GR04.202P GR04.280N GR04.280P
<b>GR07.220-10</b>	2xG1/8	1.5 - 7 (21.8 - 101.5)	20	10	-5 - 60 (23 - 140)	1,050	GR04.202N GR04.202P GR04.280N GR04.280P

Continued on the next page →

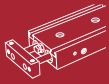

# Linear technology | Guide blocks

## Guide blocks piston – double-acting

### Technical data

Item no.	Compressed air connection	Operating pressure [bar (psi)]	Piston diameter [mm]	Stroke [mm]	Operating temperature [°C (°F)]	Weight [g]	Suitable sensors
<b>GR07.220-30</b>	2xG1/8	1.5 - 7 (21.8 - 101.5)	20	30	-5 - 60 (23 - 140)	1,010	GR04.202N GR04.202P GR04.280N GR04.280P
<b>GR07.220-50</b>	2xG1/8	1.5 - 7 (21.8 - 101.5)	20	50	-5 - 60 (23 - 140)	1,250	GR04.202N GR04.202P GR04.280N GR04.280P
<b>GR07.220-75</b>	2xG1/8	1.5 - 7 (21.8 - 101.5)	20	75	-5 - 60 (23 - 140)	1,630	GR04.202N GR04.202P GR04.280N GR04.280P
<b>GR07.220-100</b>	2xG1/8	1.5 - 7 (21.8 - 101.5)	20	100	-5 - 60 (23 - 140)	2,150	GR04.202N GR04.202P GR04.280N GR04.280P
<b>GR07.220-125</b>	2xG1/8	1.5 - 7 (21.8 - 101.5)	20	125	-5 - 60 (23 - 140)	2,670	GR04.202N GR04.202P GR04.280N GR04.280P
<b>GR07.220-150</b>	2xG1/8	1.5 - 7 (21.8 - 101.5)	20	150	-5 - 60 (23 - 140)	3,190	GR04.202N GR04.202P GR04.280N GR04.280P

### Theoretical cylinder force depending on the working pressure

Working pressure [bar]	Cylinder force [N]					
	GR07.208-xx		GR07.216-xx		GR07.220-xx	
	Move out	Move in	Move out	Move in	Move out	Move in
2	20	15	80	60	126	94
3	30	23	121	91	188	141
4	40	30	161	121	251	188
5	51	38	201	151	314	236
6	61	45	241	181	377	283
7	71	53	281	211	400	330
Effective piston surface [mm <sup>2</sup> ]	101	75	402	302	628	471

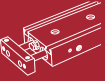

### Dimensions

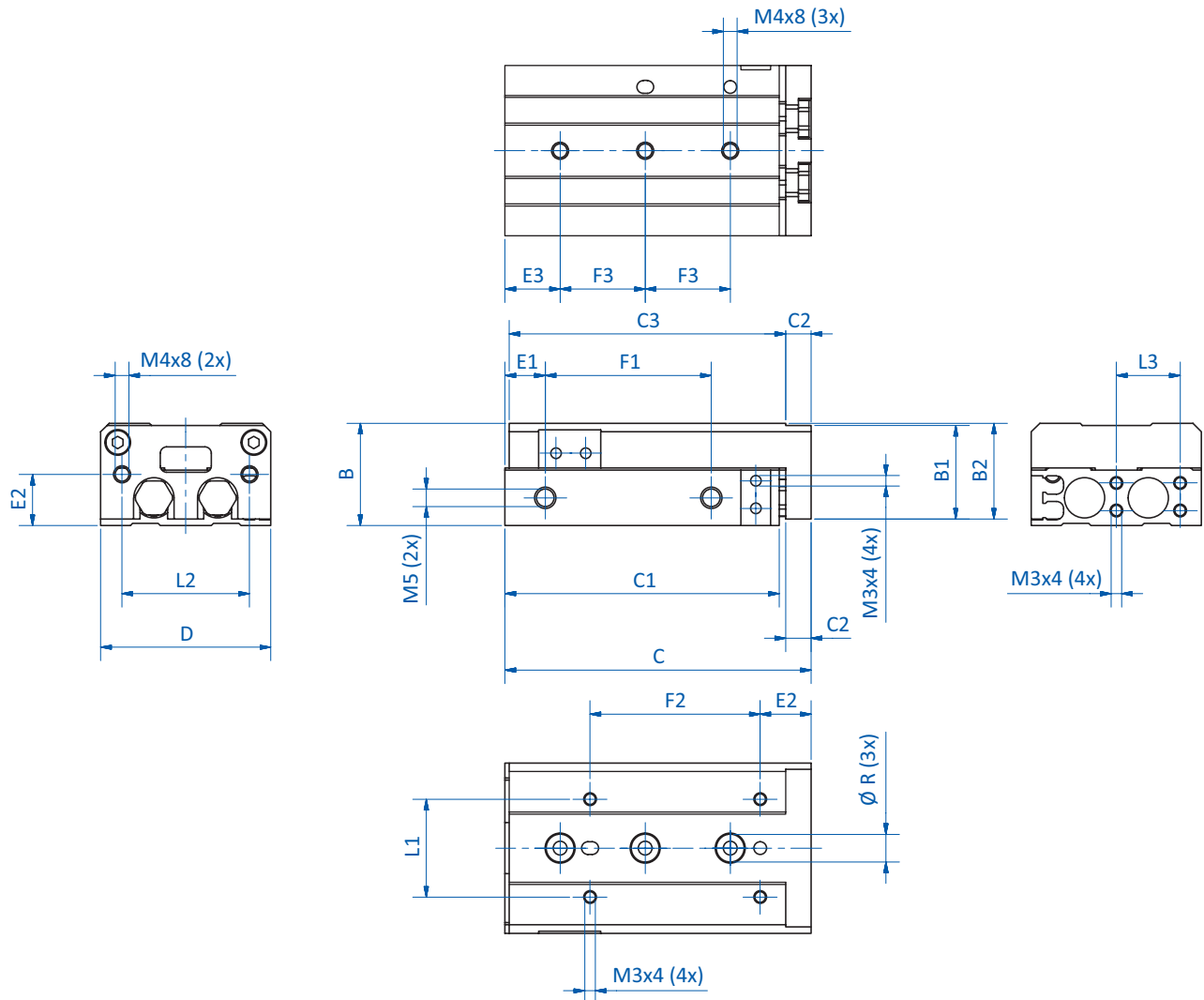

GR07.208-30 | GR07.208-50 | GR07.208-75

Continued on the next page →

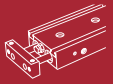

# Linear technology | Guide blocks

Guide blocks piston – double-acting

## Dimensions

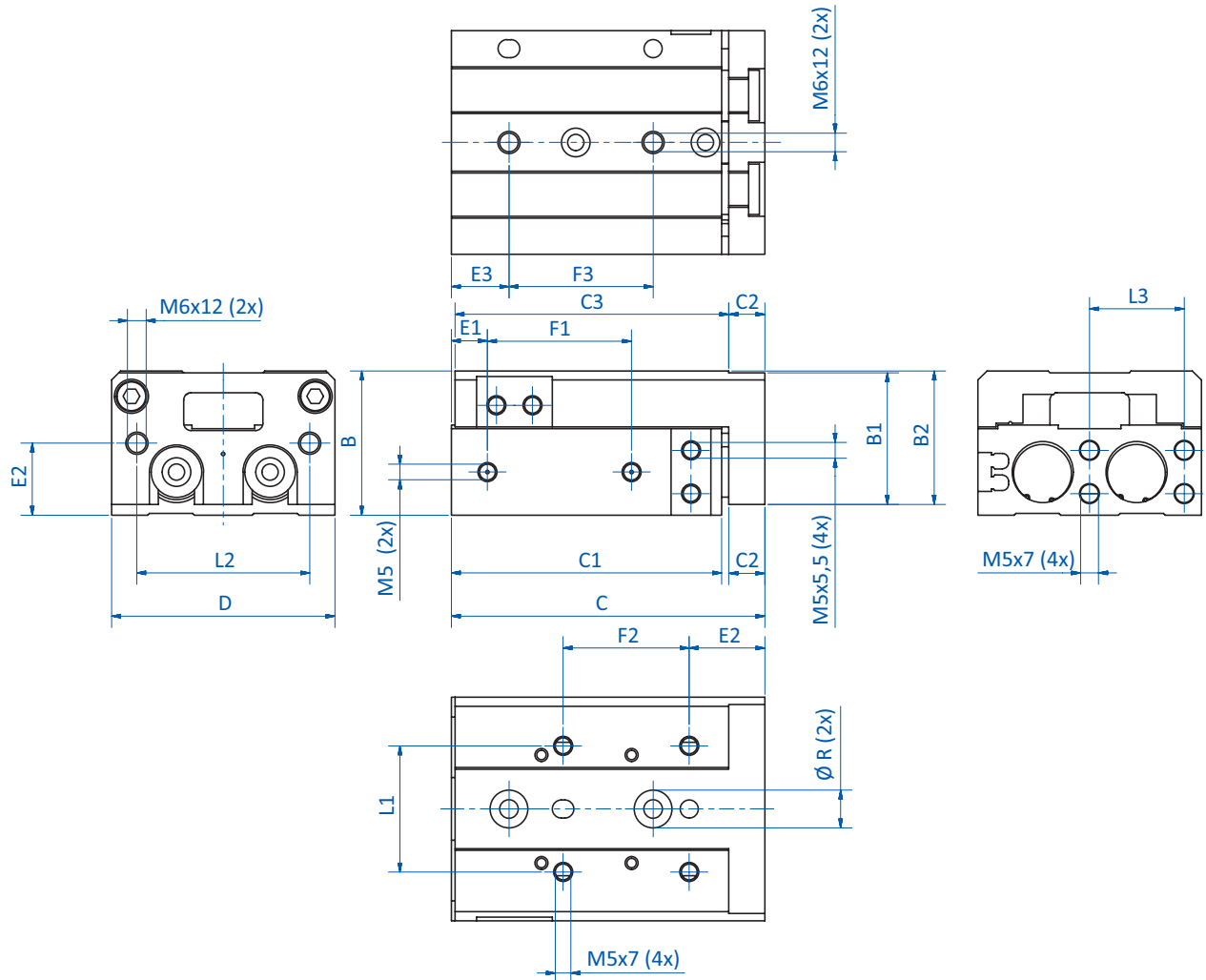

GR07.216-30 | GR07.216-50 | GR07.216-75 | GR07.216-100

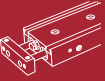

Dimensions

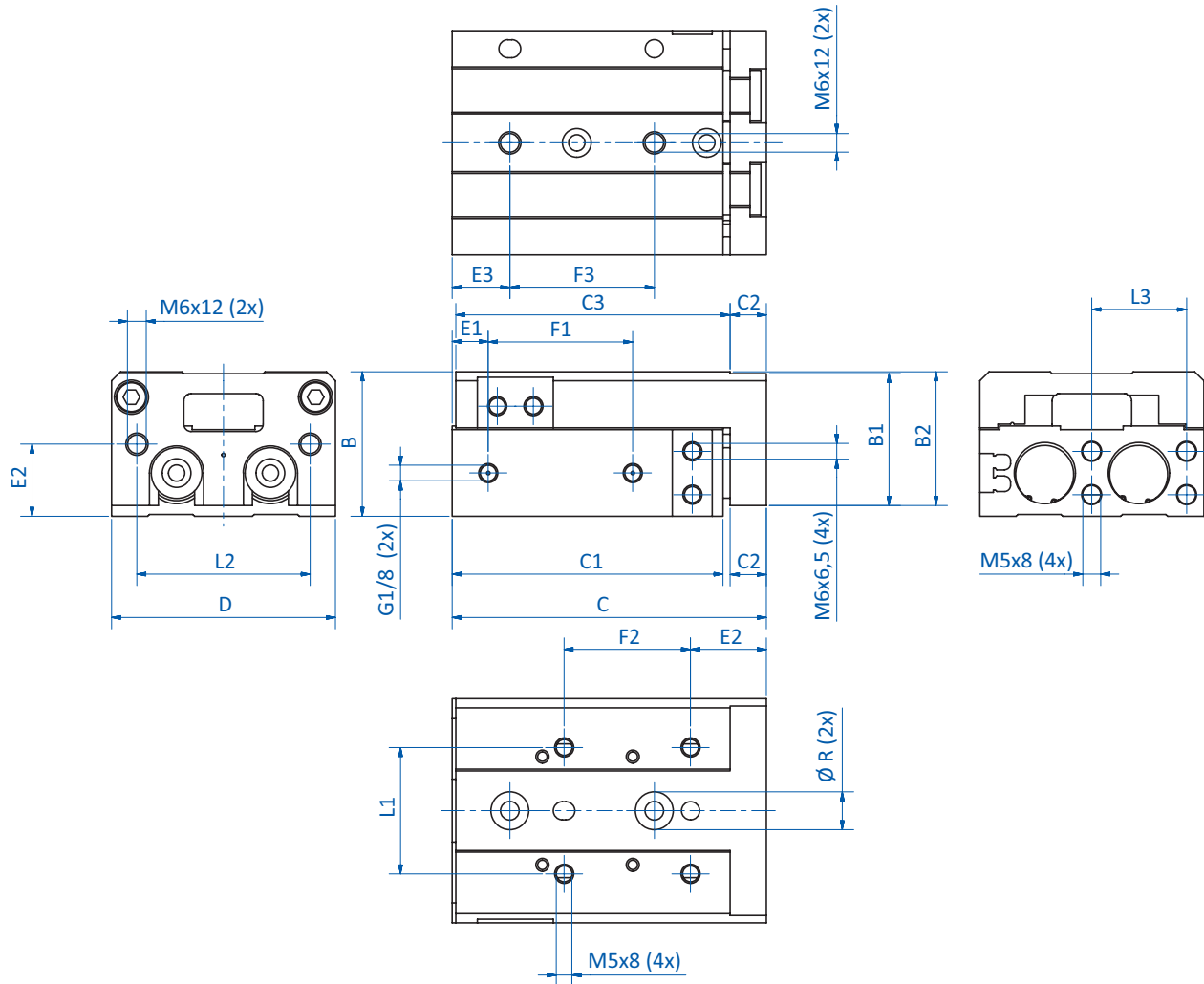

GR07.220-10 | GR07.220-30 | GR07.220-50 | GR07.220-75 | GR07.220-100 | GR07.220-125 | GR07.220-150

Continued on the next page

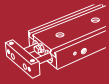

# Linear technology | Guide blocks

## Guide blocks piston – double-acting

Item no.	B [mm]	B1 [mm]	B2 [mm]	C [mm]	C1 [mm]	C2 [mm]	C3 [mm]	D [mm]	E1 [mm]	E2 [mm]	E3 [mm]	F1 [mm]	F2 [mm]	F3 [mm]	L1 [mm]	L2 [mm]	L3 [mm]	Ø R [mm]
<b>GR07.208-30</b>	24	22	22.5	72 - 102	64.5	6	65	40	9.5	12	13	39	40	20	23	30	15	7
<b>GR07.208-50</b>	24	22	22.5	108 - 158	100.5	6	101	40	24.5	12	20	60	38	23	23	30	15	7
<b>GR07.208-75</b>	24	22	22.5	158 - 233	150.5	6	151	40	38.5	12	27	96	50	28	23	30	15	7
<b>GR07.216-30</b>	40	36.5	37	87 - 117	75	10	76	62	10	20 - 21	16	40	35	40	35	48	26	10.5
<b>GR07.216-50</b>	40	36.5	37	112 - 162	100	10	101	62	15	20 - 21	21	60	30	30	35	48	26	10.5
<b>GR07.216-75</b>	40	36.5	37	162 - 237	150	10	151	62	40	20 - 21	26	85	55	35	35	48	26	10.5
<b>GR07.216-100</b>	40	36.5	37	210 - 310	198	10	199	62	55	20 - 21	39	118	65	35	35	48	26	10.5
<b>GR07.220-10</b>	50	45.5	46	97 - 107	81.5	13	83	76	10	25 - 27	15	44	50	45	46	58	30 (2x)	11
<b>GR07.220-30</b>	50	45.5	46	97 - 107	81.5	13	83	76	10	25 - 27	15	44	50	45	46	58	30 (2x)	11
<b>GR07.220-50</b>	50	45.5	46	122 - 172	106.5	13	108	76	10	25 - 27	15	69	35	35	46	58	30 (2x)	11
<b>GR07.220-75</b>	50	45.5	46	161 - 236	145.5	13	147	76	10	25 - 27	19	108	60	35	46	58	30 (2x)	11
<b>GR07.220-100</b>	50	45.5	46	214 - 314	198.5	13	200	76	58	25 - 27	37	113	70	35	46	58	30 (2x)	11
<b>GR07.220-125</b>	50	45.5	46	268 - 393	252.2	13	254	76	70	25 - 27	41	155	70	38	46	58	30 (2x)	11
<b>GR07.220-150</b>	50	45.5	46	320 - 304.5	304.5	13	306	76	87	25 - 27	19	190	80	44	46	58	30 (2x)	11

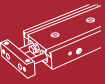

## Guide blocks, extra narrow design – double-acting



### Product notes

- > Unit to precisely guide gripper components such as sprue grippers or nippers to the workpiece
  - > Extra narrow construction for space-saving assembly
  - > Optional position monitoring through detection of piston position
  - > Principle of operation: double-acting
  - > Extension cables for sensors:
    - 20.503: 3-pole M8, straight, length 2,500 mm, open wire
    - 20.507: 3-pole M8, straight, length 2,000 mm, open wire
    - 20.570: 3-pole M8, length 1,500 mm, end with plug 3-pole M8
  - > PNP and NPN sensors:
    - C-slot (90° angle): GR04.202P, GR04.202N
    - C-slot (straight, short design): GR04.280P, GR04.280N
- Other strokes available on request

### Technical data

Item no.	Operating pressure [bar (psi)]	Piston diameter [mm]	Stroke [mm]	Piston speed [mm/sec]	Operating temperature [°C (°F)]	Weight [g]	Accessories
<b>GR07.506-10</b>	1.2 - 7 (17.4 - 101.5)	6	10	50 - 500	-5 - 60 (23 - 140)	70	
<b>GR07.506-20</b>	1.2 - 7 (17.4 - 101.5)	6	20	50 - 500	-5 - 60 (23 - 140)	80	
<b>GR07.506-30</b>	1.2 - 7 (17.4 - 101.5)	6	30	50 - 500	-5 - 60 (23 - 140)	100	
<b>GR07.510-10</b>	1.2 - 7 (17.4 - 101.5)	10	10	50 - 500	-5 - 60 (23 - 140)	125	
<b>GR07.510-20</b>	1.2 - 7 (17.4 - 101.5)	10	20	50 - 500	-5 - 60 (23 - 140)	150	
<b>GR07.510-30</b>	1.2 - 7 (17.4 - 101.5)	10	30	50 - 500	-5 - 60 (23 - 140)	170	
<b>GR07.516-10</b>	1.2 - 7 (17.4 - 101.5)	16	10	50 - 500	-5 - 60 (23 - 140)	230	
<b>GR07.516-20</b>	1.2 - 7 (17.4 - 101.5)	16	20	50 - 500	-5 - 60 (23 - 140)	260	
<b>GR07.516-30</b>	1.2 - 7 (17.4 - 101.5)	16	30	50 - 500	-5 - 60 (23 - 140)	290	

Continued on the next page →

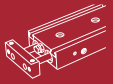

# Linear technology | Guide blocks

Guide blocks, extra narrow design – double-acting

## Dimensions

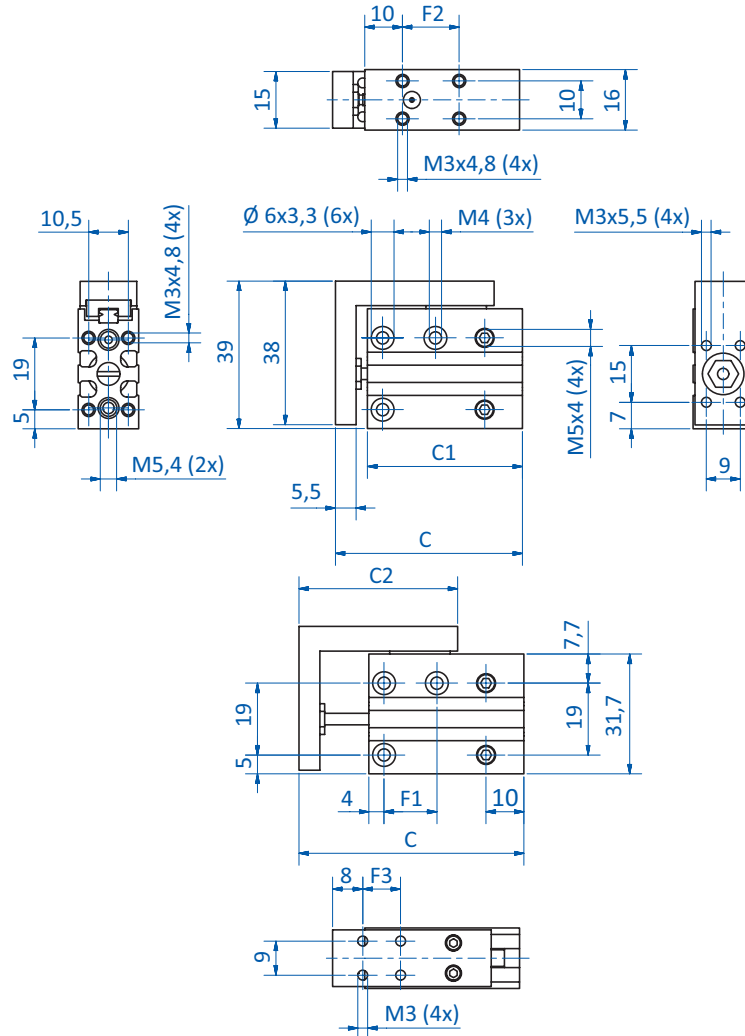

GR07.506-10 | GR07.506-20 | GR07.506-30



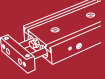

Dimensions

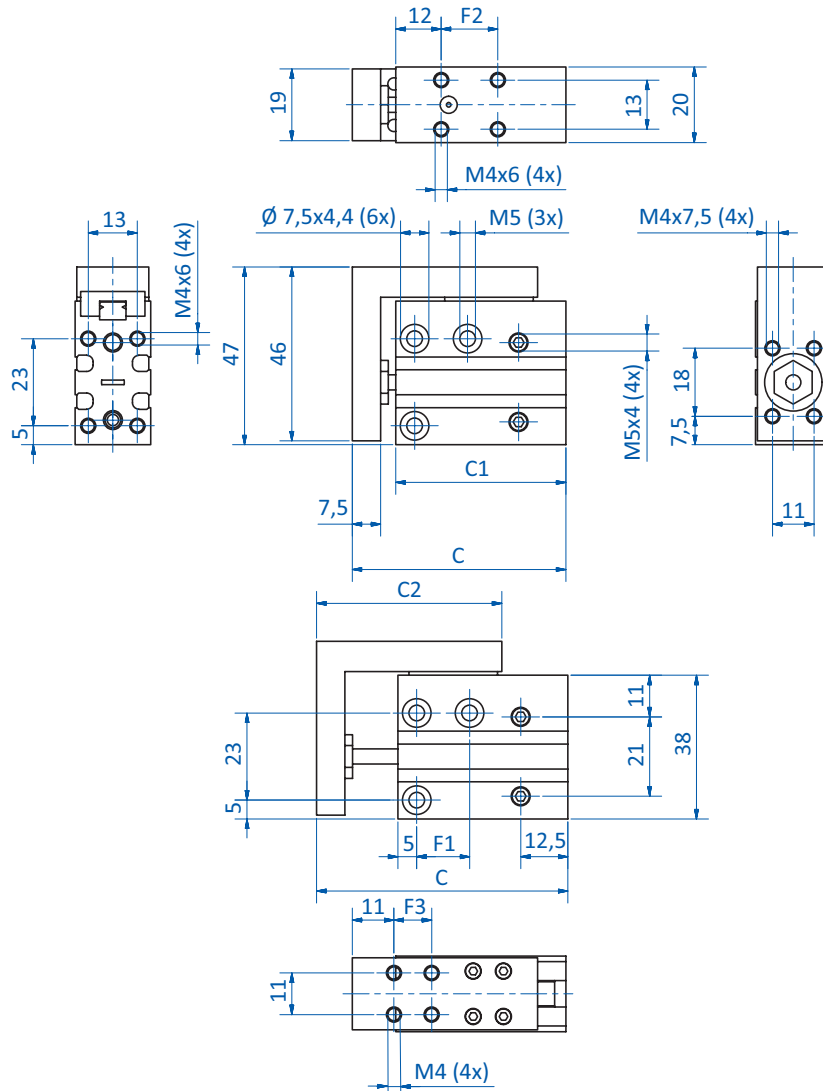

GR07.510-10 | GR07.510-20 | GR07.510-30

Continued on the next page →

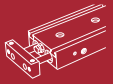

# Linear technology | Guide blocks

Guide blocks, extra narrow design – double-acting

## Dimensions

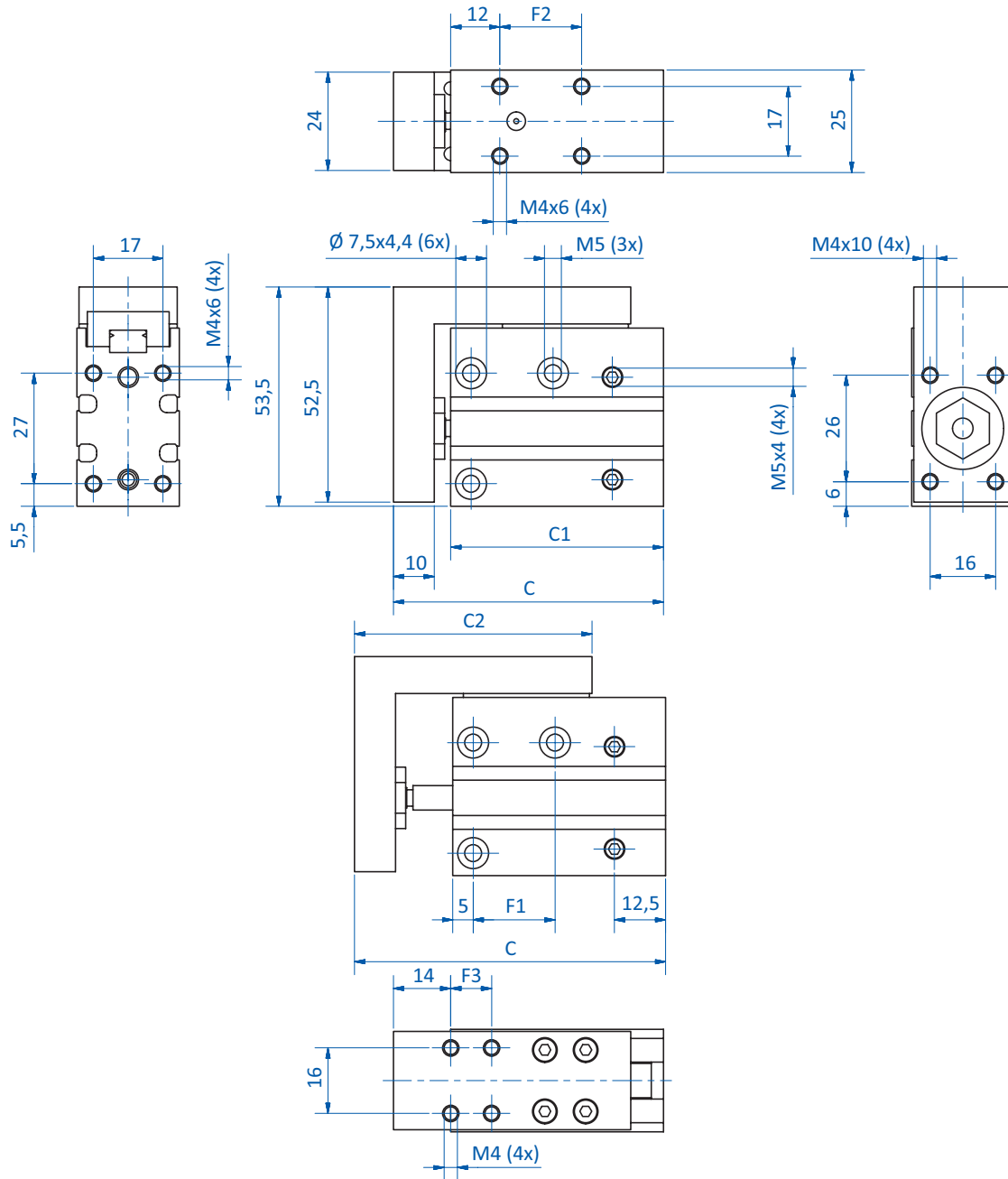

GR07.516-10 | GR07.516-20 | GR07.516-30

Item no.	C [mm]	C1 [mm]	C2 [mm]	F1 [mm]	F2 [mm]	F3 [mm]
GR07.506-10	49.5 - 59.5	41	42	14	15	10
GR07.506-20	51 - 52	51	52	24	25	20
GR07.506-30	69.5 - 99.5	61	62	30	35	30
GR07.510-10	56.5 - 66.5	45	49	14	15	10
GR07.510-20	66.5 - 86.5	55	59	24	25	20
GR07.510-30	76.5 - 106.5	65	69	30	35	30
GR07.516-10	66 - 76	52	58	20	20	10
GR07.516-20	76 - 96	62	68	30	30	20
GR07.516-30	86 - 116	72	78	40	40	30

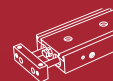

Rotary units

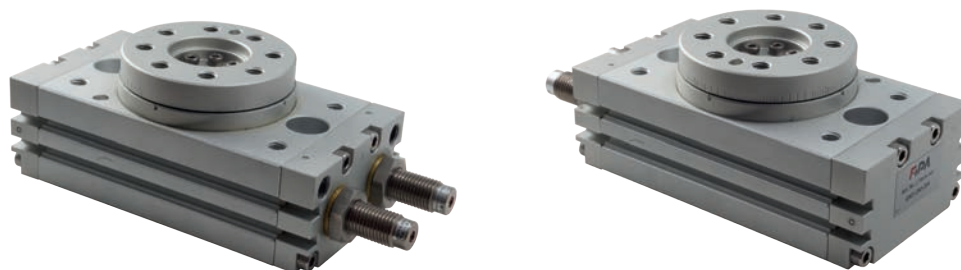

**Product notes**

- > Locating hole for precise assembly
- > Wide operating range of 0°-190° (adjustable)
- > Compact integration with central feed-through for piping or cables
- > Optional shock absorbers for increased service life
- > Optional sensors ensure reliable process

**Technical data**

Item no.	Piston diameter [mm]	Connection thread	Max. operating pressure [bar (psi)]	Design	Operating temperature [°C (°F)]	Weight [g]
GR07.240-12	12	M5	7 (101.5)	with Rubber buffer	0 - 60 (32 - 140)	250
GR07.240-16	16	M5	10 (145)	with Rubber buffer	0 - 60 (32 - 140)	600
GR07.240-16R	16	M5	6 (87)	with Shock absorber	0 - 60 (32 - 140)	610
GR07.240-20	20	G1/8	10 (145)	with Rubber buffer	0 - 60 (32 - 140)	1,240
GR07.240-20R	20	G1/8	6 (87)	with Shock absorber	0 - 60 (32 - 140)	1,310
GR07.240-25	25	G1/8	10 (145)	with Rubber buffer	0 - 60 (32 - 140)	2,100
GR07.240-25R	25	G1/8	6 (87)	with Shock absorber	0 - 60 (32 - 140)	2,120
GR07.240-32	32	G1/8	10 (145)	with Rubber buffer	0 - 60 (32 - 140)	4,180
GR07.240-32R	32	G1/8	6 (87)	with Shock absorber	0 - 60 (32 - 140)	4,190
GR07.240-40	40	G1/8	10 (145)	with Rubber buffer	0 - 60 (32 - 140)	7,670
GR07.240-40R	40	G1/8	6 (87)	with Shock absorber	0 - 60 (32 - 140)	7,720

**Suitable sensors**

- > GR04.280P: 90° angled PNP
- > GR04.280N: 90° angled NPN
- > GR04.202P: straight PNP
- > GR04.202N: straight NPN

Continued on the next page →

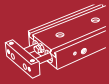

### Model selection

#### Ordering exampl:

GR07.240-16 = Piston diameter 16 mm with Rubber buffer  
 GR07.240-16R = Piston diameter 16 mm with Shock absorber

Item	Piston diameter	Type
GR07.240	-12 = 12 mm	<b>without</b> = with Rubber buffer
	-16 = 16 mm	<b>R</b> = with Shock absorber
	-20 = 20 mm	
	-25 = 25 mm	
	-32 = 32 mm	
	-40 = 40 mm	

### Torque

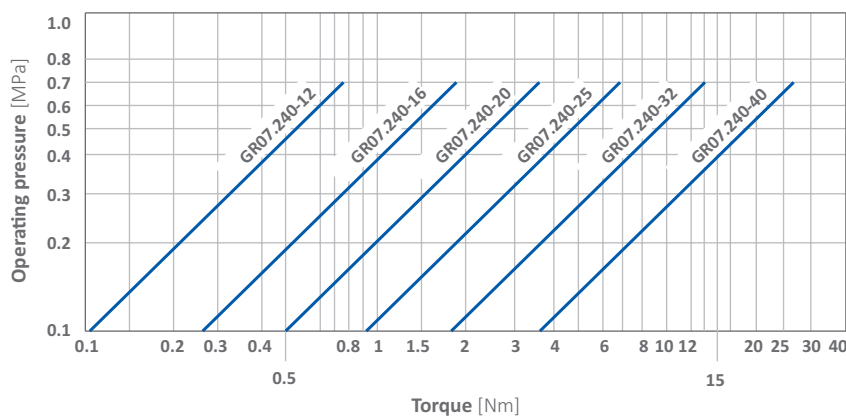

### Allowable loads

Set the load and moment to be applied to the table within the allowable values shown in the table below.  
 (Values outside of limitations will cause excessive play, deteriorate accuracy, and shorten service life.)

Item no.	Allowable radial load [N]	Allowable thrust load [N]		Allowable moment [Nm]
		(a)	(b)	
GR07.240-12	54	71	71	1.5
GR07.240-16	78	74	78	2.4
GR07.240-20	196	197	363	5.3
GR07.240-25	314	296	451	9.7
GR07.240-32	390	493	708	18
GR07.240-40	543	740	1009	25

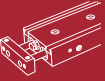

Dimensions

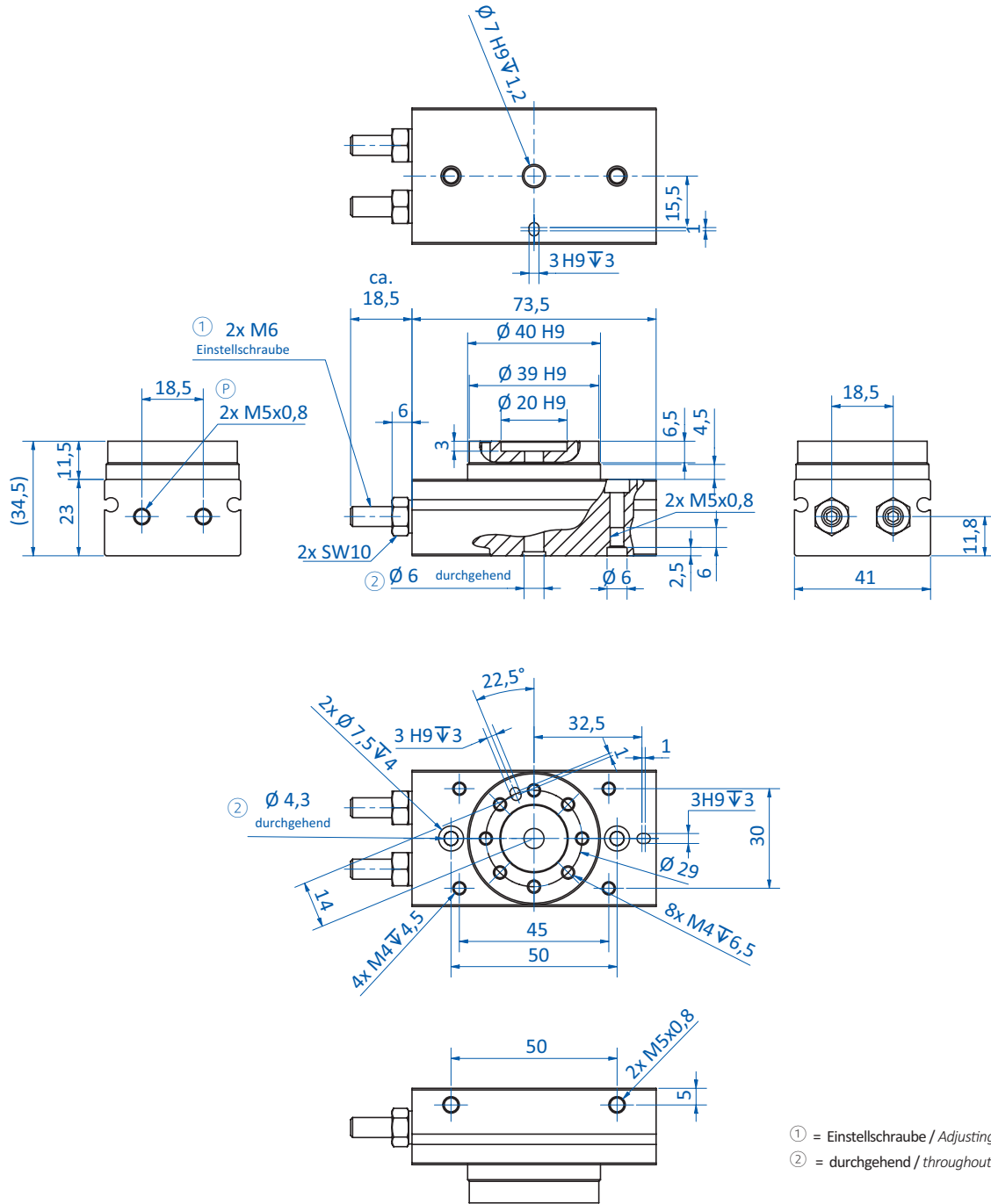

GR07.240-12

Ⓟ = Compressed air connection

- ① = Einstellschraube / Adjusting bolt
- ② = durchgehend / throughout

Continued on the next page →

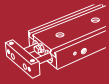

### Dimensions

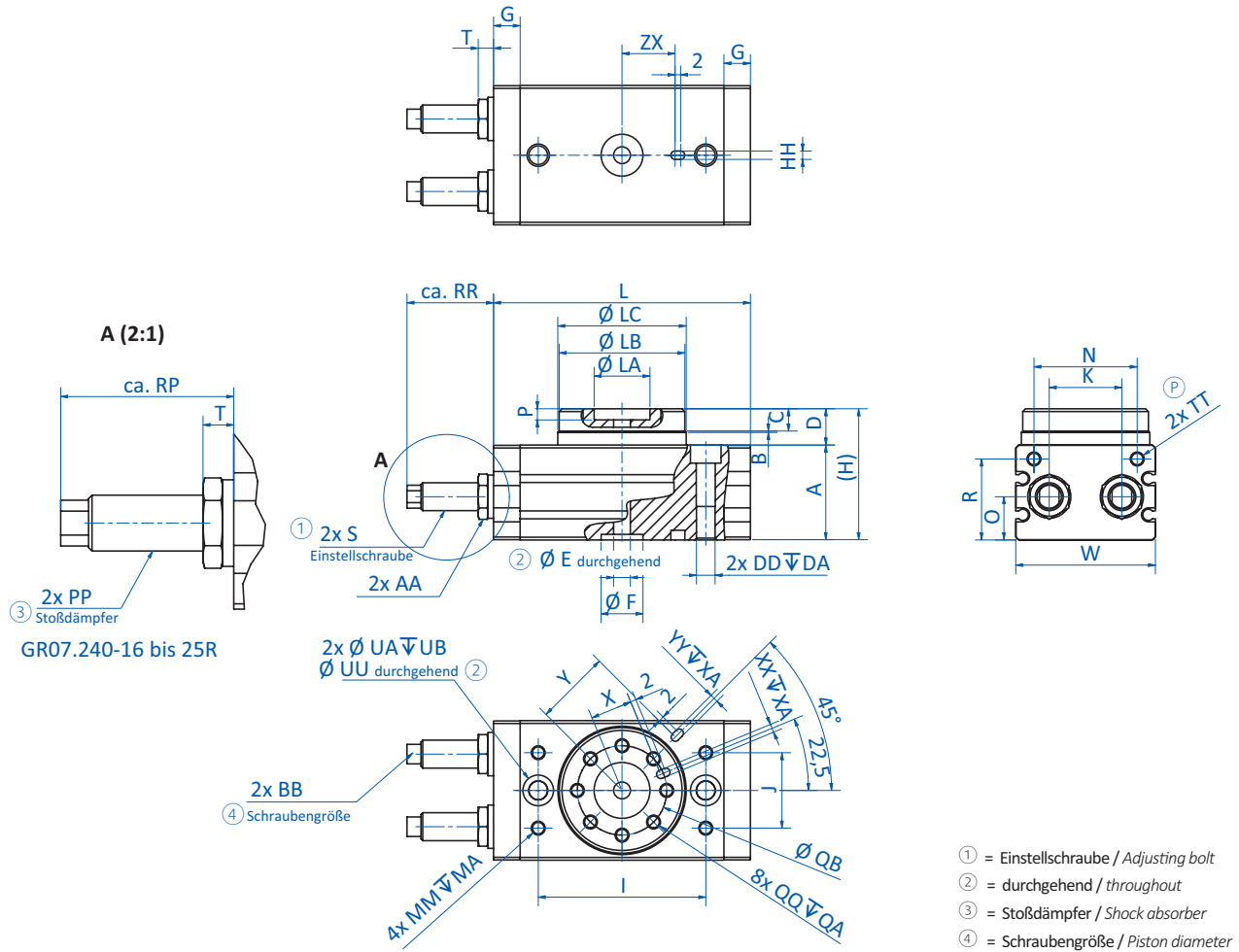

Code	A	AA	B	BB	C	D	DA	DD	E	F	G	H	HH	I	J	K	L	LA	LB	LC	MA	MM	N
-16	34	14	4,5	7	8	13	12	M8×1,25	6	15H9	9,5	47	3H9×3,5	60	27	26	92	20H9	45h9	46h9	8	M5×0,8	37
-20	40	17	6,5	7	10	17	15	M10×1,5	10	22H9	12	57	4H9×4,5	84	37	32	127	32H9	65h9	67h9	8	M6×1	54
-25	46	22	7,5	8	12	20	18	M12×1,75	13	26H9	15,5	66	5H9×5,5	100	50	37	152	35H9	75h9	77h9	8	M8×1,25	63

Code	O	P	PP	QA	QB	QQ	R	RP	RR	S	T	TT	UA	UB	UU	W	X	XA	XX	Y	YA	YY	ZX
-16	15.5	4	FK-1008L-S	8	32	M5×0,8	29	29	31	M10×1,0	5,5	M5×0,8	11	6,5	6,8	50	15	3,5	3H9	27	3,5	3H9	19
-20	19.5	4,5	FK-1008L-S	10	48	M6×1,0	33	23.5	26	M10×1,0	4,5	G1/8	14	8,5	8,6	70	23	4,5	4H9	39	4,5	4H9	28
-25	22	5	FK-1412L-S	12	55	M8×1,25	37.5	33	31.2	M14×1,5	7,5	G1/8	18	10,5	10,5	80	26,5	5,5	5H9	45	5,5	5H9	33

Code = Kolbendurchmesser / Piston diameter

**GR07.240-16 | GR07.240-16R | GR07.240-20 | GR07.240-20R | GR07.240-25 | GR07.240-25R**

Ⓟ = Compressed air connection

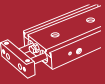

Dimensions

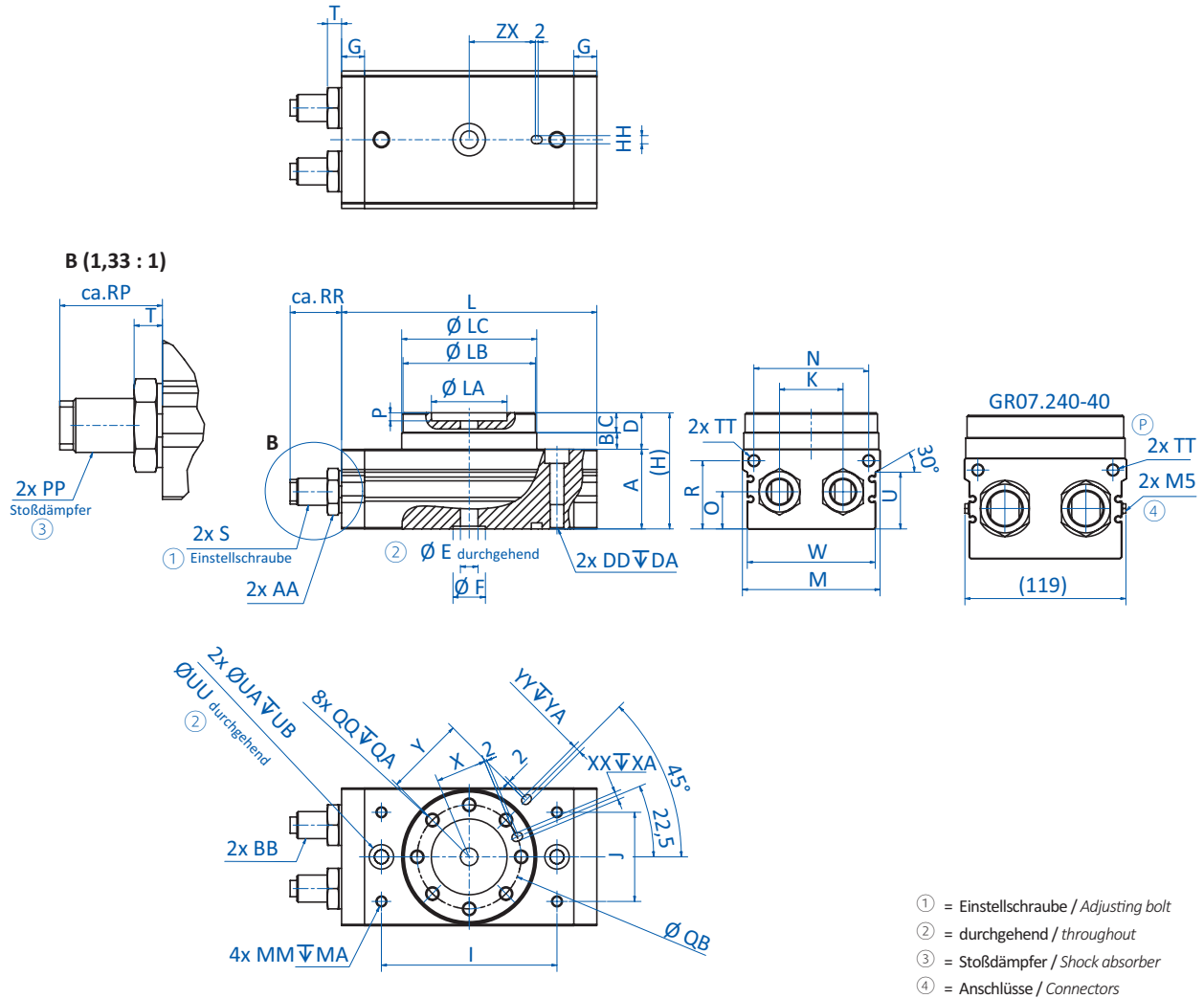

Code	A	AA	B	BB	C	D	DA	DD	E	F	G	H	HH	I	J	K	L	LA	LB	LC	M	MA
-32	59	30	12	Bolt width 12	14,5	27	18	M12×1,75	13	24H9	17	86	6H9×4,5 dp	130	66	47	189	56H9	98h9	100h9	102	10
-40	74	36	15	Bolt width 21	16,5	32	25	M16×2,0	24	32H9	24	106	8H9×6,5 dp	150	80	60	240	64H9	116h9	118h9	120	13

Code	MM	N	O	P	PP	QA	QB	QQ	R	RP	RR	S	T	TT	U	UA	UB	UU	W	X	XA
-32	M8×1,25	85	27,5	6	FK-2016L-S	14,5	77	M10×1,5	50,5	46	38,1	M20×1,5	10,5	G1/8	42	18	10,5	10,5	95	37,5	6,5
-40	M12×1,75	100	37	9	FK-2725L-S	16,5	90	M12×1,75	65,5	68	45	M27×1,5	7	G1/8	57	20	12,5	14,2	113	44	8,5

Code	XX	Y	YA	YY	ZX
-32	6H9	59	4,5	6H9	49
-40	8H9	69	4,5	8H9	54

Code = Kolbendurchmesser / Piston diameter

GR07.240-32 | GR07.240-32R | GR07.240-40 | GR07.240-40R

Ⓟ = Compressed air connection

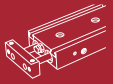

### Elbow arm for short stroke cylinders



#### Product notes

- > Easily mount short stroke cylinders to any gripper system
- > Choose extension tube length as necessary
- > Suitable kits of mounting screws not included in the scope of delivery. Please order separately: e.g. GR07.032-20-KIT for cylinder GR07.032-20

#### Technical data

Item no.	Thread	Suitable for	Weight [g]
GR06.080	M12x1	GR07.012-*	9.1
GR06.081	M12x1	GR07.016-*	11.4
GR06.082	M17x1	GR07.020-*	25.2
GR06.083	M17x1	GR07.025-*	30.3
GR06.084	M17x1	GR07.032-*	36.5
GR06.085	M27x1	GR07.032-*	45.3

#### Dimensions

B [mm]	F [mm]	D [mm]	G1	G2
25	15.5	4	M3x0.5	M12x1
29	20	4	M3x0.5	M12x1
36	25.5	6	M5x0.8	M17x1
40	28	6	M5x0.8	M17x1
45	34	6	M5x0.8	M17x1
45	34	6	M5x0.8	M27x1

#### Dimensions

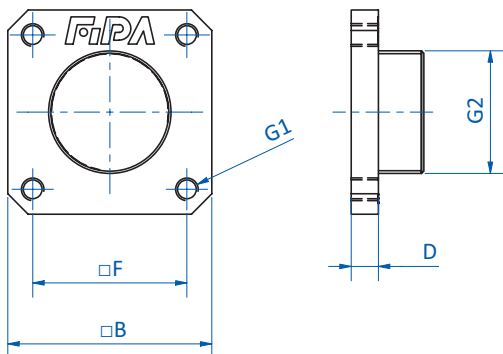

#### Application example

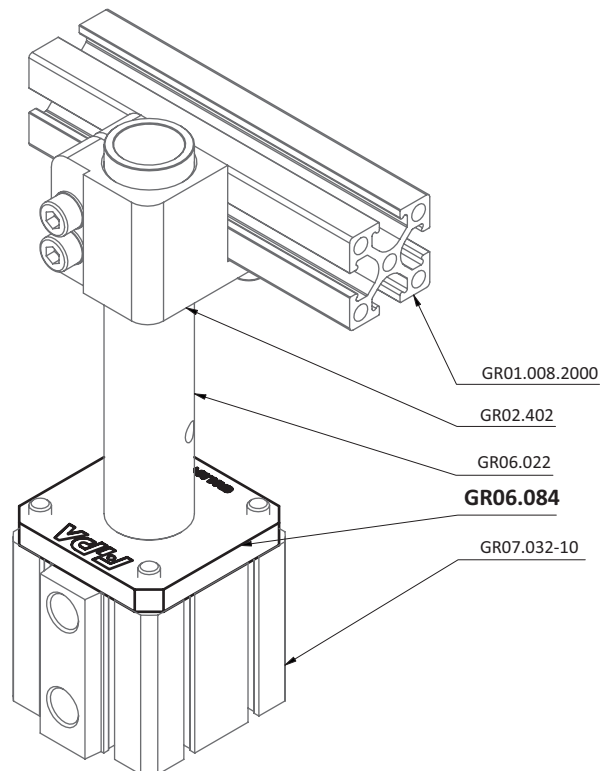



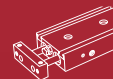

### Elbow arm for short stroke cylinders – rigid



#### Product notes

- > Easily mount short stroke cylinders to any gripper system
- > Suitable kits of mounting screws not included in the scope of delivery. Please order separately: e.g. GR07.032-20-KIT for cylinder GR07.032-20

#### Technical data

Item no.	Clamping $\varnothing$ [mm]	Length [mm]	Weight [g]	Suitable for
GR06.100	10	30	9	GR07.012-*
GR06.109	20	50	37	GR07.020-*
GR06.115	20	50	41	GR07.032-*

#### Dimensions

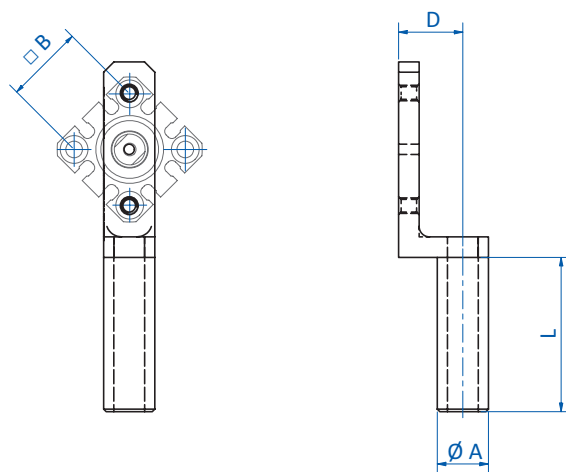

Item no.	$\varnothing A$ [mm]	B [mm]	D [mm]	L [mm]
GR06.100	10	15.5	12.5	30
GR06.109	20	25.5	20	50
GR06.115	20	34	20	50

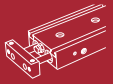

### Elbow arm for short stroke cylinders – swivel

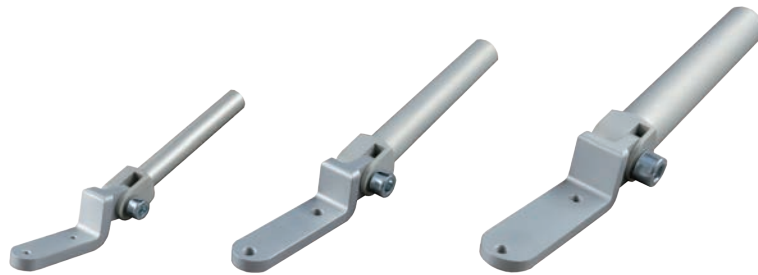

#### Product notes

- > Easily mount short stroke cylinders to any gripper system
- > Suitable kits of mounting screws not included in the scope of delivery. Please order separately: e.g. GR07.032-20-KIT for cylinder GR07.032-20

#### Technical data

Item no.	Clamping $\varnothing$ [mm]	Length [mm]	Weight [g]	Suitable for
GR07.060	10	60	24	GR07.012-*
GR07.061	14	80	44	GR07.020-*
GR07.062	20	100	96	GR07.032-*

#### Dimensions

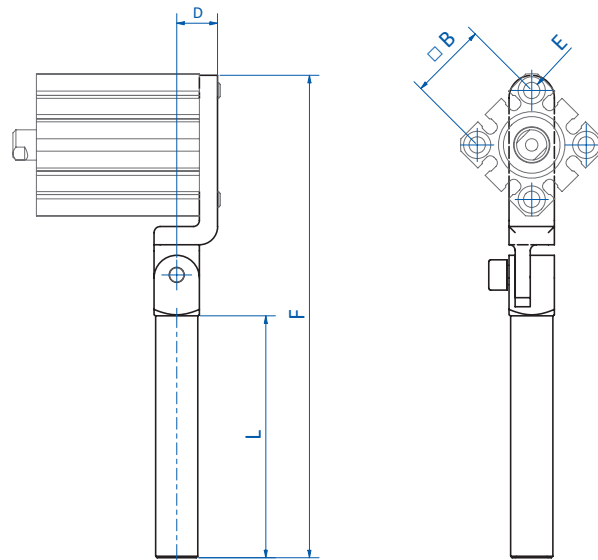

Item no.	$\varnothing A$ [mm]	B [mm]	D [mm]	E	F [mm]	L [mm]
GR07.060	10	15.6	15	M3	124	60
GR07.061	14	25.5	13.5	M5	159.5	80
GR07.062	20	34	16	M5	193	100

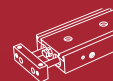

### Fittings for compact cylinders



#### Product notes

- > Integration of compact cylinders into gripper systems
- > Compatible with all compact cylinders complying with ISO 21287 standards

#### Technical data

Item no.	Weight [g]
GR07.001	125
GR07.002	52

#### Dimensions

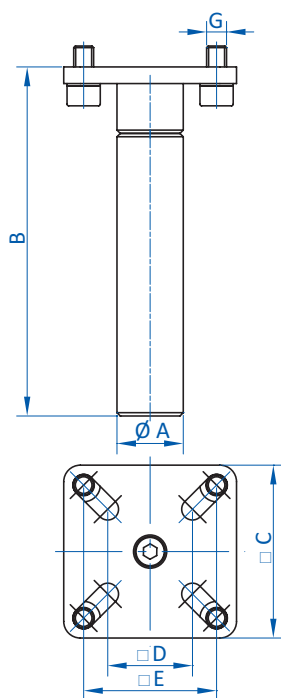

Item no.	∅ A [mm]	B [mm]	□ C [mm]	□ D [mm]	□ E [mm]	G
GR07.001	20	105	52	25.5	40	M6
GR07.002	14	105	29	15.5	20	M4

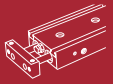

### Pressure plates

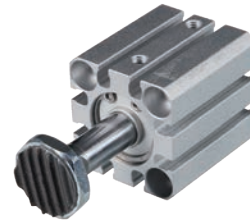
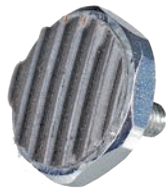

### Product notes

- > Pressure plates with threads e.g. for screwing into short lifting cylinders as gripping or holding tools
- > Grooved natural rubber pad

### Technical data

Item no.	Connection	Weight [g]
GR07.196	M5	12

### Dimensions

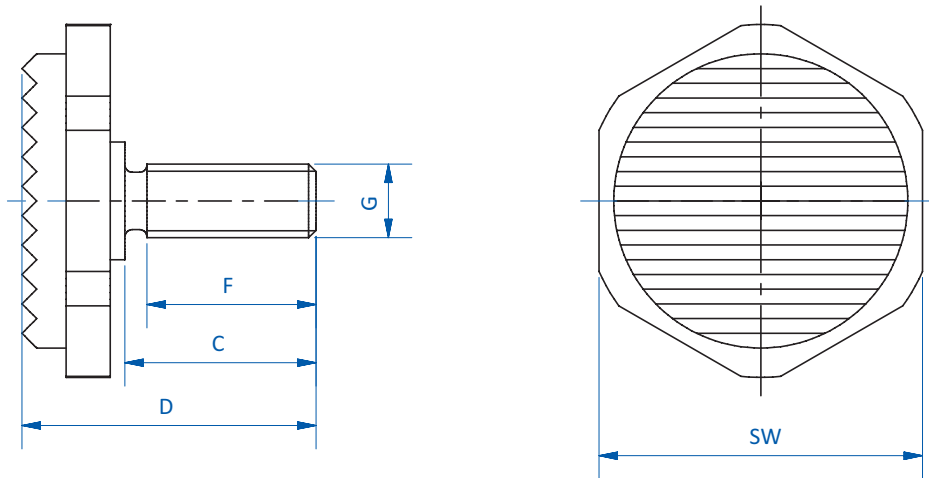

Item no.	SW	C [mm]	D [mm]	F [mm]	G
GR07.196	22	13	20	11.5	M5

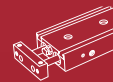

Elbow connectors AG – SZ-WAA



Technical data

Item no.	Material	Weight [g]
GR07.010	Aluminum	12
GR07.011	Aluminum	46
GR07.012	Aluminum	47
GR07.013	Aluminum	49

Dimensions

G1 (female)	G2 (male)	A [mm]	C [mm]	□ D [mm]
G1/8	M5	20	26	16
G1/4	M6	33	43	25
G1/4	M8	33	43	25
G1/4	G1/8	25	35	20

Dimensions

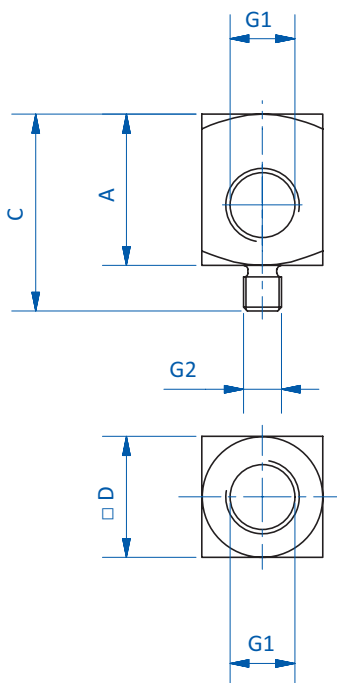



<b>Cobot Smart Gripper</b> .....	<b>342</b>
<b>Area gripper with plug-in vacuum cups</b> .....	<b>351</b>
<b>Area gripper with sealing foam</b> .....	<b>347</b>
<b>Area gripper FSG-V with integrated valves</b> .....	<b>359</b>
<b>Area gripper FSG accessories</b> .....	<b>364</b>
<b>Bag grippers</b> .....	<b>367</b>
<b>FORMHAND</b> .....	<b>369</b>



### Area gripper CSG



#### Product notes

- > Compact, lightweight and energy-saving area gripper
- > Designed according to ISO TS 15066 for cobot applications
- > Low dead weight of only 1,360 g: Optimal use of the robot's load-bearing capacity
- > Energy-saving automatic for versions with internal vacuum generation reduces energy costs
- > Compact design
- > With intelligent electronic control of the internal vacuum source
- > Built-in display for setting and displaying process parameters
- > Version without compressed air to reduce maintenance and operating costs in compressed air-free production
- > A URcap plug in is available for Universal Robots cobots, plug ins for other cobots are available on request
- > For the safety of the application, the area gripper is protected against reverse polarity and fused to 1A (internal pump to 3A)

#### Technical data

Item no.	CSG.PG130.300.3F10C1	CSG.PG130.300.3F10P1	CSG.PG130.300.3F10T
Vacuum generation	Internal ejector	Internal pump	Connection to ext. pump
Number of suction cells	41	41	41
Working pressure [bar (psi)]	4 - 6 (58 - 87)	--	--
Air consumption [l/min]	108	--	--
Max. suction power [l/min]	140	40	--
Max. Final vacuum [%]	60	85	--
Power supply [V]	24 V DC	2x 24 V DC	24 V DC
Current consumption [A]	1A	1A + 2.5A	1A
Max. current consumption [°]	0.5A	0.5A + 2.5A	0.5A
Active suction area [mm <sup>2</sup> ]	8,750	8,750	8,750
Suction force at nominal power [N]	300	350	--
Weight [kg]	1.35	1.8	1.2
Accessories	Sealing foam: CSG.0002	Sealing foam: CSG.0002 Power supply unit for control cabinet installation: CSG.0017 Power supply with plug: CSG.0020	Sealing foam: CSG.0002

#### Application note

**CSG.PG130.300.3F10C1:** CSG with internal ejector  
 > suitable for **slightly porous and dense** materials

**CSG.PG130.300.3F10P1:** CSG with internal pump  
 > suitable for **dense** materials only

**CSG.PG130.300.3F10T:** CSG with connection to external pump  
 > suitable for **porous and dense** materials, depending on external pump





Application example



Suction capacity and evacuation time of the internal pump (CSG.PG130.300.3F10P1)

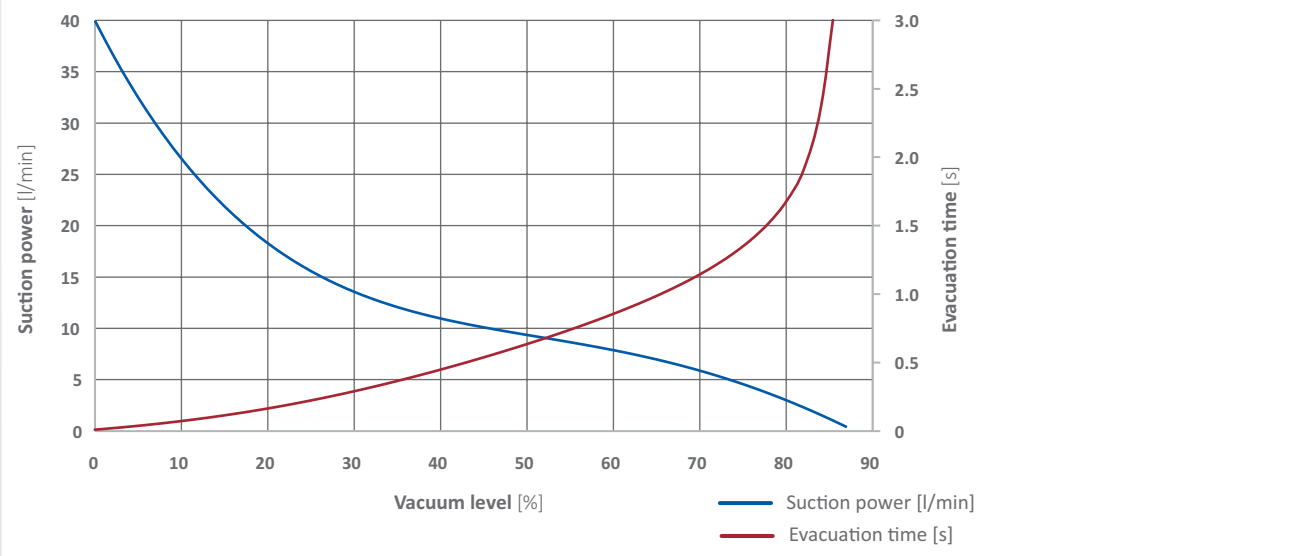



### Dimensions

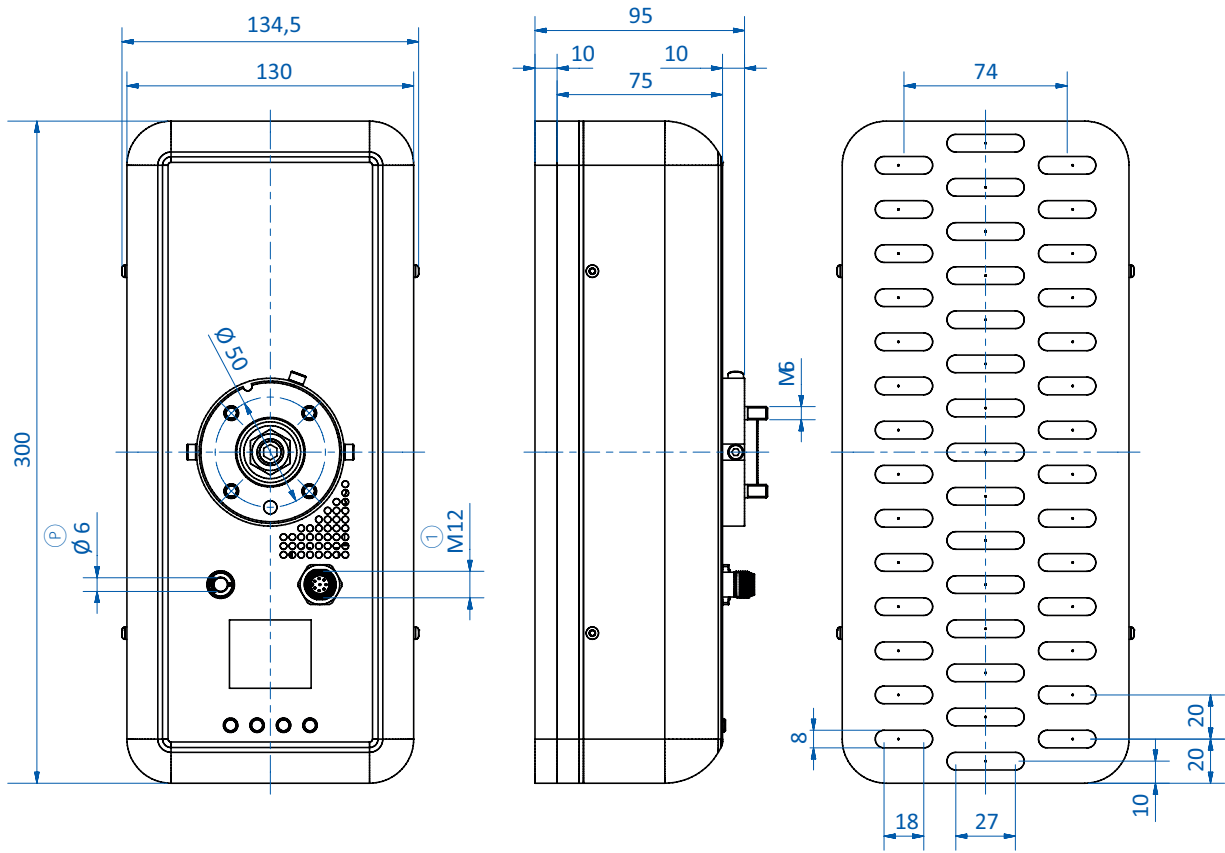

CSG.PG130.300.3F10C1

Ⓟ = Compressed air connection Ⓢ = Tubing nipple ① = 8-pin plug male for screwing ② = 2-pin plug male for screwing



Dimensions

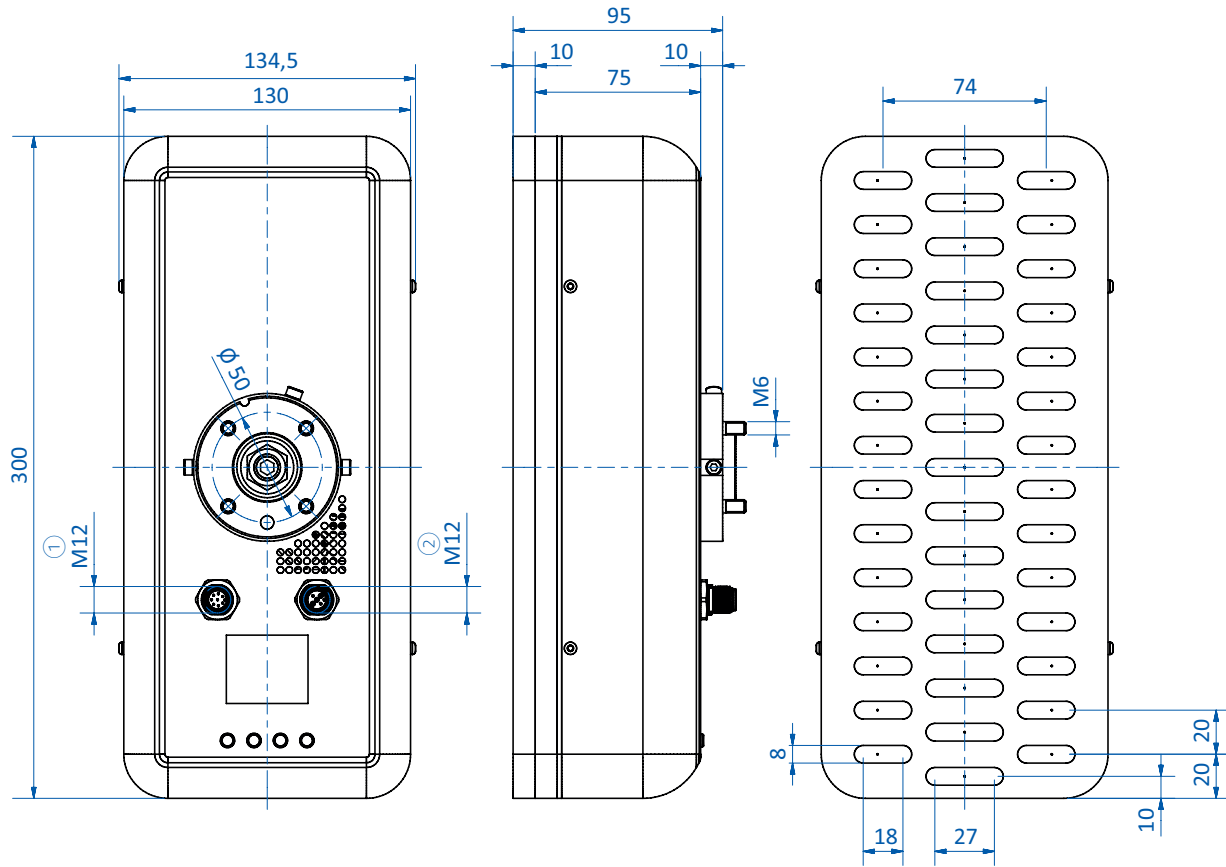

CSG.PG130.300.3F10P1

Ⓟ = Compressed air connection Ⓢ = Tubing nipple ① = 8-pin plug male for screwing ② = 2-pin plug male for screwing

Continued on the next page →



### Dimensions

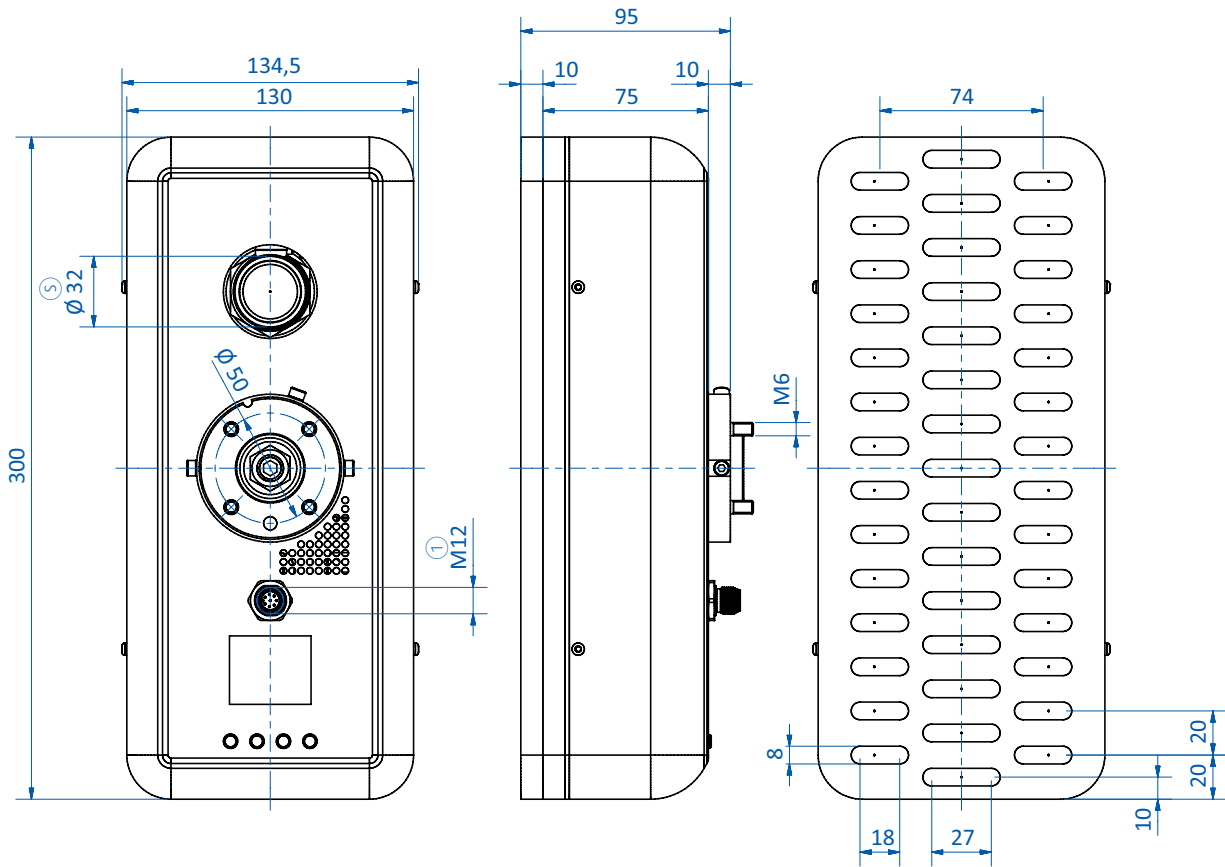

CSG.PG130.300.3F10T

Ⓟ = Compressed air connection   Ⓢ = Tubing nipple   ① = 8-pin plug male for screwing   ② = 2-pin plug male for screwing



### Area gripper with sealing foam



#### Product notes

- > For automated handling of individual products or product layers without changing grippers
- > Low noise emissions for a pleasant working environment
- > With built-in ejectors or with connection to a central vacuum supply
- > With check valves or flow reduction
- > The sealing foam can be replaced quickly, non-destructively and without residues
- > Area grippers with check valves are suitable for swivel/tilt movements up to less than 90°
- > Equipped with vacuum gauge 91.005 as standard
- > Other sealing foams (height, shape) on request

#### Technical data

Item no.	Valve type	Vacuum generation	Number of suction cells	Working pressure [bar (psi)]	Air consumption at 6 bar (87 psi) [Nl/min]	Suction power at 6 bar (87 psi) [Nl/min]	Nominal flow rate [Nl/min]	Suction force at nominal power [N]	Vacuum level [mbar (inHG)]	Weight [kg]	Dimensions		
											A [mm]	Ø G [mm]	H [mm]
<b>FSG.VG130.295.5F20C2</b>	Check valve	with integrated ejectors	53	4 - 6 (58 - 87)	200	700	--	426	-550 (-16.2)	2.6	295	--	--
<b>FSG.VG130.434.5F20C2</b>	Check valve	with integrated ejectors	83	4 - 6 (58 - 87)	200	700	--	688	-550 (-16.2)	3.3	434	--	--
<b>FSG.VG130.572.5F20C3</b>	Check valve	with integrated ejectors	113	4 - 6 (58 - 87)	300	1,050	--	909	-550 (-16.2)	3.8	572	--	--
<b>FSG.VG130.711.5F20C4</b>	Check valve	with integrated ejectors	143	4 - 6 (58 - 87)	400	1,400	--	1,150	-550 (-16.2)	4.5	711	--	--
<b>FSG.VG130.849.5F20C4</b>	Check valve	with integrated ejectors	173	4 - 6 (58 - 87)	400	1,400	--	1,391	-550 (-16.2)	5.2	849	--	--
<b>FSG.VG130.988.5F20C5</b>	Check valve	with integrated ejectors	203	4 - 6 (58 - 87)	500	1,750	--	1,633	-550 (-16.2)	5.6	988	--	--
<b>FSG.VG130.1126.5F20C6</b>	Check valve	with integrated ejectors	233	4 - 6 (58 - 87)	600	2,100	--	1,874	-550 (-16.2)	7	1,126	--	--
<b>FSG.VG130.1265.5F20C6</b>	Check valve	with integrated ejectors	263	4 - 6 (58 - 87)	600	2,100	--	2,115	-550 (-16.2)	7.4	1,265	--	--
<b>FSG.PG130.295.5F20C2</b>	Flow reduction	with integrated ejectors	53	4 - 6 (58 - 87)	200	700	--	426	-550 (-16.2)	2.6	295	--	--
<b>FSG.PG130.434.5F20C2</b>	Flow reduction	with integrated ejectors	83	4 - 6 (58 - 87)	200	700	--	688	-550 (-16.2)	3.3	434	--	--
<b>FSG.PG130.572.5F20C3</b>	Flow reduction	with integrated ejectors	113	4 - 6 (58 - 87)	300	1,050	--	909	-550 (-16.2)	3.8	572	--	--
<b>FSG.PG130.711.5F20C4</b>	Flow reduction	with integrated ejectors	143	4 - 6 (58 - 87)	400	1,400	--	1,150	-550 (-16.2)	4.5	711	--	--
<b>FSG.PG130.849.5F20C4</b>	Flow reduction	with integrated ejectors	173	4 - 6 (58 - 87)	400	1,400	--	1,391	-550 (-16.2)	5.2	849	--	--
<b>FSG.PG130.988.5F20C5</b>	Flow reduction	with integrated ejectors	203	4 - 6 (58 - 87)	500	1,750	--	1,633	-550 (-16.2)	5.6	988	--	--

Continued on the next page →



# Vacuum gripping systems | Area gripper FSG

Area gripper with sealing foam

Technical data											Dimensions		
Item no.	Valve type	Vacuum generation	Number of suction cells	Working pressure [bar (psi)]	Air consumption at 6 bar (87 psi) [Nl/min]	Suction power at 6 bar (87 psi) [Nl/min]	Nominal flow rate [Nl/min]	Suction force at nominal power [N]	Vacuum level [mbar (inHg)]	Weight [kg]	A [mm]	Ø G [mm]	H [mm]
<b>FSG.PG130.1126.5F20C6</b>	Flow reduction	with integrated ejectors	233	4 - 6 (58 - 87)	600	2,100	--	1,874	-550 (-16.2)	7	1,126	--	--
<b>FSG.PG130.1265.5F20C6</b>	Flow reduction	with integrated ejectors	263	4 - 6 (58 - 87)	600	2,100	--	2,115	-550 (-16.2)	7.4	1,265	--	--
<b>FSG.VG130.295.5F20T</b>	Check valve	central vacuum supply	53	--	--	--	150	320	-300 (-8.9)	2.3	295	32.5	54
<b>FSG.VG130.434.5F20T</b>	Check valve	central vacuum supply	83	--	--	--	300	501	-300 (-8.9)	3	434	32.5	54
<b>FSG.VG130.572.5F20T</b>	Check valve	central vacuum supply	113	--	--	--	400	682	-300 (-8.9)	3.5	572	32.5	54
<b>FSG.VG130.711.5F20T</b>	Check valve	central vacuum supply	143	--	--	--	510	863	-300 (-8.9)	4.2	711	60	49
<b>FSG.VG130.849.5F20T</b>	Check valve	central vacuum supply	173	--	--	--	600	1,044	-300 (-8.9)	4.9	849	60	49
<b>FSG.VG130.988.5F20T</b>	Check valve	central vacuum supply	203	--	--	--	750	1,224	-300 (-8.9)	5.1	988	60	49
<b>FSG.VG130.1126.5F20T</b>	Check valve	central vacuum supply	233	--	--	--	850	1,405	-300 (-8.9)	6.6	1,126	60	49
<b>FSG.VG130.1265.5F20T</b>	Check valve	central vacuum supply	263	--	--	--	950	1,586	-300 (-8.9)	7	1,265	60	49
<b>FSG.PG130.295.5F20T</b>	Flow reduction	central vacuum supply	53	--	--	--	150	320	-300 (-8.9)	2.3	295	32.5	54
<b>FSG.PG130.434.5F20T</b>	Flow reduction	central vacuum supply	83	--	--	--	300	501	-300 (-8.9)	3	434	32.5	54
<b>FSG.PG130.572.5F20T</b>	Flow reduction	central vacuum supply	113	--	--	--	400	682	-300 (-8.9)	3.5	572	32.5	54
<b>FSG.PG130.711.5F20T</b>	Flow reduction	central vacuum supply	143	--	--	--	510	863	-300 (-8.9)	4.2	711	60	49
<b>FSG.PG130.849.5F20T</b>	Flow reduction	central vacuum supply	173	--	--	--	600	1,044	-300 (-8.9)	4.9	849	60	49
<b>FSG.PG130.988.5F20T</b>	Flow reduction	central vacuum supply	203	--	--	--	750	1,224	-300 (-8.9)	5.1	988	60	49
<b>FSG.PG130.1126.5F20T</b>	Flow reduction	central vacuum supply	233	--	--	--	850	1,405	-300 (-8.9)	6.6	1,126	60	49
<b>FSG.PG130.1265.5F20T</b>	Flow reduction	central vacuum supply	263	--	--	--	950	1,586	-300 (-8.9)	7	1,265	60	49

## Hinweis

Die Saugkraft ist abhängig vom anzusaugenden Werkstück und der Vakuumerzeugung.  
 Für Typen mit integrierten Ejektoren kann der angegebene Vakuumgrad nur bei nichtdurchsaugenden Werkstücken erreicht werden.  
 Bei Typen mit externer Vakuumversorgung sind die Vakuumquelle und der Abstand zur Vakuumquelle für den Vakuumgrad und damit die Saugkraft entscheidend. Der angegebene Vakuumgrad und die angegebene Saugkraft dienen hier nur als beispielhaft Orientierung.  
 Durch den Einsatz verschiedener Vakuumerzeuger sind sowohl höhere, als auch niedrigere Vakuumgrade/Saugkräfte möglich.



## Optional accessories and spare parts

### Optional accessories:

- > Electronic vacuum switch with display GS02.001
- > Electronic vacuum switch GS02.003
- > Electronic vacuum and pressure switch 20.026
- > Flange module for area gripper FSG.ACC130.0001
- > Slot nut 1x M8 for area gripper FSG.ACC130.0002
- > Optical sensor with sensor holder FSG.ACC130.0004

### Spare parts:

- > Spare foam length 295 mm FSG.ACC130.295.5F20
- > Spare foam length 434 mm FSG.ACC130.434.5F20
- > Spare foam length 572 mm FSG.ACC130.572.5F20
- > Spare foam length 711 mm FSG.ACC130.711.5F20
- > Spare foam length 849 mm FSG.ACC130.849.5F20
- > Spare foam length 988 mm FSG.ACC130.988.5F20
- > Spare foam length 1126 mm FSG.ACC130.1126.5F20
- > Spare foam length 1265 mm FSG.ACC130.1265.5F20
- > Ejector for area gripper FSG.ACC130.0003

## Dimensions

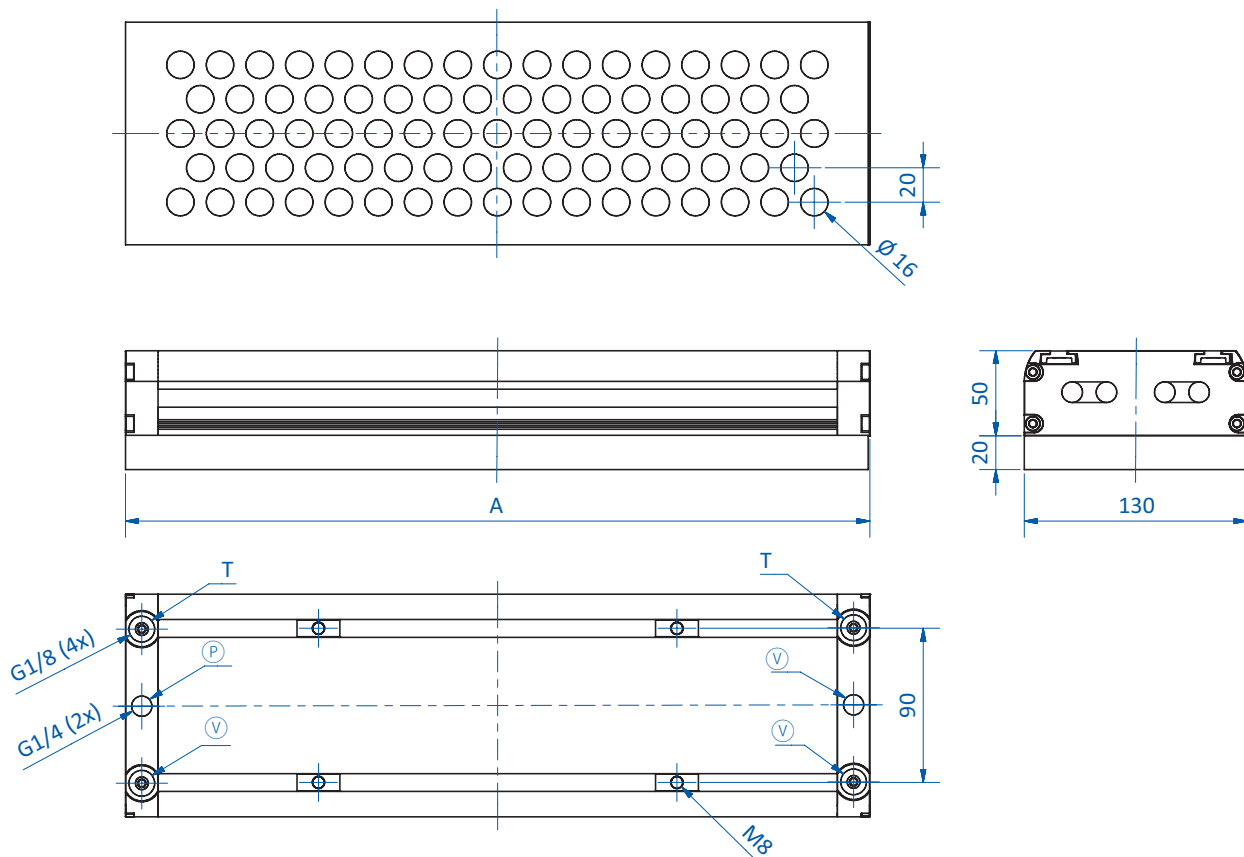

Vacuum generation with integrated ejectors

Ⓟ = Compressed air connection    Ⓥ = Vacuum connection    \* = Transfer line

Continued on the next page →



# Vacuum gripping systems | Area gripper FSG

Area gripper with sealing foam

## Dimensions

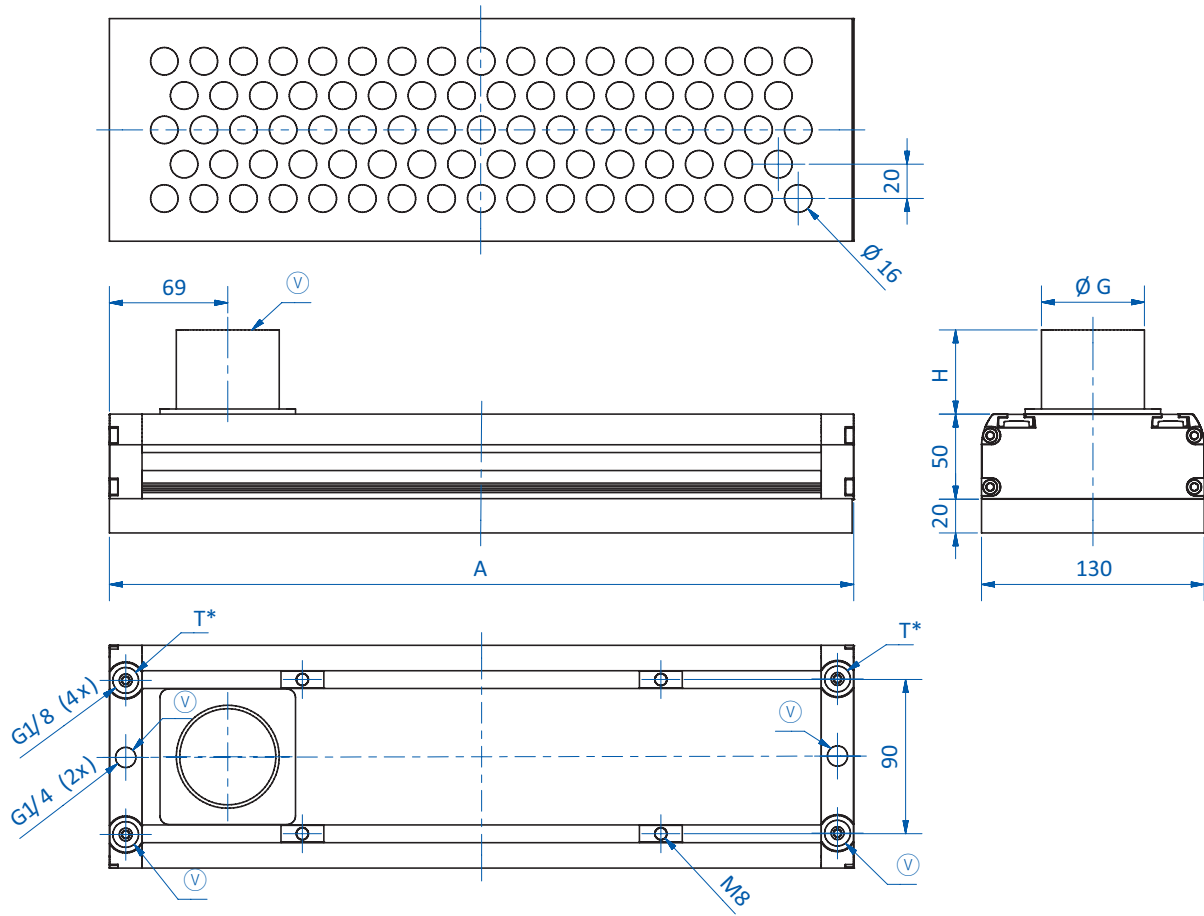

Vacuum generation via central vacuum supply

Ⓟ = Compressed air connection    Ⓜ = Vacuum connection    \* = Transfer line





### Area gripper with plug-in vacuum cups diameter 20 mm



#### Product notes

- > For automated handling of individual products or product layers without changing grippers
- > Low noise emissions for a pleasant working environment
- > With built-in ejectors or with connection to central vacuum supply
- > With check valves or flow reduction
- > Plug-in cups can be changed easily and quickly
- > Area grippers with check valves are suitable for swivel/tilt movements up to less than 90°
- > Equipped with vacuum gauge 91.005 as standard

#### Technical data

Item no.	Valve type	Vacuum generation	Number of vacuum cups	Working pressure [bar (psi)]	Air consumption at 6 bar (87 psi) [Nl/min]	Suction power at 6 bar (87 psi) [N/min]	Nominal flow rate [Nl/min]	Suction force at nominal power [N]	Vacuum level [mbar (inHg)]	Weight [kg]	Dimensions		
											A [mm]	Ø G [mm]	H [mm]
FSG.VG130.295.5C02C2	Check valve	with integrated ejectors	53	4 - 6 (58 - 87)	200	700	--	253	-550 (-16.2)	3	295	--	--
FSG.VG130.434.5C02C2	Check valve	with integrated ejectors	83	4 - 6 (58 - 87)	200	700	--	396	-550 (-16.2)	3.8	434	--	--
FSG.VG130.572.5C02C3	Check valve	with integrated ejectors	113	4 - 6 (58 - 87)	300	1,050	--	539	-550 (-16.2)	4.5	572	--	--
FSG.VG130.711.5C02C4	Check valve	with integrated ejectors	143	4 - 6 (58 - 87)	400	1,400	--	682	-550 (-16.2)	5.3	711	--	--
FSG.VG130.849.5C02C4	Check valve	with integrated ejectors	173	4 - 6 (58 - 87)	400	1,400	--	825	-550 (-16.2)	6.2	849	--	--
FSG.VG130.988.5C02C5	Check valve	with integrated ejectors	203	4 - 6 (58 - 87)	500	1,750	--	968	-550 (-16.2)	7.2	988	--	--
FSG.VG130.1126.5C02C6	Check valve	with integrated ejectors	233	4 - 6 (58 - 87)	600	2,100	--	1,111	-550 (-16.2)	8.1	1,126	--	--
FSG.VG130.1265.5C02C6	Check valve	with integrated ejectors	263	4 - 6 (58 - 87)	600	2,100	--	1,254	-550 (-16.2)	8.9	1,265	--	--
FSG.PG130.295.5C02C2	Flow reduction	with integrated ejectors	53	4 - 6 (58 - 87)	200	700	--	253	-550 (-16.2)	3	295	--	--
FSG.PG130.434.5C02C2	Flow reduction	with integrated ejectors	83	4 - 6 (58 - 87)	200	700	--	396	-550 (-16.2)	3.8	434	--	--
FSG.PG130.572.5C02C3	Flow reduction	with integrated ejectors	113	4 - 6 (58 - 87)	300	1,050	--	539	-550 (-16.2)	4.5	572	--	--
FSG.PG130.711.5C02C4	Flow reduction	with integrated ejectors	143	4 - 6 (58 - 87)	400	1,400	--	682	-550 (-16.2)	5.3	711	--	--
FSG.PG130.849.5C02C4	Flow reduction	with integrated ejectors	173	4 - 6 (58 - 87)	400	1,400	--	825	-550 (-16.2)	6.2	849	--	--
FSG.PG130.988.5C02C5	Flow reduction	with integrated ejectors	203	4 - 6 (58 - 87)	500	1,750	--	968	-550 (-16.2)	7.2	988	--	--

Continued on the next page →



# Vacuum gripping systems | Area gripper FSG

Area gripper with plug-in vacuum cups diameter 20 mm

Technical data											Dimensions		
Item no.	Valve type	Vacuum generation	Number of vacuum cups	Working pressure [bar (psi)]	Air consumption at 6 bar (87 psi) [Nl/min]	Suction power at 6 bar (87 psi) [Nl/min]	Nominal flow rate [Nl/min]	Suction force at nominal power [N]	Vacuum level [mbar (inHg)]	Weight [kg]	A [mm]	Ø G [mm]	H [mm]
<b>FSG.PG130.1126.5C02C6</b>	Flow reduction	with integrated ejectors	233	4 - 6 (58 - 87)	600	2,100	--	1,111	-550 (-16.2)	8.1	1,126	--	--
<b>FSG.PG130.1265.5C02C6</b>	Flow reduction	with integrated ejectors	263	4 - 6 (58 - 87)	600	2,100	--	1,254	-550 (-16.2)	8.9	1,265	--	--
<b>FSG.VG130.295.5C02T</b>	Check valve	central vacuum supply	53	--	--	--	150	138	-300 (-8.9)	2.8	295	32.5	54
<b>FSG.VG130.434.5C02T</b>	Check valve	central vacuum supply	83	--	--	--	300	216	-300 (-8.9)	3.8	434	32.5	54
<b>FSG.VG130.572.5C02T</b>	Check valve	central vacuum supply	113	--	--	--	400	294	-300 (-8.9)	4.3	572	32.5	54
<b>FSG.VG130.711.5C02T</b>	Check valve	central vacuum supply	143	--	--	--	510	372	-300 (-8.9)	5.1	711	60	49
<b>FSG.VG130.849.5C02T</b>	Check valve	central vacuum supply	173	--	--	--	600	450	-300 (-8.9)	6	849	60	49
<b>FSG.VG130.988.5C02T</b>	Check valve	central vacuum supply	203	--	--	--	750	528	-300 (-8.9)	7	988	60	49
<b>FSG.VG130.1126.5C02T</b>	Check valve	central vacuum supply	233	--	--	--	850	606	-300 (-8.9)	7.7	1,126	60	49
<b>FSG.VG130.1265.5C02T</b>	Check valve	central vacuum supply	263	--	--	--	950	684	-300 (-8.9)	8.5	1,265	60	49
<b>FSG.PG130.295.5C02T</b>	Flow reduction	central vacuum supply	53	--	--	--	150	138	-300 (-8.9)	2.8	295	32.5	54
<b>FSG.PG130.434.5C02T</b>	Flow reduction	central vacuum supply	83	--	--	--	300	216	-300 (-8.9)	3.8	434	32.5	54
<b>FSG.PG130.572.5C02T</b>	Flow reduction	central vacuum supply	113	--	--	--	400	294	-300 (-8.9)	4.3	572	32.5	54
<b>FSG.PG130.711.5C02T</b>	Flow reduction	central vacuum supply	143	--	--	--	510	372	-300 (-8.9)	5.1	711	60	49
<b>FSG.PG130.849.5C02T</b>	Flow reduction	central vacuum supply	173	--	--	--	600	450	-300 (-8.9)	6	849	60	49
<b>FSG.PG130.988.5C02T</b>	Flow reduction	central vacuum supply	203	--	--	--	750	528	-300 (-8.9)	7	988	60	49
<b>FSG.PG130.1126.5C02T</b>	Flow reduction	central vacuum supply	233	--	--	--	850	606	-300 (-8.9)	7.7	1,126	60	49
<b>FSG.PG130.1265.5C02T</b>	Flow reduction	central vacuum supply	263	--	--	--	950	684	-300 (-8.9)	8.5	1,265	60	49

## Notes

The suction force depends on the workpiece to be suctioned and the vacuum generation.  
 For types with integrated ejectors, the specified vacuum level can only be achieved with non-suctioning workpieces.  
 For types with external vacuum supply, the vacuum source and the distance to the vacuum source are decisive for the vacuum level and thus the suction force. The specified vacuum level and the specified suction force serve here only as an exemplary orientation.  
 By using different vacuum generators, both higher and lower vacuum levels/suction forces are possible.



## Optional accessories and spare parts

### Optional accessories:

- > Electronic vacuum switch with display GS02.001
- > Electronic vacuum switch GS02.003
- > Electronic vacuum and pressure switch 20.026
- > Flange module for area gripper FSG.ACC130.0001
- > Slot nut 1x M8 for area gripper FSG.ACC130.0002
- > Optical sensor with sensor holder FSG.ACC130.000

### Spare parts:

- > Replacement plug-in cup in silicone 55° Shore A 21.020.185.2
- > Ejector for area gripper FSG.ACC130.0003

## Dimensions

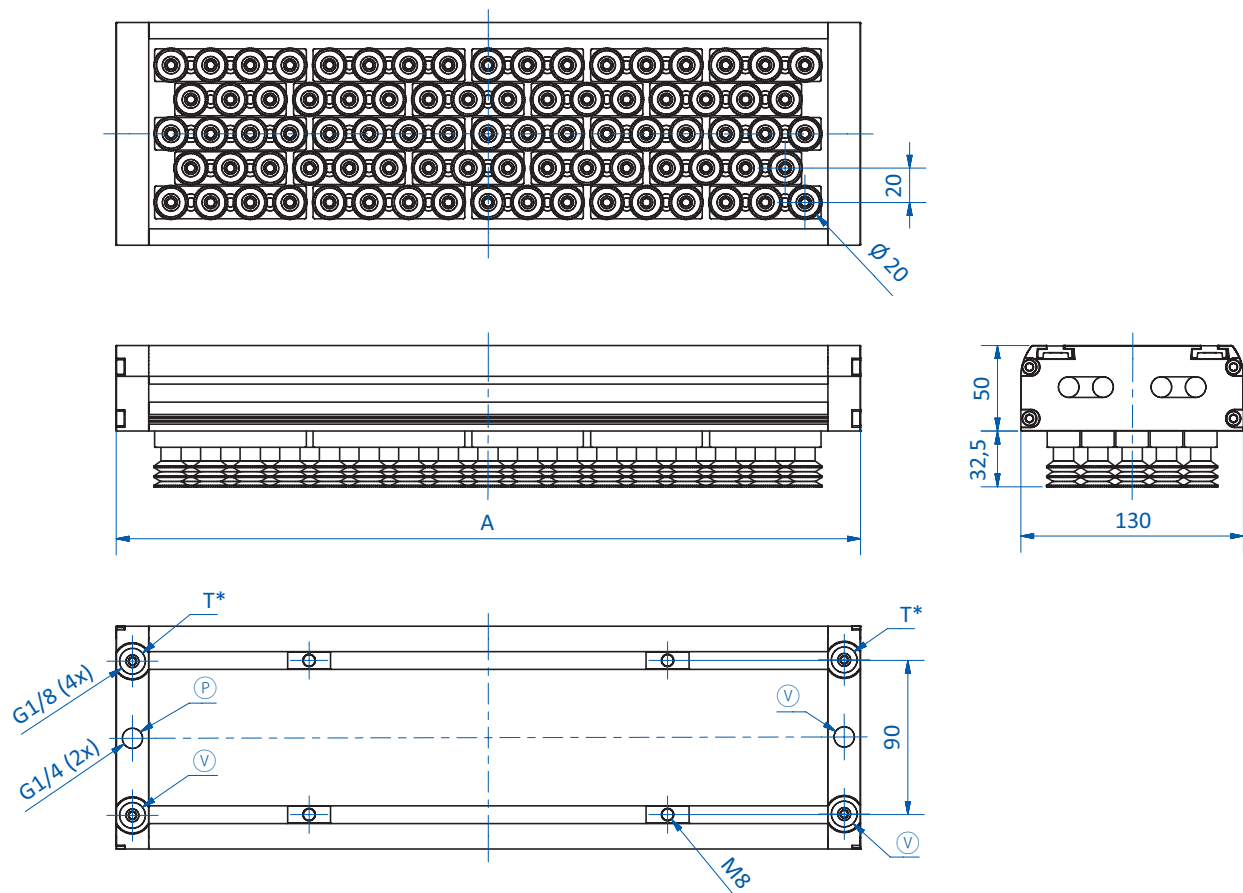

Vacuum generation with integrated ejectors

Ⓟ = Compressed air connection   Ⓥ = Vacuum connection   \* = Transfer line

Continued on the next page →



# Vacuum gripping systems | Area gripper FSG

Area gripper with plug-in vacuum cups diameter 20 mm

## Dimensions

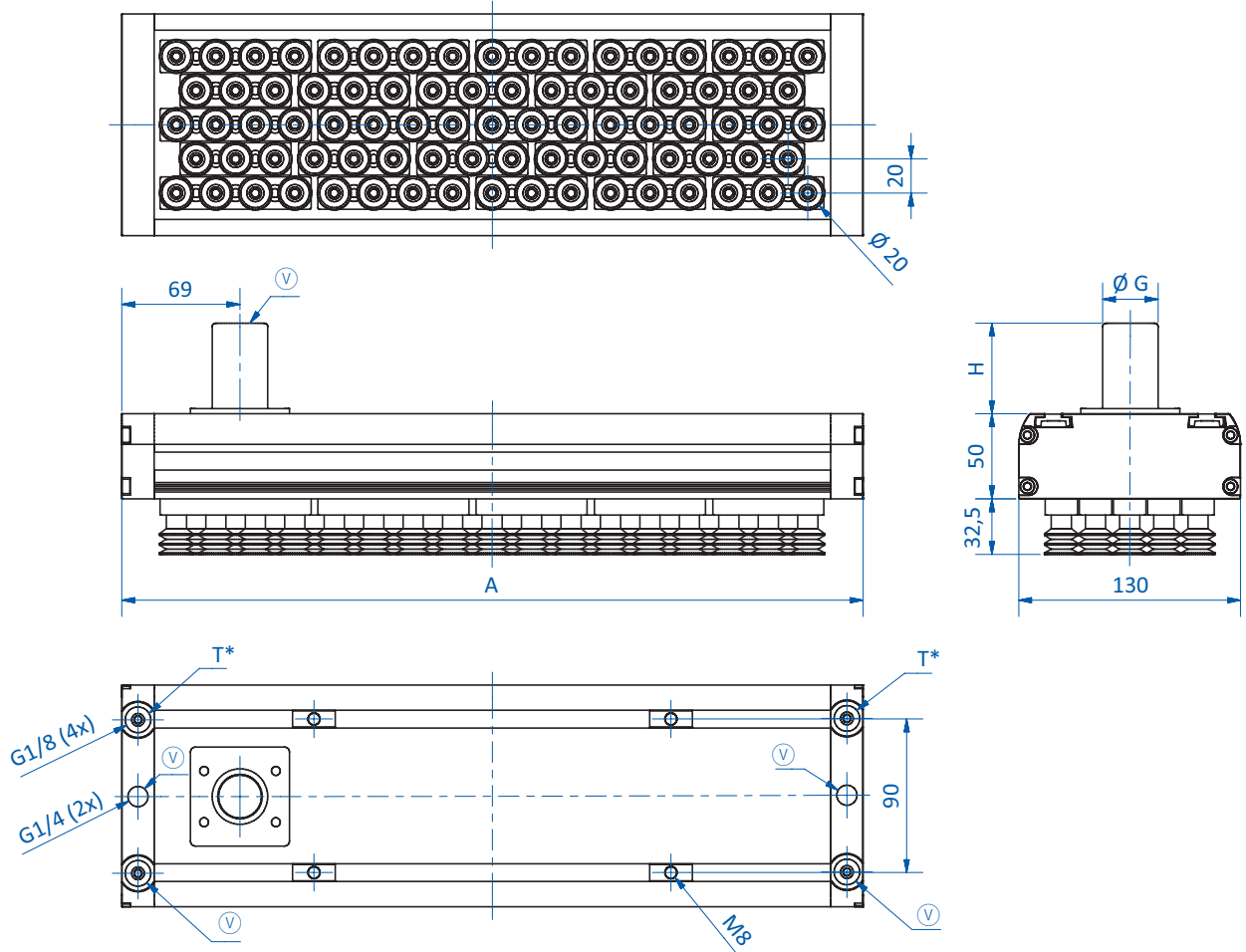

Vacuum generation via central vacuum supply

ⓐ = Compressed air connection ⓪ = Vacuum connection \* = Transfer line



Area gripper with plug-in vacuum cups diameter 40 mm



### Product notes

- > For automated handling of individual products or product layers without changing grippers
- > Low noise emissions for a pleasant working environment
- > With built-in ejectors or with connection to a central vacuum supply
- > With check valves or flow reduction
- > The plug-in vacuum cups can be exchanged easily and quickly
- > Area grippers with check valves are suitable for swivel/tilt movements up to less than 90°
- > Equipped with vacuum gauge 91.005 as standard

### Technical data

Item no.	Valve type	Vacuum generation	Number of vacuum cups	Working pressure [bar (psi)]	Air consumption at 6 bar (87 psi) [NI/min]	Suction power at 6 bar (87 psi) [NI/min]	Nominal flow rate [NI/min]	Suction force at nominal power [N]	Vacuum level [mbar (inHg)]	Weight [kg]	Dimensions		
											A [mm]	Ø G [mm]	H [mm]
<b>FSG.VG130.295.3C02C2</b>	Check valve	with integrated ejectors	17	4 - 6 (58 - 87)	200	700	--	169	-550 (-16.2)	3	295	--	--
<b>FSG.VG130.434.3C02C2</b>	Check valve	with integrated ejectors	26	4 - 6 (58 - 87)	200	700	--	258	-550 (-16.2)	3.8	434	--	--
<b>FSG.VG130.572.3C02C3</b>	Check valve	with integrated ejectors	35	4 - 6 (58 - 87)	300	1,050	--	348	-550 (-16.2)	4.5	572	--	--
<b>FSG.VG130.711.3C02C4</b>	Check valve	with integrated ejectors	44	4 - 6 (58 - 87)	400	1,400	--	437	-550 (-16.2)	5.3	711	--	--
<b>FSG.VG130.849.3C02C4</b>	Check valve	with integrated ejectors	53	4 - 6 (58 - 87)	400	1,400	--	526	-550 (-16.2)	6.2	849	--	--
<b>FSG.VG130.988.3C02C5</b>	Check valve	with integrated ejectors	62	4 - 6 (58 - 87)	500	1,750	--	616	-550 (-16.2)	7.2	988	--	--
<b>FSG.VG130.1126.3C02C6</b>	Check valve	with integrated ejectors	71	4 - 6 (58 - 87)	600	2,100	--	705	-550 (-16.2)	8.1	1,126	--	--
<b>FSG.VG130.1265.3C02C6</b>	Check valve	with integrated ejectors	80	4 - 6 (58 - 87)	600	2,100	--	795	-550 (-16.2)	8.9	1,265	--	--
<b>FSG.PG130.295.3C02C2</b>	Flow reduction	with integrated ejectors	17	4 - 6 (58 - 87)	200	700	--	169	-550 (-16.2)	3	295	--	--
<b>FSG.PG130.434.3C02C2</b>	Flow reduction	with integrated ejectors	26	4 - 6 (58 - 87)	200	700	--	258	-550 (-16.2)	3.8	434	--	--
<b>FSG.PG130.572.3C02C3</b>	Flow reduction	with integrated ejectors	35	4 - 6 (58 - 87)	300	1,050	--	348	-550 (-16.2)	4.5	572	--	--
<b>FSG.PG130.711.3C02C4</b>	Flow reduction	with integrated ejectors	44	4 - 6 (58 - 87)	400	1,400	--	437	-550 (-16.2)	5.3	711	--	--
<b>FSG.PG130.849.3C02C4</b>	Flow reduction	with integrated ejectors	53	4 - 6 (58 - 87)	400	1,400	--	526	-550 (-16.2)	6.2	849	--	--
<b>FSG.PG130.988.3C02C5</b>	Flow reduction	with integrated ejectors	62	4 - 6 (58 - 87)	500	1,750	--	616	-550 (-16.2)	7.2	988	--	--

Continued on the next page →



# Vacuum gripping systems | Area gripper FSG

Area gripper with plug-in vacuum cups diameter 40 mm

Technical data											Dimensions		
Item no.	Valve type	Vacuum generation	Number of vacuum cups	Working pressure [bar (psi)]	Air consumption at 6 bar (87 psi) [Nl/min]	Suction power at 6 bar (87 psi) [Nl/min]	Nominal flow rate [Nl/min]	Suction force at nominal power [N]	Vacuum level [mbar (inHg)]	Weight [kg]	A [mm]	Ø G [mm]	H [mm]
<b>FSG.PG130.1126.3C02C6</b>	Flow reduction	with integrated ejectors	71	4 - 6 (58 - 87)	600	2,100	--	705	-550 (-16.2)	8.1	1,126	--	--
<b>FSG.PG130.1265.3C02C6</b>	Flow reduction	with integrated ejectors	80	4 - 6 (58 - 87)	600	2,100	--	795	-550 (-16.2)	8.9	1,265	--	--
<b>FSG.VG130.295.3C02T</b>	Check valve	central vacuum supply	17	--	--	--	150	127	-300 (-8.9)	2.8	295	32.5	54
<b>FSG.VG130.434.3C02T</b>	Check valve	central vacuum supply	26	--	--	--	300	194	-300 (-8.9)	3.8	434	32.5	54
<b>FSG.VG130.572.3C02T</b>	Check valve	central vacuum supply	35	--	--	--	400	261	-300 (-8.9)	4.3	572	32.5	54
<b>FSG.VG130.711.3C02T</b>	Check valve	central vacuum supply	44	--	--	--	510	328	-300 (-8.9)	5.1	711	60	49
<b>FSG.VG130.849.3C02T</b>	Check valve	central vacuum supply	53	--	--	--	600	395	-300 (-8.9)	6	849	60	49
<b>FSG.VG130.988.3C02T</b>	Check valve	central vacuum supply	62	--	--	--	750	462	-300 (-8.9)	7	988	60	49
<b>FSG.VG130.1126.3C02T</b>	Check valve	central vacuum supply	71	--	--	--	850	529	-300 (-8.9)	7.7	1,126	60	49
<b>FSG.VG130.1265.3C02T</b>	Check valve	central vacuum supply	80	--	--	--	950	596	-300 (-8.9)	8.5	1,265	60	49
<b>FSG.PG130.295.3C02T</b>	Flow reduction	central vacuum supply	17	--	--	--	150	127	-300 (-8.9)	2.8	295	32.5	54
<b>FSG.PG130.434.3C02T</b>	Flow reduction	central vacuum supply	26	--	--	--	300	194	-300 (-8.9)	3.8	434	32.5	54
<b>FSG.PG130.572.3C02T</b>	Flow reduction	central vacuum supply	35	--	--	--	400	261	-300 (-8.9)	4.3	572	32.5	54
<b>FSG.PG130.711.3C02T</b>	Flow reduction	central vacuum supply	44	--	--	--	510	328	-300 (-8.9)	5.1	711	60	49
<b>FSG.PG130.849.3C02T</b>	Flow reduction	central vacuum supply	53	--	--	--	600	395	-300 (-8.9)	6	849	60	49
<b>FSG.PG130.988.3C02T</b>	Flow reduction	central vacuum supply	62	--	--	--	750	462	-300 (-8.9)	7	988	60	49
<b>FSG.PG130.1126.3C02T</b>	Flow reduction	central vacuum supply	71	--	--	--	850	529	-300 (-8.9)	7.7	1,126	60	49
<b>FSG.PG130.1265.3C02T</b>	Flow reduction	central vacuum supply	80	--	--	--	950	596	-300 (-8.9)	8.5	1,265	60	49

## Notes

The suction force depends on the workpiece to be suctioned and the vacuum generation.  
 For types with integrated ejectors, the specified vacuum level can only be achieved with non-suctioning workpieces.  
 For types with external vacuum supply, the vacuum source and the distance to the vacuum source are decisive for the vacuum level and thus the suction force. The specified vacuum level and the specified suction force serve here only as an exemplary orientation.  
 By using different vacuum generators, both higher and lower vacuum levels/suction forces are possible.



### Optional accessories and spare parts

Optional accessories:

- > Electronic vacuum switch with display GS02.001
- > Electronic vacuum switch GS02.003
- > Electronic vacuum and pressure switch 20.026
- > Flange module for area gripper FSG.ACC130.0001
- > Slot nut 1x M8 for area gripper FSG.ACC130.0002
- > Optical sensor with sensor holder FSG.ACC130.0004

Spare parts:

- > Replacement plug-in cup in silicone 55° Shore A 21.040.186.2
- > Ejector for area gripper FSG.ACC130.0003

### Dimensions

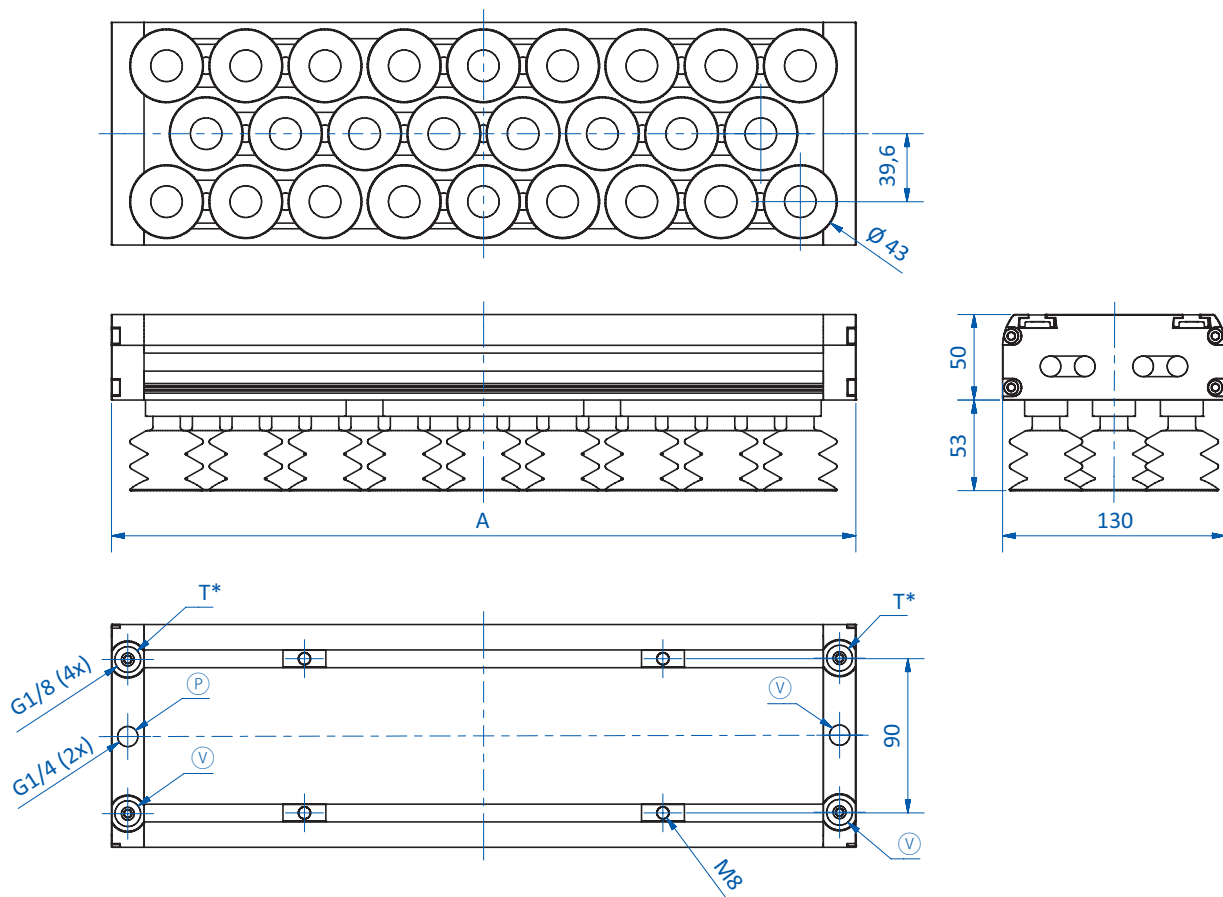

Vacuum generation with integrated ejectors

Ⓟ = Compressed air connection    Ⓥ = Vacuum connection    \* = Transfer line

Continued on the next page →



# Vacuum gripping systems | Area gripper FSG

Area gripper with plug-in vacuum cups diameter 40 mm

## Dimensions

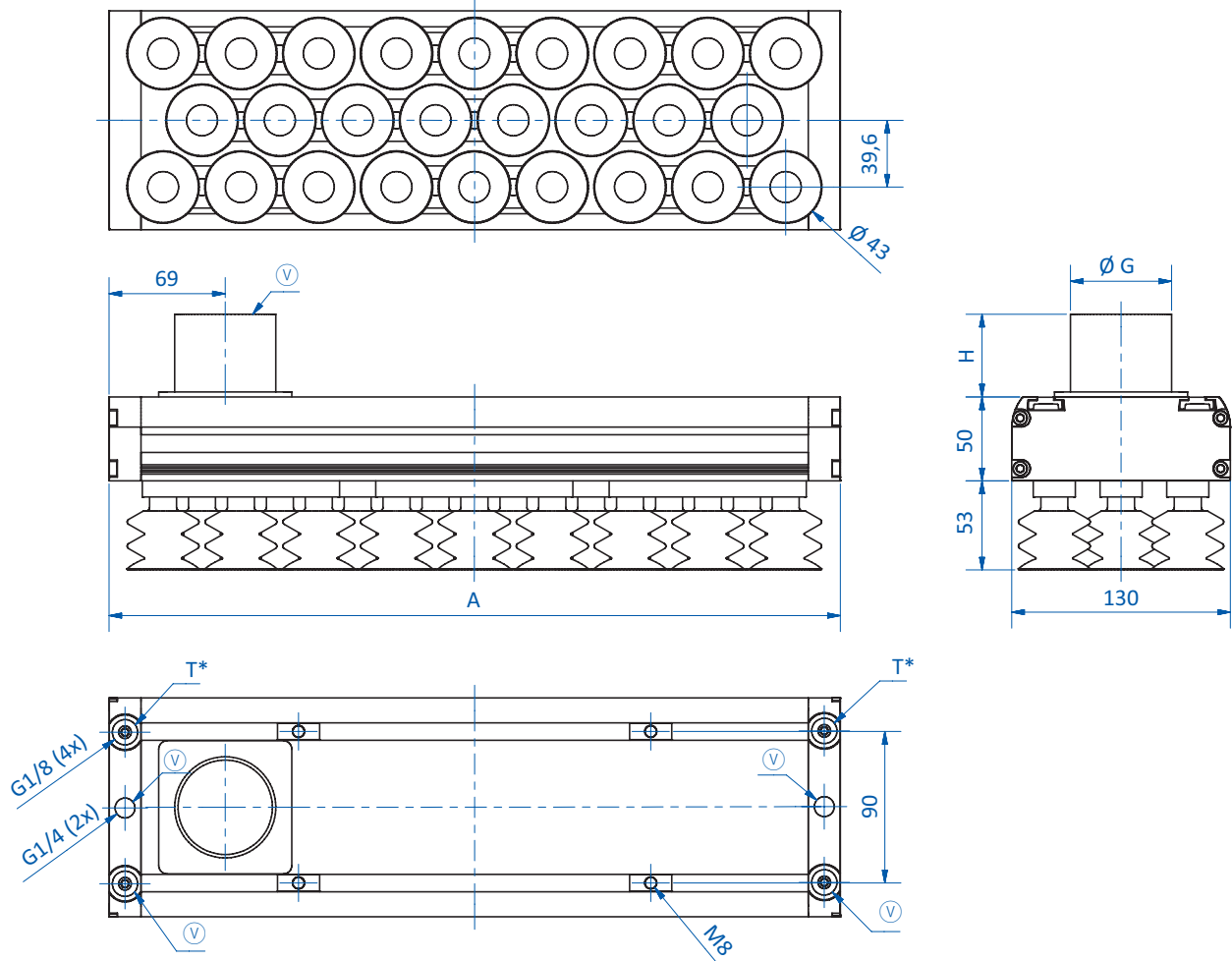

Vacuum generation via central vacuum supply

Ⓟ = Compressed air connection    Ⓥ = Vacuum connection    \* = Transfer line





### Area gripper FSG-V with integrated valves



#### Product notes

- > For automated handling of individual products or product layers without changing grippers
- > Low noise emissions for a pleasant working environment
- > With built-in cartridge ejectors
- > With integrated valves to control the suction (NO) and blow-off (NC) functions
- > With check valves or flow reduction
- > The sealing foam can be replaced quickly, non-destructively and without leaving residues

#### Technical data

Item no.	Valve type	Length [mm]	Number of suction cells	Working pressure [bar (psi)]	Air consumption at 6 bar (87 psi) [l/min]	Suction power at 6 bar (87 psi) [W/min]	Suction force at nominal power [N]	Vacuum level [mbar (inHg)]	Power supply [V]	Current consumption at 24 VDC max [mA]	Electric connection	Weight [kg]
<b>FSG-V.VG130.434.5F20C2</b>	Check valve	434	83	4 - 6 (58 - 87)	200	700	668	-550 (-16.2)	24	46	1x Plug M8x1; 4-pin	3.8
<b>FSG-V.VG130.572.5F20C3</b>	Check valve	572	113	4 - 6 (58 - 87)	300	1,050	909	-550 (-16.2)	24	46	1x Plug M8x1; 4-pin	4.3
<b>FSG-V.VG130.711.5F20C4</b>	Check valve	711	143	4 - 6 (58 - 87)	400	1,400	1,150	-550 (-16.2)	24	46	1x Plug M8x1; 4-pin	5
<b>FSG-V.VG130.849.5F20C4</b>	Check valve	849	173	4 - 6 (58 - 87)	400	1,400	1,391	-550 (-16.2)	24	46	1x Plug M8x1; 4-pin	5.7
<b>FSG-V.VG130.988.5F20C5</b>	Check valve	988	203	4 - 6 (58 - 87)	500	1,750	1,633	-550 (-16.2)	24	92	2x Plug M8x1; 4-pin	6.1
<b>FSG-V.VG130.1126.5F20C6</b>	Check valve	1,126	233	4 - 6 (58 - 87)	600	2,100	1,874	-550 (-16.2)	24	92	2x Plug M8x1; 4-pin	7.5
<b>FSG-V.VG130.1265.5F20C6</b>	Check valve	1,265	263	4 - 6 (58 - 87)	600	2,100	2,115	-550 (-16.2)	24	92	2x Plug M8x1; 4-pin	7.9
<b>FSG-V.PG130.434.5F20C2</b>	Flow reduction	434	83	4 - 6 (58 - 87)	200	700	668	-550 (-16.2)	24	92	1x Plug M8x1; 4-pin	3.8
<b>FSG-V.PG130.572.5F20C3</b>	Flow reduction	575	113	4 - 6 (58 - 87)	300	1,050	909	-550 (-16.2)	24	46	1x Plug M8x1; 4-pin	4.3
<b>FSG-V.PG130.711.5F20C4</b>	Flow reduction	711	143	4 - 6 (58 - 87)	400	1,400	1,150	-550 (-16.2)	24	46	1x Plug M8x1; 4-pin	5
<b>FSG-V.PG130.849.5F20C4</b>	Flow reduction	849	173	4 - 6 (58 - 87)	400	1,400	1,391	-550 (-16.2)	24	46	1x Plug M8x1; 4-pin	5.7
<b>FSG-V.PG130.988.5F20C5</b>	Flow reduction	988	203	4 - 6 (58 - 87)	500	1,750	1,633	-550 (-16.2)	24	92	2x Plug M8x1; 4-pin	6.1
<b>FSG-V.PG130.1126.5F20C6</b>	Flow reduction	1,126	233	4 - 6 (58 - 87)	600	2,100	1,874	-550 (-16.2)	24	92	2x Plug M8x1; 4-pin	7.5
<b>FSG-V.PG130.1265.5F20C6</b>	Flow reduction	1,265	263	4 - 6 (58 - 87)	600	2,100	2,115	-550 (-16.2)	24	92	2x Plug M8x1; 4-pin	7.9

Continued on the next page →



# Vacuum gripping systems | Area gripper FSG

## Area gripper FSG-V with integrated valves

### Notes

- > Area grippers with check valves are suitable for swivel/tilt movements up to less than 90°
- > Equipped with pressure gauge as standard, vacuum switch optionally available
- > Other sealing foams (height, shape) on request

### Optional accessories and spare parts

#### Optional accessories:

- > Electronic vacuum switch with display GS02.001
- > Electronic vacuum switch GS02.003
- > Electronic vacuum and pressure switch 20.026
- > Flange module for large-area gripper FSG.ACC130.0001
- > Slot nut 1x M8 for large-area gripper FSG.ACC130.0002
- > Optical sensor with sensor holder FSG.ACC130.0004

#### Spare parts:

- > Spare foam length 295 mm FSG.ACC130.295.5F20
- > Spare foam length 434 mm FSG.ACC130.434.5F20
- > Spare foam length 572 mm FSG.ACC130.572.5F20
- > Spare foam length 711 mm FSG.ACC130.711.5F20
- > Spare foam length 849 mm FSG.ACC130.849.5F20
- > Spare foam length 988 mm FSG.ACC130.988.5F20
- > Spare foam length 1126 mm FSG.ACC130.1126.5F20
- > Spare foam length 1265 mm FSG.ACC130.1265.5F20

### Dimensions

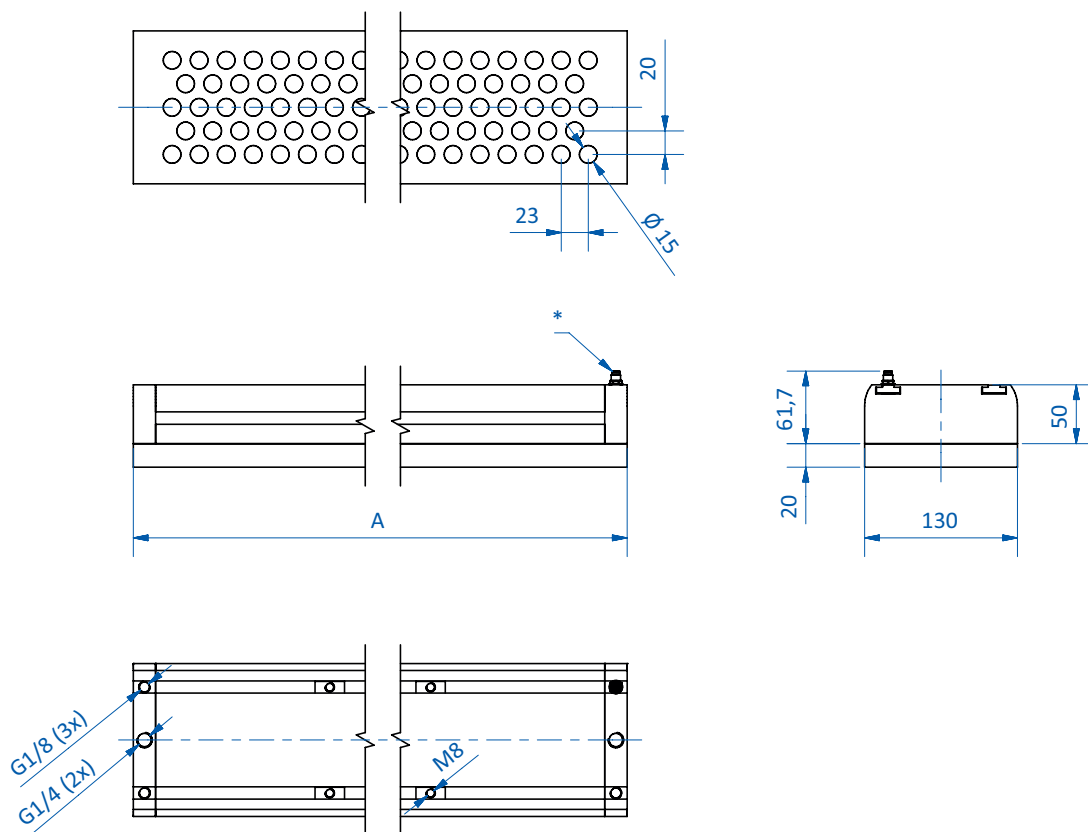

FSG-V.VG130.434.5F20C2 | FSG-V.VG130.572.5F20C3 | FSG-V.VG130.711.5F20C4 | FSG-V.VG130.849.5F20C4 |  
 FSG-V.PG130.434.5F20C2 | FSG-V.PG130.572.5F20C3 | FSG-V.PG130.711.5F20C4 | FSG-V.PG130.849.5F20C4

\* = Control connection 4-pole M8x1



### Dimensions

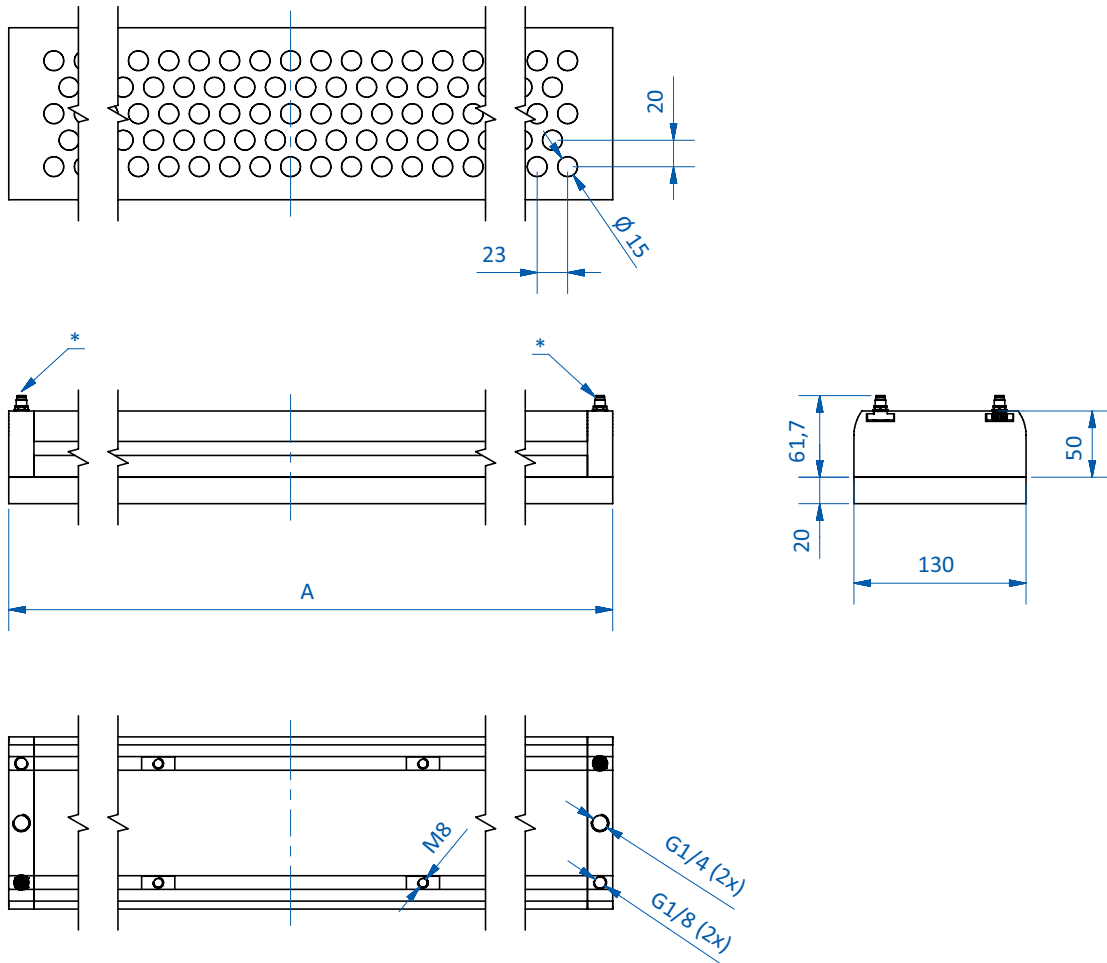

FSG-V.VG130.988.5F20C5 | FSG-V.VG130.1126.5F20C6 | FSG-V.VG130.1265.5F20C6 |  
 FSG-V.PG130.988.5F20C5 | FSG-V.PG130.1126.5F20C6 | FSG-V.PG130.1265.5F20C6

\* = Control connection 4-pole M8x1

Item no.	A [mm]
FSG-V.VG130.434.5F20C2	434
FSG-V.VG130.572.5F20C3	572
FSG-V.VG130.711.5F20C4	711
FSG-V.VG130.849.5F20C4	849
FSG-V.VG130.988.5F20C5	988
FSG-V.VG130.1126.5F20C6	1,126
FSG-V.VG130.1265.5F20C6	1,265
FSG-V.PG130.434.5F20C2	434
FSG-V.PG130.572.5F20C3	572
FSG-V.PG130.711.5F20C4	711
FSG-V.PG130.849.5F20C4	849
FSG-V.PG130.988.5F20C5	988
FSG-V.PG130.1126.5F20C6	1,126
FSG-V.PG130.1265.5F20C6	1,265



# Vacuum gripping systems | Area gripper FSG

Replacement foam for area gripper FSG

## Replacement foam for area gripper FSG



### Product notes

- > Material EPDM, resistant to weathering, ozone and most acids and alkalis. Not resistant to oils and greases.
- > Good stand-up behaviour for short cycle times.
- > Applied on strong self-adhesive film for quick and easy replacement of the foam on the area gripper
- > The foam on the film comes off the area gripper without leaving residues
- > As filter foam with plastic fabric with hole size 0.1 mm for applications in dusty and dirty environments – on request
- > As valve foam for handling cans, jars, bottles, etc. – on request

### Technical data

Item no.	Model	Number of suction cells
FSG.ACC130.295.5F20	Standard foam	53
FSG.ACC130.434.5F20	Standard foam	83
FSG.ACC130.572.5F20	Standard foam	113
FSG.ACC130.711.5F20	Standard foam	143
FSG.ACC130.849.5F20	Standard foam	173
FSG.ACC130.988.5F20	Standard foam	203
FSG.ACC130.1126.5F20	Standard foam	233
FSG.ACC130.1265.5F20	Standard foam	263
FSG.ACC130.295.5F20F	Filter foam	53
FSG.ACC130.434.5F20F	Filter foam	83
FSG.ACC130.572.5F20F	Filter foam	113
FSG.ACC130.711.5F20F	Filter foam	143
FSG.ACC130.849.5F20F	Filter foam	173
FSG.ACC130.988.5F20F	Filter foam	203
FSG.ACC130.1126.5F20F	Filter foam	233
FSG.ACC130.1265.5F20F	Filter foam	263
FSG.ACC130.295.5F20V	Valve foam	53
FSG.ACC130.434.5F20V	Valve foam	83
FSG.ACC130.572.5F20V	Valve foam	113
FSG.ACC130.711.5F20V	Valve foam	143
FSG.ACC130.849.5F20V	Valve foam	173
FSG.ACC130.988.5F20V	Valve foam	203
FSG.ACC130.1126.5F20V	Valve foam	233
FSG.ACC130.1265.5F20V	Valve foam	263

### Dimensions

A [mm]	B [mm]	C [mm]	Ø D [mm]
295	130	20	16
434	130	20	16
572	130	20	16
711	130	20	16
849	130	20	16
988	130	20	16
1,126	130	20	16
1,265	130	20	16
295	130	10F10	16
434	130	10F10	16
572	130	10F10	16
711	130	10F10	16
849	130	10F10	16
988	130	10F10	16
1,126	130	10F10	16
1,265	130	10F10	16
295	130	20	2 - 10
434	130	20	2 - 10
572	130	20	2 - 10
711	130	20	2 - 10
849	130	20	2 - 10
988	130	20	2 - 10
1,126	130	20	2 - 10
1,265	130	20	2 - 10



## Dimensions

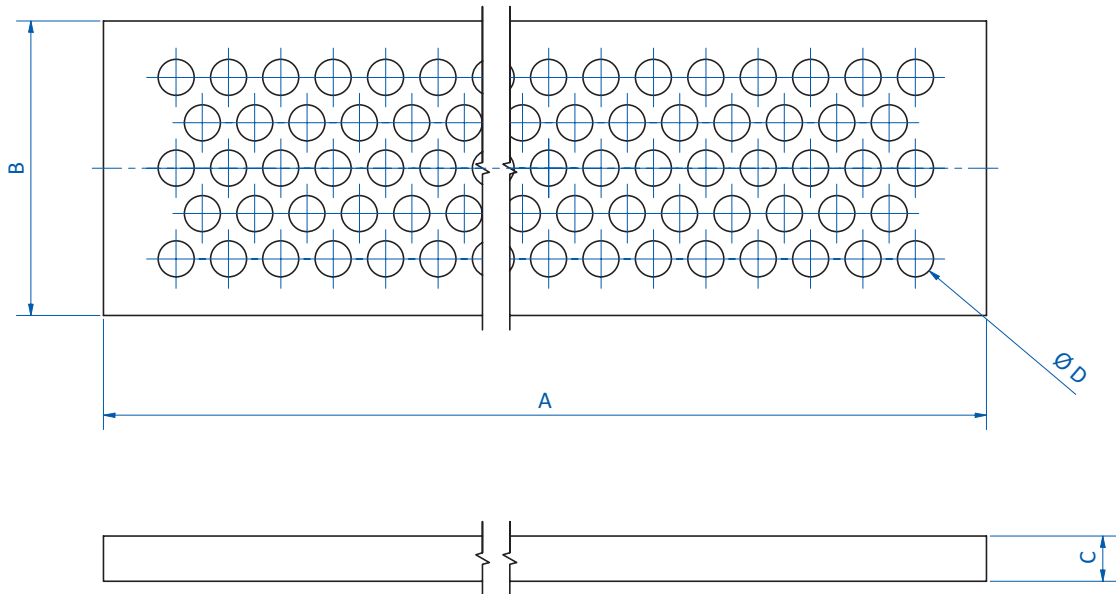



# Vacuum gripping systems | Area gripper FSG

Set of replacement vacuum cups for area gripper FSG

## Set of replacement vacuum cups for area gripper FSG

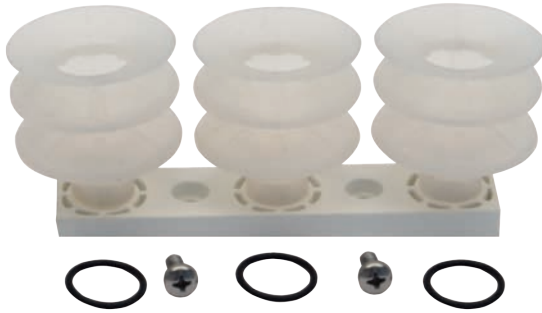

### Product notes

- > Complete set of pre-assembled replacement vacuum cups for area gripper FSG.
- > The set contains the correct number of vacuum cups made of silicone 55° Shore, mounting strips, sealing rings and screws depending on the length of the gripper.
- > The spare vacuum cups are pre-mounted on mounting strips.
- > The mounting strips can be very easily screwed onto the area gripper with just a few screws.
- > **Advantage:** Great time savings when replacing the vacuum cups on the area gripper.

### Technical data

Item no.	Diameter vacuum cups [mm]	Number of vacuum cups	For area grippers with length [mm]
<b>FSG.ACC130.295.3C02</b>	40	17	295
<b>FSG.ACC130.434.3C02</b>	40	26	434
<b>FSG.ACC130.572.3C02</b>	40	35	572
<b>FSG.ACC130.711.3C02</b>	40	44	711
<b>FSG.ACC130.849.3C02</b>	40	53	849
<b>FSG.ACC130.988.3C02</b>	40	62	988
<b>FSG.ACC130.1126.3C02</b>	40	71	1,126
<b>FSG.ACC130.1265.3C02</b>	40	80	1,265
<b>FSG.ACC130.295.5C02</b>	20	53	295
<b>FSG.ACC130.434.5C02</b>	20	83	434
<b>FSG.ACC130.572.5C02</b>	20	113	572
<b>FSG.ACC130.711.5C02</b>	20	143	711
<b>FSG.ACC130.849.5C02</b>	20	173	849
<b>FSG.ACC130.988.5C02</b>	20	203	988
<b>FSG.ACC130.1126.5C02</b>	20	233	1,126
<b>FSG.ACC130.1265.5C02</b>	20	263	1,265



### Sensor set for area gripper FSG



#### Product notes

- > Enables simple and reliable checking of part presence by means of an optical sensor.
- > The sensor is mounted on the large-area gripper by means of a sliding block. This allows the sensor to be positioned anywhere along the surface gripper.
- > The switching distance of the sensor can be easily adjusted continuously (30 - 300 mm).
- > Includes the optical sensor, a mounting bracket, a slot nut and all necessary screws and small parts.
- > Electrical connection with M8 plug 3-pole

#### Technical data

Item no.	Plug	Sensor	Cable length [mm]	Switching distance [mm]	Operating voltage [VDC]	Current consumption [mA]	Operating temperature [°C (°F)]
<b>FSG.ACC130.0004</b>	M8	PNP	200	30 - 300	10 - 30	30	-25 - 60 (-13 - 140)

#### Dimensions

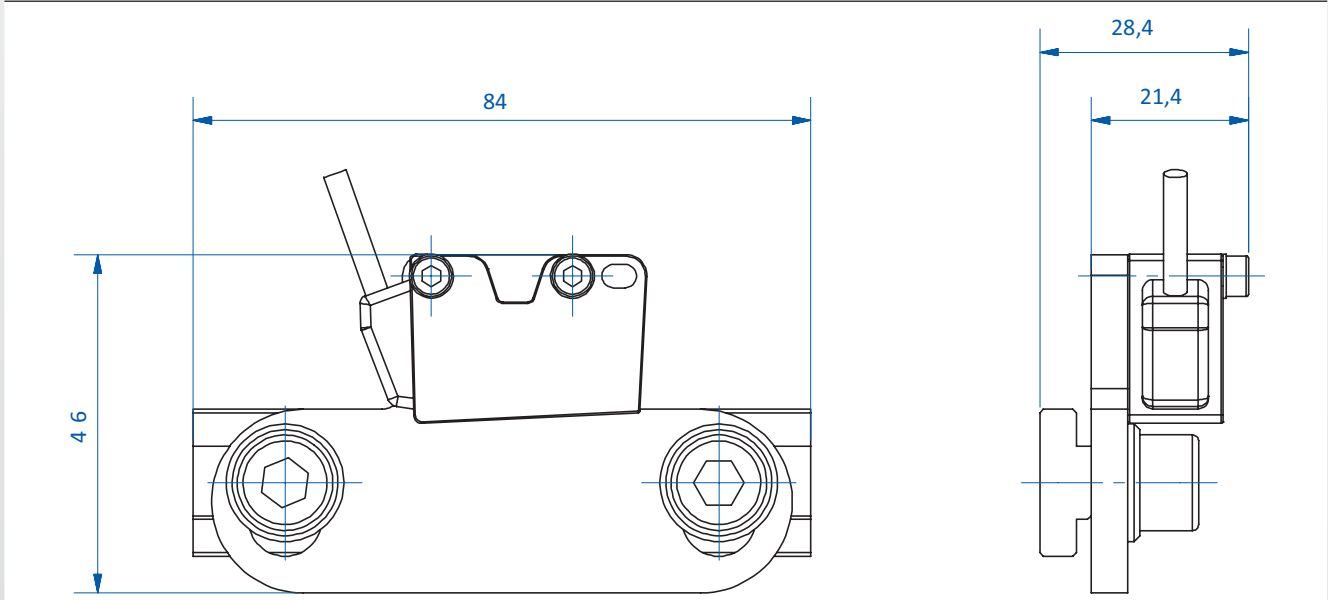



### Flange modul for area gripper FSG



#### Product notes

- > The flange module enables easy mounting of a area gripper FSG on a quickchanger of the SR series.
- > All quickchanger of the SR series fit on the flange module - but please ensure that the quickchanger is not overloaded in your application.
- > Made of steel, powder coated black
- > Including mounting material for attachment to the area gripper

#### Technical data

Item no.	Weight [g]
<b>FSG.ACC130.0001</b>	500

#### Dimensions

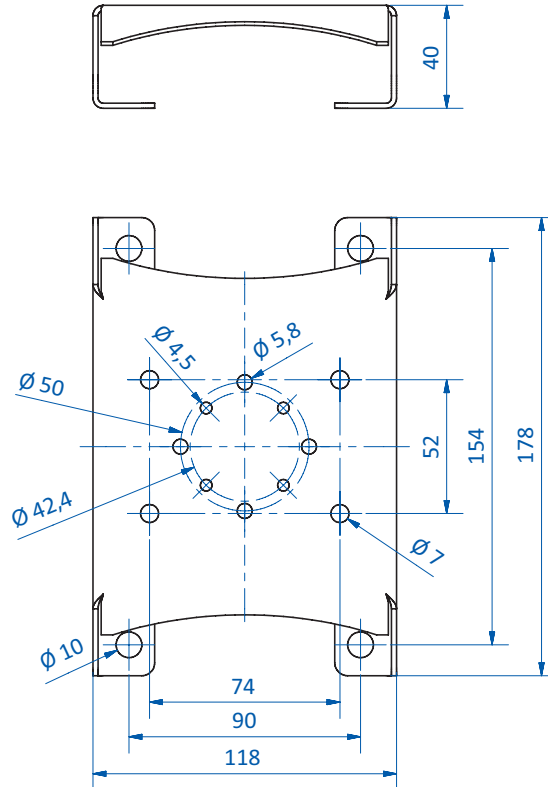





### Bag grippers

Handling of non-rigid goods

**MAXIMUM DURABILITY, MINIMUM MAINTENANCE**



View of the suction chamber

#### Product notes

- > Handling of limp, non-rigid objects such as bags, shrink-wraps or any product that fully covers the suction chamber
- > On board vacuum generation via high performance ejectors for optimum suction power
- > Dust-resistant design
- > Sealing foam with optimum adjustment to product surface – easy to replace
- > Optional side channel blower for handling very porous goods

#### Notes

On request:

- > Splitting of suction chamber for multi-zone picking and release
- > Depth of the suction chamber can be adjusted for optimum handling of specific products (standard 40 mm)

#### Ordering notes

Ordering example vacuum generation

- > TG150x300: integrated via ejectors
- > TG150x300-OV: designed for external vacuum generation, e.g. via side channel blower or pump

#### Technical data

Item no.	Air consumption at 6 bar (87 psi) [Nl/min]	Suction power against atmosphere [Nl/min]	Final vacuum [%]	Max. gripping force at 60 % vacuum (-600 mbar (-17.7 inHg)) safety factor 1.5 [N]			Weight [kg]	Suitable sealing foam
				Dense products (e.g. steel)	Semi-porous products (e.g. wood)	Porous products (e.g. carton boxes)		
<b>TG100x250</b>	105	198	85	280	170	70	1.5	PPF100x250
<b>TG150x300</b>	210	396	85	500	300	125	2.5	PPF150x300
<b>TG200x350</b>	210	396	85	770	470	190	3.5	PPF200x350
<b>TG250x400</b>	210	396	85	1,100	670	270	4.7	PPF250x400
<b>TG300x500</b>	210	396	85	1,670	1,000	400	6.7	PPF300x500
<b>TG400x600</b>	210	396	85	2,670	1,600	625	14.7	PPF400x600

Continued on the next page →



### Sealing foam

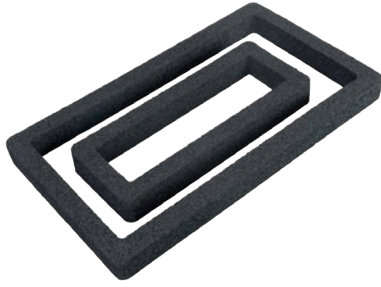

Easy replacement of sealing foam

### Dimensions

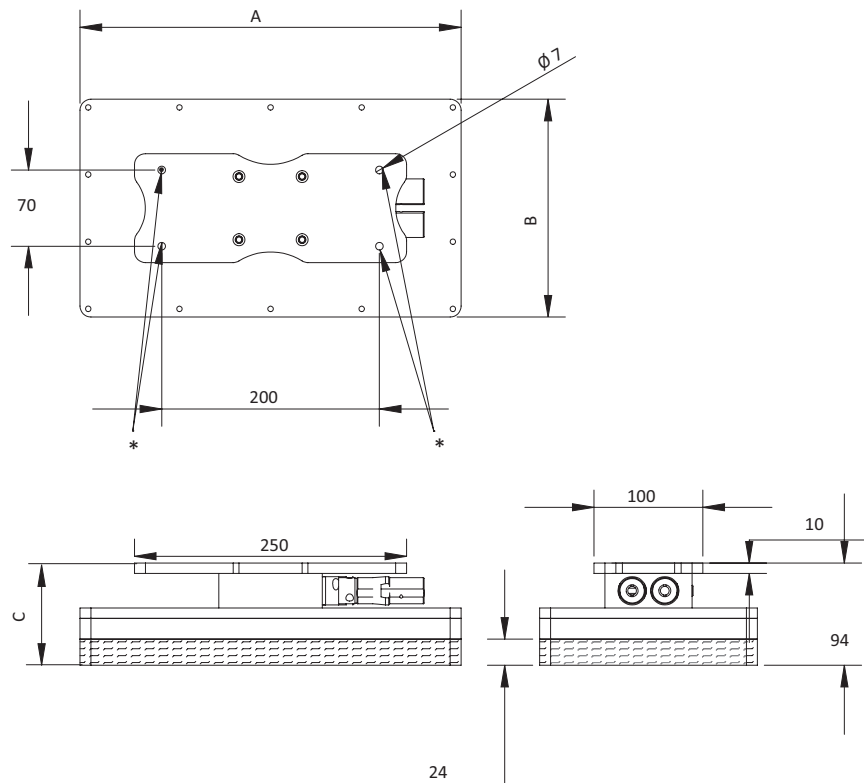

\* = Fixing holes for connection to gripper system

Item no.	A [mm]	B [mm]	C [mm]
<b>TG100x250</b>	250	100	62
<b>TG150x300</b>	300	150	62
<b>TG200x350</b>	350	200	62
<b>TG250x400</b>	400	250	93
<b>TG300x500</b>	500	300	93
<b>TG400x600</b>	600	400	93



## FORMHAND for robots



### Product notes

- > Gripping pad filled with a freely movable granulate made of plastic for handling complex and changing geometries
- > The FORMHAND nestles seamlessly to the surface of the component and thus ensures a gentle grip
- > Application on classic industrial robots, but also on cobots
- > Saving of different gripping systems and set-up times due to the modular use of this universal gripper

### Notes

- > The holding force corresponds to optimal conditions, can deviate downwards

### Technical data

Item no.	Suction area [mm]	Pipe connection [mm]	Material	Max. gripping force [N]	Weight [kg]	Ambient air temperature [°C (°F)]
FMG.FH.R80.5	∅ 80	32	PU	20	0.45	-10 - 50 (14 - 122)
FMG.FH.R150.5	∅ 154	32	PU	80	2.65	-10 - 50 (14 - 122)
FMG.FH.R150.1	∅ 154	32	NBR	80	2.65	-10 - 50 (14 - 122)
FMG.FH.E3020.5	300x200	32	PU	250	3.7	-10 - 50 (14 - 122)

### Application examples



Continued on the next page →



## Dimensions

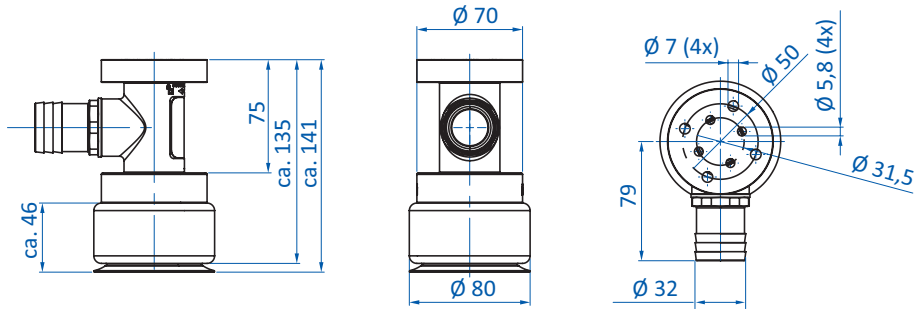

FMG.FH.R80.5

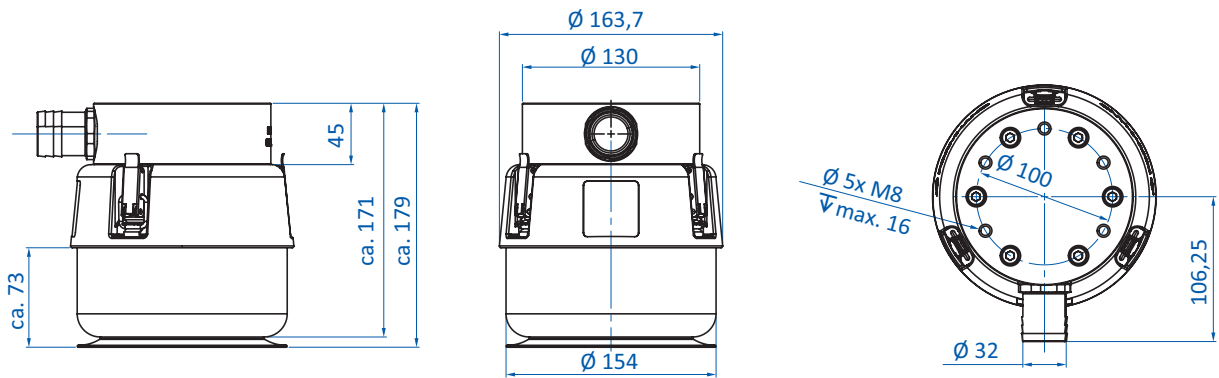

FMG.FH.R150.5 | FMG.FH.R150.1

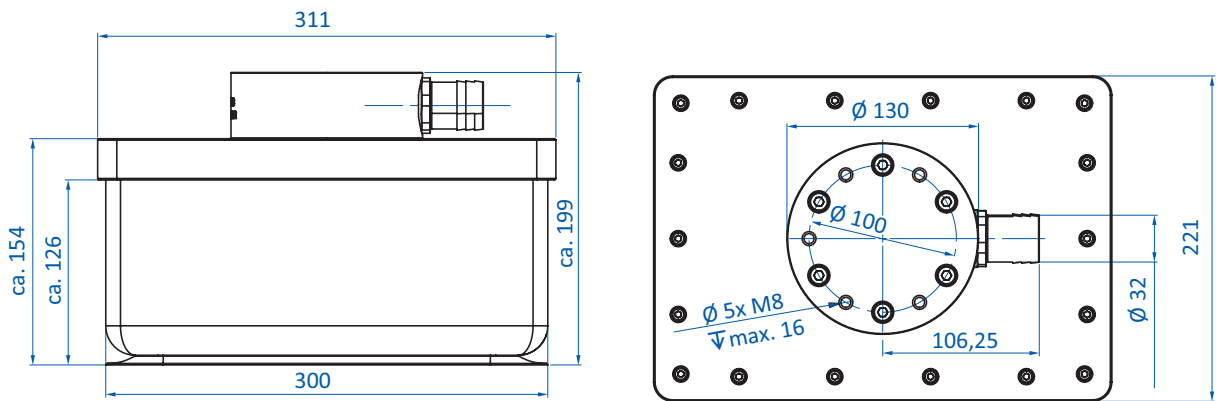

FMG.FH.E3020.5

Sensors .....	372
Cables and plugs .....	383
Reflective sensors .....	394
Signal transmitters .....	398
Signal converters .....	403



### Magnetic sensors for T-slot



GR04.203P

#### Product notes

- > T-slot sensors for active gripping elements, linear units, compact cylinders
- > PNP or NPN switching functions
- > Integrated control LED
- > Quick and easy to install

#### Technical data

Item no.	GR04.199	GR04.199/NPN	GR04.203P	GR04.203N
Switching output	PNP	NPN	PNP	NPN
Type	straight	straight	straight, short	straight, short
Operating voltage [VDC]	10 - 30	10 - 30	5 - 30	5 - 30
Max. switching current [mA]	100	100	200	200
Idle current [mA]	8 at 24 V DC	8 at 24 V DC	6 at 24 V DC	6 at 24 V DC
Max. power consumption [W]	3	3	6	6
Max. voltage drop [V]	1.5 at 50 mA	1.5 at 50 mA	0.5 at 200 mA	0.5 at 200 mA
Max. switching frequency [Hz]	1,000	1,000	1,000	1,000
Magnetic switch point [Gauss]	45	45	40	40
Switching logic	Contact (NO)	Contact (NO)	Contact (NO)	Contact (NO)
Teach-in	no	no	no	no
Reverse polarity protection	yes	yes	yes	yes
Short-circuit protection	yes	yes	no	no
Surge Suppression	yes	yes	yes	yes
Protection class	IP67	IP67	IP67	IP67
Shock resistance	50 G, 11 ms	50 G, 11 ms	50 G, 11 ms	50 G, 11 ms
Fibration resistance	9 G, 10 - 55 Hz, 1,5 mm	9 G, 10 - 55 Hz, 1,5 mm	9 G, 10 - 55 Hz, 1,5 mm	9 G, 10 - 55 Hz, 1,5 mm
Cable length [mm]	150	150	150	150
Electric connection	3-pin male M8 connector	3-pin male M8 connector	3-pin male M8 connector	3-pin male M8 connector
Operating temperature [°C (°F)]	-10 - 70 (14 - 158)	-10 - 70 (14 - 158)	-10 - 70 (14 - 158)	-10 - 70 (14 - 158)
Weight [g]	25	25	27	27
Accessories	Connecting cable: 20.503 Connecting cable: 20.507 Extension cable: 20.570 Extension cable: 20.504	Connecting cable: 20.503 Connecting cable: 20.507 Extension cable: 20.570 Extension cable: 20.504	Connecting cable: 20.503 Connecting cable: 20.507 Extension cable: 20.570 Extension cable: 20.504	Connecting cable: 20.503 Connecting cable: 20.507 Extension cable: 20.570 Extension cable: 20.504



**Connection and extension cables**

- > 20.503: M8, 3-pin, female straight, length 2,500 mm, open cable
- > 20.507: M8, 3-pin, female 90° angled, length 2,000 mm, open cable
- > 20.504: M8, 3-pin, female straight, length 300 mm, end with M8, 3-pin, male 90° angled
- > 20.570: M8, 3-pin, female straight, length 1,500 mm, end with M8, 3-pin, male straight

**Pin assignment and connection diagram for PNP GR04.199 und GR04.203**

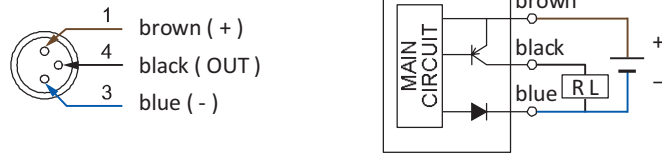

**Pin assignment and connection diagram for NPN GR04.199 und GR04.203**



**Dimensions**

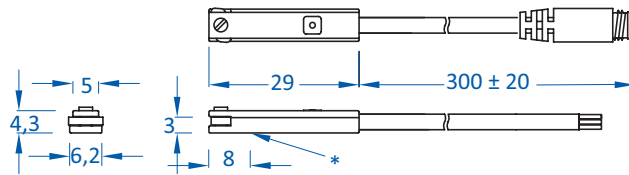

GR04.199 | GR04.199/NPN

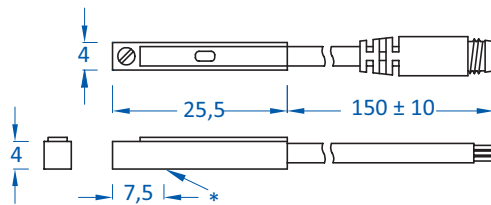

GR04.203P | GR04.203N

\* = Sensing point



### Matching nut dimensions

> GR04.199

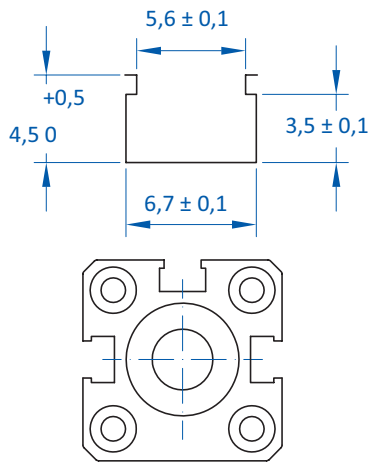

> GR04.203

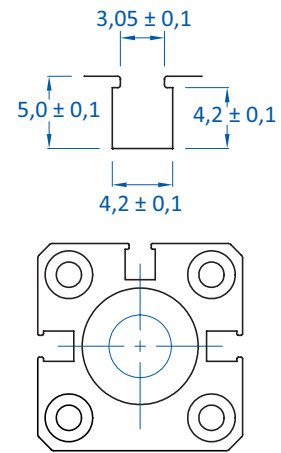





## Magnetic sensors for C-slot



GS04.005

**Product notes**

- > C-slot sensors for active gripping elements, linear units, compact cylinders
- > PNP or NPN switching functions
- > GS04.005 and GS04.006 with two teachable switching points
- > Integrated control LED
- > Quick and easy to install

**Technical data**

Item no.	GS04.005	GS04.006	GR04.198	GR04.198/NPN	GR04.202P	GR04.202N	GR04.280P	GR04.280N	GR04.209P
Switching output	PNP	NPN	PNP	NPN	PNP	NPN	PNP	NPN	PNP
Type	straight	straight	straight	straight	90° elbow	90° elbow	straight, short	straight, short	90° elbow
Operating voltage [VDC]	12 - 30	12 - 30	6 - 30	6 - 30	5 - 30	5 - 30	4.5 - 28	4.5 - 28	5 - 30
Max. switching current [mA]	100	100	200	200	50	50	50	50	80
Idle current [mA]	20	20	10 at 24 V DC	10 at 24 V DC	9 at 24 V DC	7 at 24 V DC	10 at 24 V DC	10 at 24 V DC	6 at 24 V DC
Max. power consumption [W]	3.45	3.45	6	6	1.5	1.5	1.5	1.5	2.3
Max. voltage drop [V]	2.2	2.2	0.5 at 50 mA	0.5 at 50 mA	1.5 at 50 mA	1.5 at 50 mA	0.5 at 50 mA	0.5 at 50 mA	0.5 at 50 mA
Max. switching frequency [Hz]	1,000	1,000	1,000	1,000	1,000	1,000	1,000	1,000	1,000
Detection range [mm]	0 - 50	0 - 50	--	--	--	--	--	--	--
Magnetic switch point [Gauss]	--	--	40	40	40	40	40	40	40
Switching logic	Contact (NO)	Contact (NO)	Contact (NO)	Contact (NO)	Contact (NO)	Contact (NO)	Contact (NO)	Contact (NO)	Contact (NO)
Teach-in	yes	yes	no	no	no	no	no	no	no
Reverse polarity protection	yes	yes	yes	yes	yes	yes	yes	yes	no
Short-circuit protection	yes	yes	no	no	no	no	no	no	no
Surge Suppression	yes	yes	yes	yes	yes	yes	yes	yes	yes
Protection class	IP67	IP67	IP67	IP67	IP67	IP67	IP67	IP67	IP67
Shock resistance	30 G, 11 ms	30 G, 11 ms	50 G, 11 ms	50 G, 11 ms	50 G, 11 ms	50 G, 11 ms	50 G, 11 ms	50 G, 11 ms	--

Continued on the next page →



### Technical data

Item no.	GS04.005	GS04.006	GR04.198	GR04.198/NPN	GR04.202P	GR04.202N	GR04.280P	GR04.280N	GR04.209P
Fibration resistance	10 - 55 Hz, 1 mm	10 - 55 Hz, 1 mm	9 G, 10 - 55 Hz, 1,5 mm	9 G, 10 - 55 Hz, 1,5 mm	9 G, 10 - 55 Hz, 1,5 mm	9 G, 10 - 55 Hz, 1,5 mm	9 G, 10 - 55 Hz, 1,5 mm	9 G, 10 - 55 Hz, 1,5 mm	--
Cable length [mm]	500	500	300	300	150	150	150	150	2,000
Electric connection	4-pin male M8 connector	4-pin male M8 connector	3-pin male M8 connector	3-pin male M8 connector	3-pin male M8 connector	3-pin male M8 connector	3-pin male M8 connector	3-pin male M8 connector	3-pin, unterminated cable, 26AWG
Operating temperature [°C (°F)]	-20 - 75 (-4 - 167)	-20 - 75 (-4 - 167)	-10 - 70 (14 - 158)	-10 - 70 (14 - 158)	-10 - 70 (14 - 158)	-10 - 70 (14 - 158)	-10 - 70 (14 - 158)	-10 - 70 (14 - 158)	-10 - 70 (14 - 158)
Weight [g]	11	11	18	18	25	25	21	21	21.5
Accessories	Connecting cable: 20.501 Connecting cable: 20.502	Connecting cable: 20.501 Connecting cable: 20.502	Connecting cable: 20.503 Connecting cable: 20.507 Extension cable: 20.570 Extension cable: 20.504	Connecting cable: 20.503 Connecting cable: 20.507 Extension cable: 20.570 Extension cable: 20.504	Connecting cable: 20.503 Connecting cable: 20.507 Extension cable: 20.570 Extension cable: 20.504	Connecting cable: 20.503 Connecting cable: 20.507 Extension cable: 20.570 Extension cable: 20.504	Connecting cable: 20.503 Connecting cable: 20.507 Extension cable: 20.570 Extension cable: 20.504	Connecting cable: 20.503 Connecting cable: 20.507 Extension cable: 20.570 Extension cable: 20.504	Plug connector: 20.527

### Connection and extension cables

20.503: M8, 3-pin, female straight, length 2,500 mm, open cable  
 20.507: M8, 3-pin, female 90° angled, length 2,000 mm, open cable  
 20.504: M8, 3-pin, female straight, length 300 mm, end with M8, 3-pin, male 90° angled  
 20.570: M8, 3-pin, female straight, length 1,500 mm, end with M8, 3-pin, male straight  
 20.501: M8, 4-pin, female straight, length 5,000 mm, open cable  
 20.502: M8, 4-pin, female 90° angled, length 5,000 mm, open cable

### Pin assignment and connection diagram for GS04.005

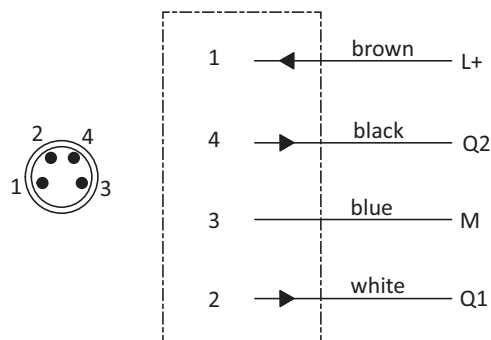

### Pin assignment and connection diagram for GS04.006

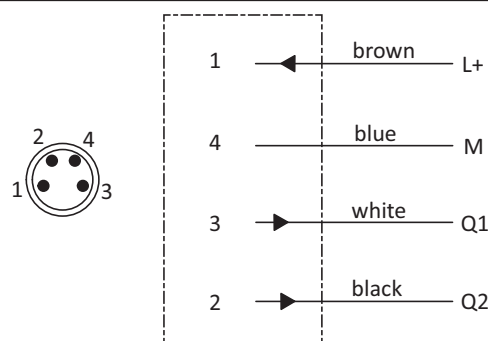



Pin assignment and connection diagram for PNP GR04.198, GR04.202 und GR04.280

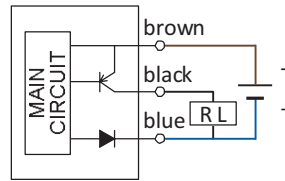
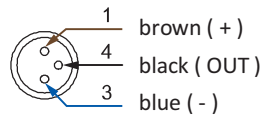

Pin assignment and connection diagram for GR04.198/NPN

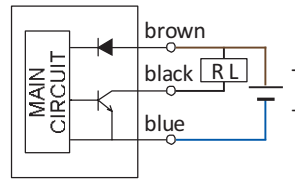
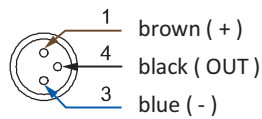

Connection diagram for GR04.209P

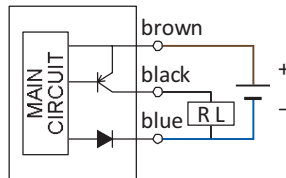

Application example



Dimensions

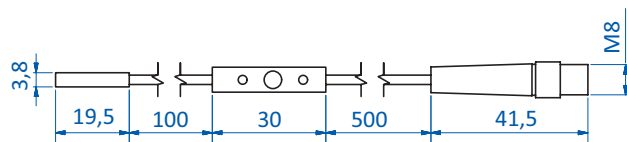

GS04.005 | GS04.006

\* = Sensing point ① = Screw ② = Sensitive range

Continued on the next page →



### Dimensions

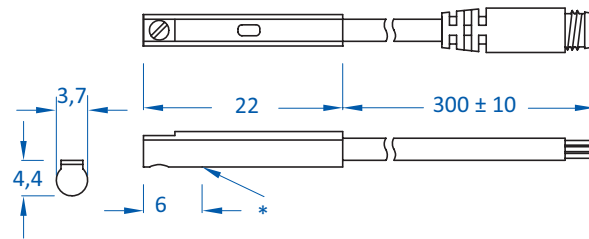

GR04.198 | GR04.198/NPN

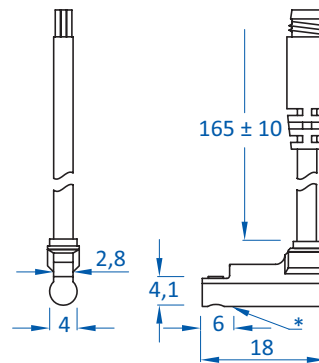

GR04.202P | GR04.202N

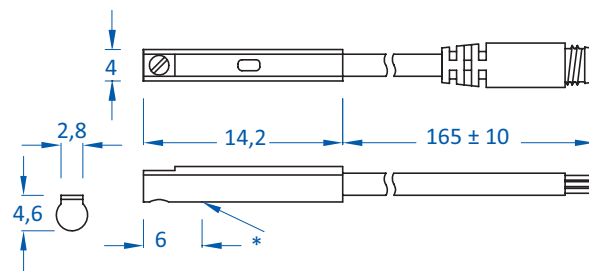

GR04.280P | GR04.280N

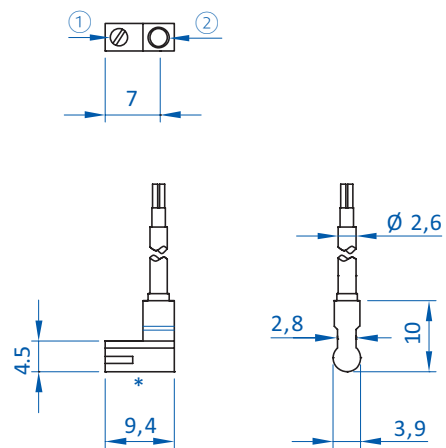

GR04.209P

\* = Sensing point ① = Screw ② = Sensitive range



Matching nut dimensions

> GS04.005 | GS04.006 | GR04.198

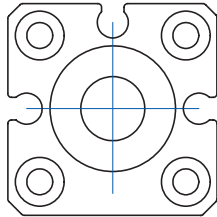
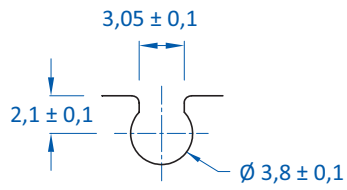

> GR04.202 | GR04.280 | GR04.209

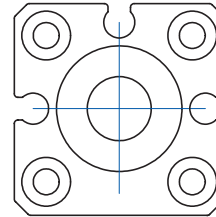
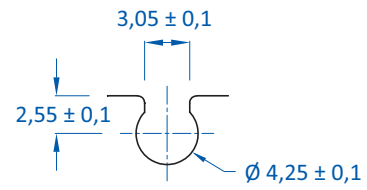



### Inductive sensors



GS04.001



GS04.007

### Product notes

- > PNP or NPN switching functions
- > Integrated control LED

### Technical data

Item no.	GS04.001	GS04.002	GS04.007	GS04.008	GS04.009	GS04.010	GR04.193P	GR04.193N
Switching output	PNP	NPN	PNP	NPN	PNP	NPN	PNP	NPN
Type	straight	straight	straight	straight	straight	straight	straight	straight
Nut-Model	T	T	C	C	C	C	C	C
Operating voltage [VDC]	10 - 30	10 - 30	10 - 30	10 - 30	10 - 30	10 - 30	10 - 30	10 - 30
Max. switching current [mA]	150	150	100	100	200	200	200	200
Idle current [mA]	15	15	10	10	10	10	10	10
Max. voltage drop [V]	1.8	1.8	2 at 100 mA	2 at 100 mA	1.5	1.5	1.5	1.5
Max. switching frequency [Hz]	2,000	2,000	8,000	8,000	2,000	2,000	2,000	2,000
Switching distance [mm]	2	2	1	1	0.8	0.8	0.8	0.8
Switching logic	Contact (NO)	Contact (NO)	Contact (NO)	Contact (NO)	Contact (NO)	Contact (NO)	Contact (NO)	Contact (NO)
Reverse polarity protection	yes	yes	yes	yes	yes	yes	yes	yes
Short-circuit protection	yes	yes	yes	yes	yes	yes	yes	yes
Protection class	IP67	IP67	IP67	IP67	IP67	IP67	IP67	IP67
Shock resistance	30 G, 11 ms	30 G, 11 ms	30 G, 11 ms	30 G, 11 ms	30 G, 11 ms	30 G, 11 ms	30 G, 11 ms	30 G, 11 ms
Fibration resistance	55 Hz, 1 mm	55 Hz, 1 mm	55 Hz, 1 mm	55 Hz, 1 mm	55 Hz, 1 mm	55 Hz, 1 mm	55 Hz, 1 mm	55 Hz, 1 mm
Cable length [mm]	200	200	200	200	300	300	2,000	2,000
Electric connection	3-pin male M8 connector	3-pin male M8 connector	3-pin male M8 connector	3-pin male M8 connector	3-pin male M8 connector	3-pin male M8 connector	3-pin, unterminated cable	3-pin, unterminated cable
Operating temperature [°C (°F)]	-25 - 85 (-13 - 185)	-25 - 80 (-13 - 176)	-25 - 70 (-13 - 158)	-25 - 70 (-13 - 158)	-25 - 70 (-13 - 158)	-25 - 70 (-13 - 158)	-25 - 70 (-13 - 158)	-25 - 70 (-13 - 158)
Weight [g]	38	38	16	16	13	13	25	25



Technical data

Item no.	GS04.001	GS04.002	GS04.007	GS04.008	GS04.009	GS04.010	GR04.193P	GR04.193N
Accessories	Connecting cable: 20.503 Connecting cable: 20.507 Extension	Connecting cable: 20.503 Connecting cable: 20.507 Extension	Connecting cable: 20.503 Connecting cable: 20.507 Extension	Connecting cable: 20.503 Connecting cable: 20.507 Extension	Connecting cable: 20.503 Connecting cable: 20.507 Extension	Connecting cable: 20.503 Connecting cable: 20.507 Extension	Plug connector: 20.527	Plug connector: 20.527

Connection diagram for GS04.007 and GS04.008

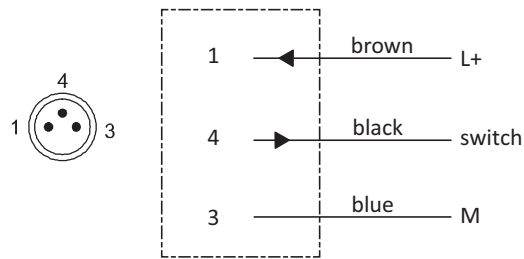

Pin assignment and connection diagram for PNP GS04.001, GS04.009 und GR04.193

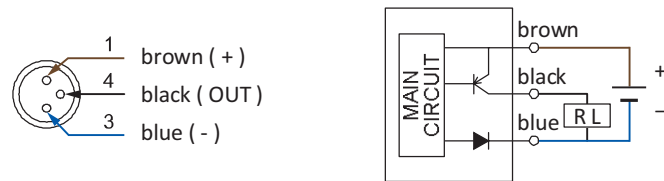

Pin assignment and connection diagram for NPN GS04.002, GS04.010 und GR04.193

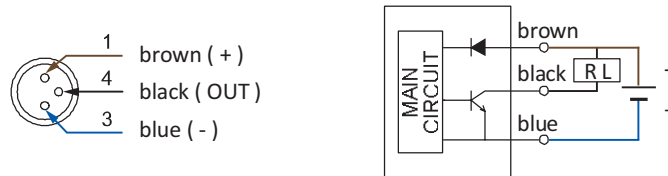

Dimensions

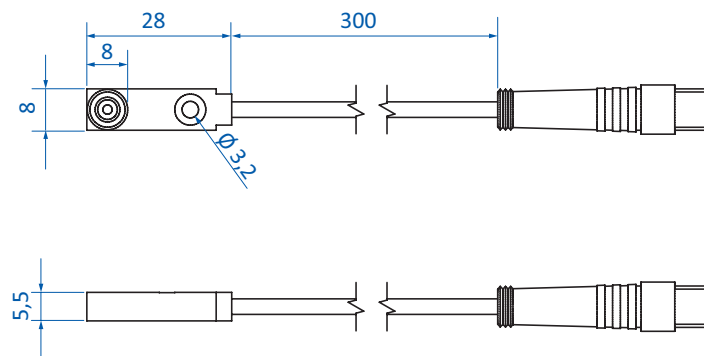

GS04.001 | GS04.002



### Dimensions

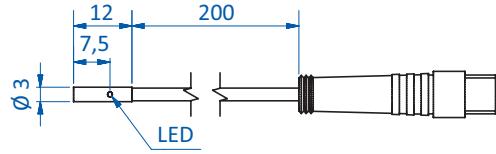

GS04.007 | GS04.008

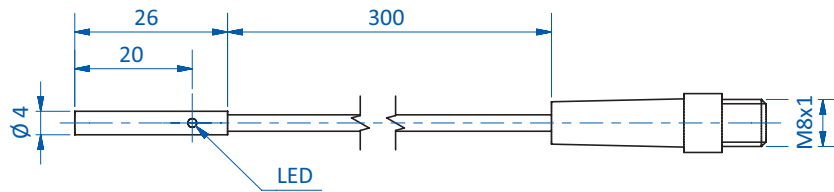

GS04.009 | GS04.010

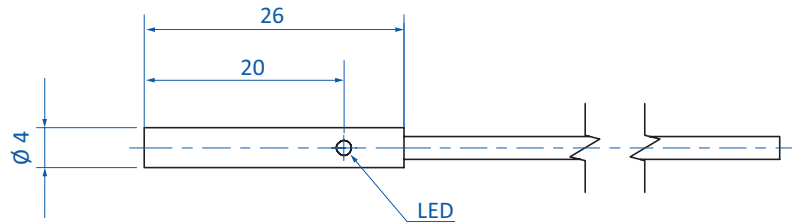

GR04.193P | GR04.193N





Connecting cable

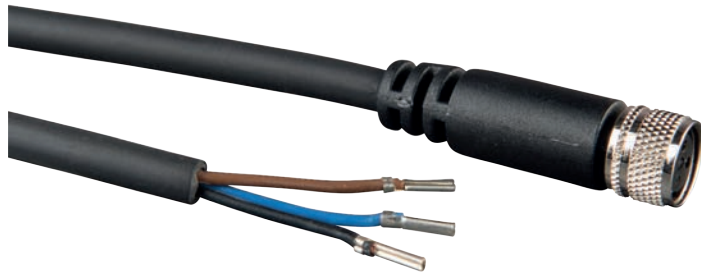

Product notes

- > Open wire for manual wiring to sensor relay boxes and terminals
- > Automation-grade PUR cables

Technical data

Item no.	Electric connection	Type	Cable length [mm]
20.503	M8, 3-pin, female / open cable	straight	2,000
20.507	M8, 3-pin, female / open cable	90° elbow	2,000
20.501	M8, 4-pin, female / open cable	straight	5,000
20.502	M8, 4-pin, female / open cable	90° elbow	5,000
20.518	M12, 4-pin, female / open cable	straight	2,000
20.519	M12, 4-pin, female / open cable	90° elbow	2,000
20.508	M12, 5-pin, female / open cable	straight	2,000
20.509	M12, 5-pin, female / open cable	90° elbow	2,000
20.558	M12, 8-pin, female / open cable	90° elbow	2,000

Wiring diagram and Pin assignment for 20.503 and 20.507

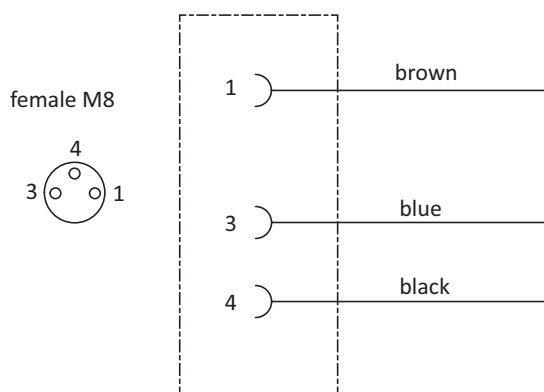

Continued on the next page



### Wiring diagram and Pin assignment for 20.501 and 20.502

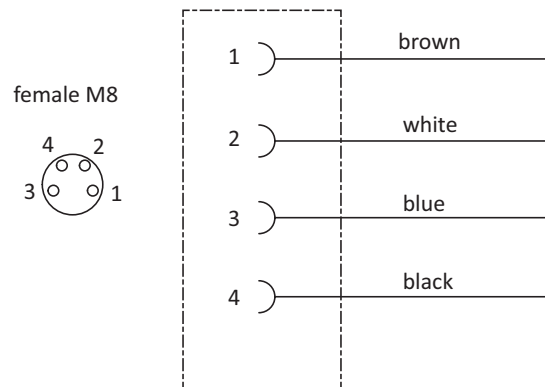

### Wiring diagram and Pin assignment for 20.508 and 20.509

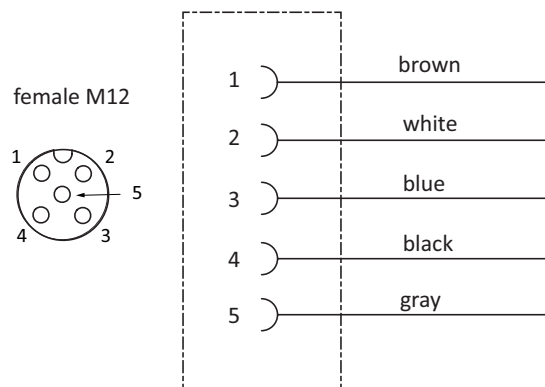

### Wiring diagram and Pin assignment for 20.518 and 20.519

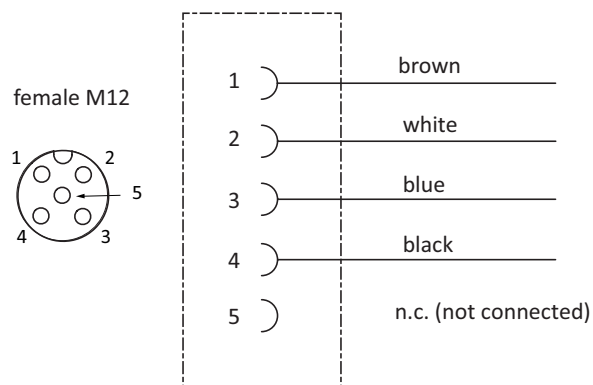



Wiring diagram and Pin assignment for 20.558

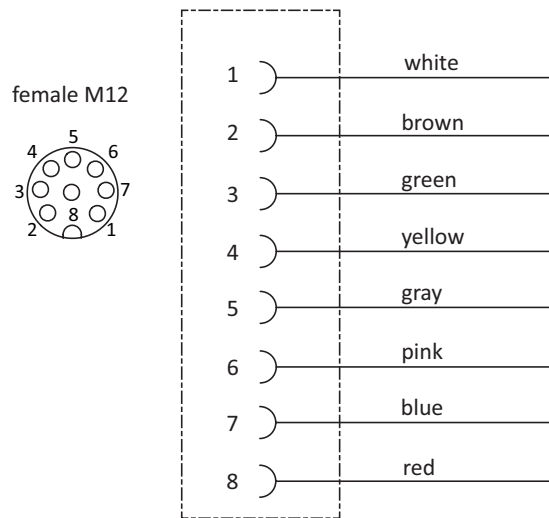



### Extension cable



### Product notes

- > Simple connection of sensors or ejectors to M8 or M12 inputs or outputs
- > Automation-grade PUR cables

### Technical data

Item no.	Electric connection	Type	Cable length [mm]
20.504	M8, 3-pin, female / M8, 3-pin, male	straight / 90° elbow	300
20.570	M8, 3-pin, female / M8, 3-pin, male	straight / straight	1,500
20.551	M8, 4-pin, female / M8, 4-pin, male	straight / straight	2,000
20.552	M12, 5-pin, female / M12, 5-pin, male	straight / straight	2,000

### Pin assignment and connection diagram for 20.504

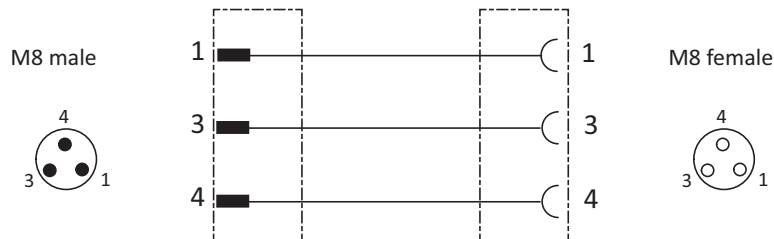

### Pin assignment and connection diagram for 20.570

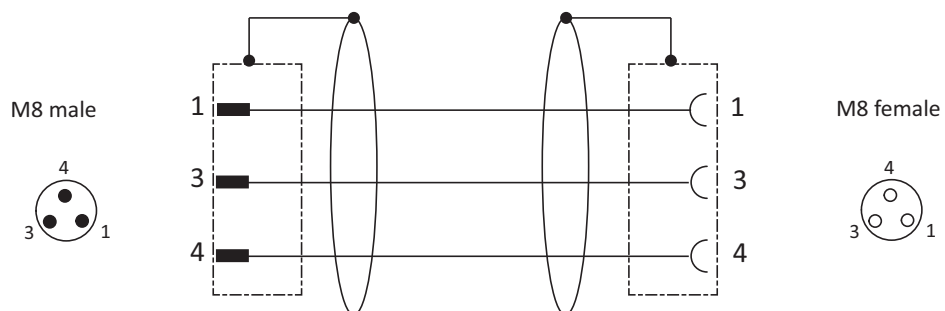



Pin assignment and connection diagram for 20.551

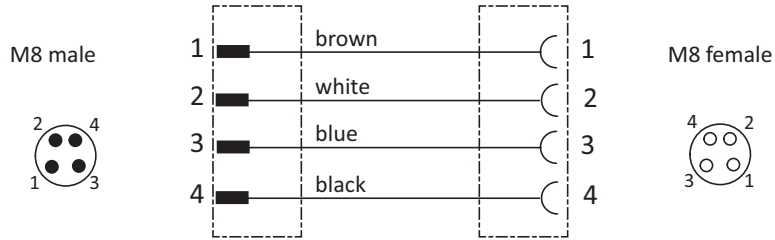

Pin assignment and connection diagram for 20.552

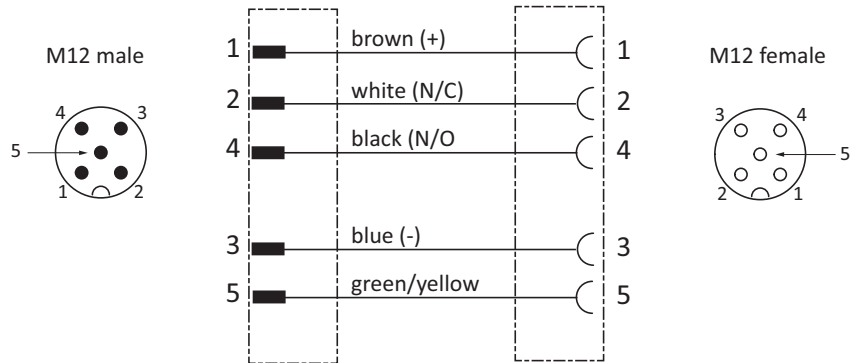



### Plug connectors M8/3-pin



#### Product notes

> The plug connector enables open cable ends to be connected to a connector

#### Technical data

Item no.	Electric connection	Weight [g]
20.527	Plug	5
20.528	Socket	5

#### Dimensions

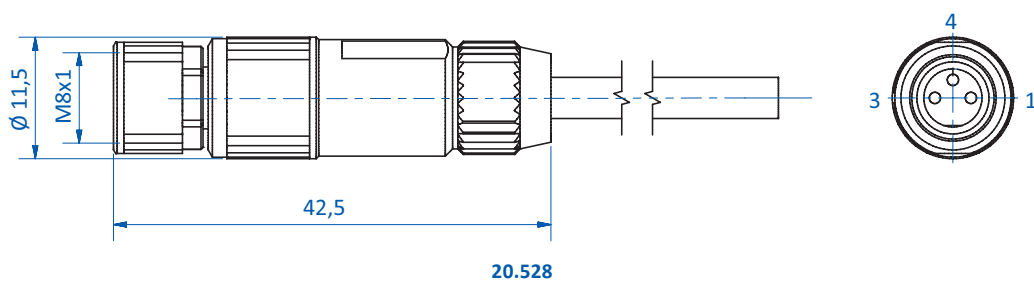
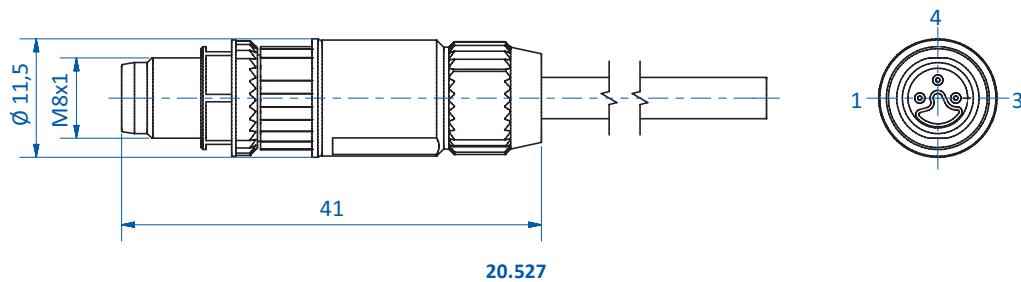



Adapter plug



Product notes

> Connect electric devices with mismatching connectors without the need for manual wiring

Technical data

Item no.	Electric connection	Cable length [mm]	Weight [g]
<b>M8B3 / M8S4</b>	M8, 3-pin, female / M8, 4-pin, male	--	10
<b>M8B4 / M8S3</b>	M8, 4-pin, female / M8, 3-pin, male	--	10
<b>20.553</b>	M8, 4-pin, female / 2x M8, 3-pin, male	300	38
<b>20.554</b>	M12, 5-pin, female / 2x M8, 3-pin, male	300	47
<b>20.555</b>	2x M8, 3-pin, female / M12, 4-pin, male	--	21
<b>20.556</b>	M8, 4-pin, female / M12, 4-pin, male	--	13

Wiring diagram and Pin assignment for M8B3 / M8S4

M8 female

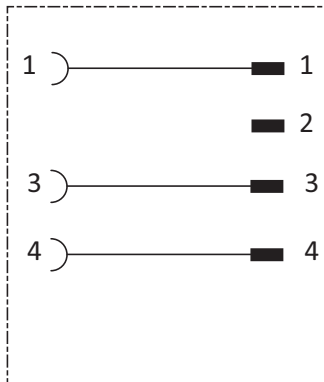

M8 male

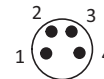

Continued on the next page



### Wiring diagram and Pin assignment for M8B4 / M8S3

M8 female

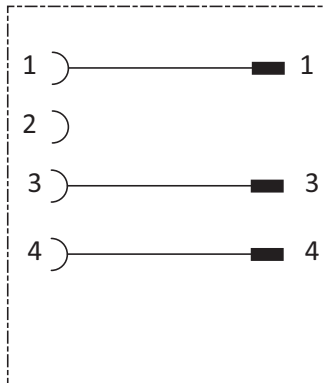

M8 male

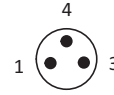

### Wiring diagram and Pin assignment for 20.553

M8 male

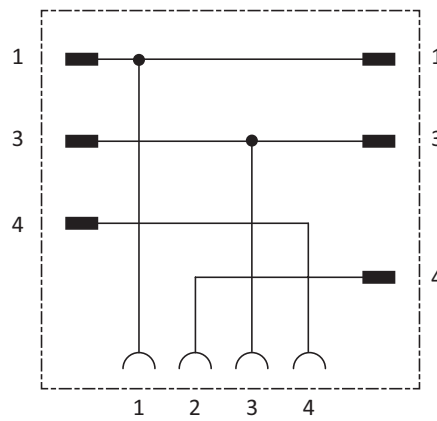
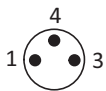

M8 female

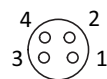

M8 male

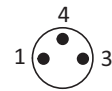





Wiring diagram and Pin assignment for 20.554

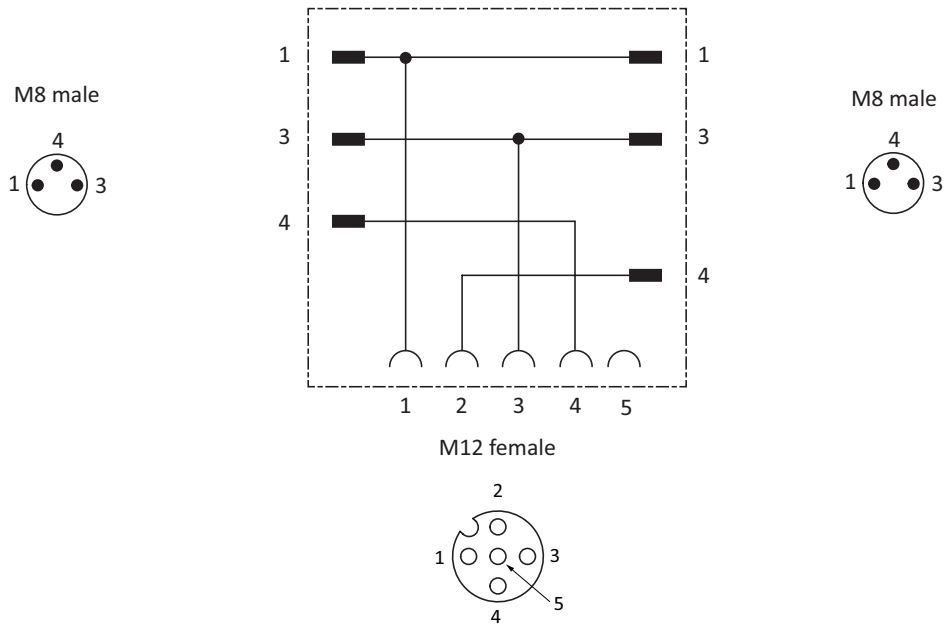

Wiring diagram and Pin assignment for 20.555

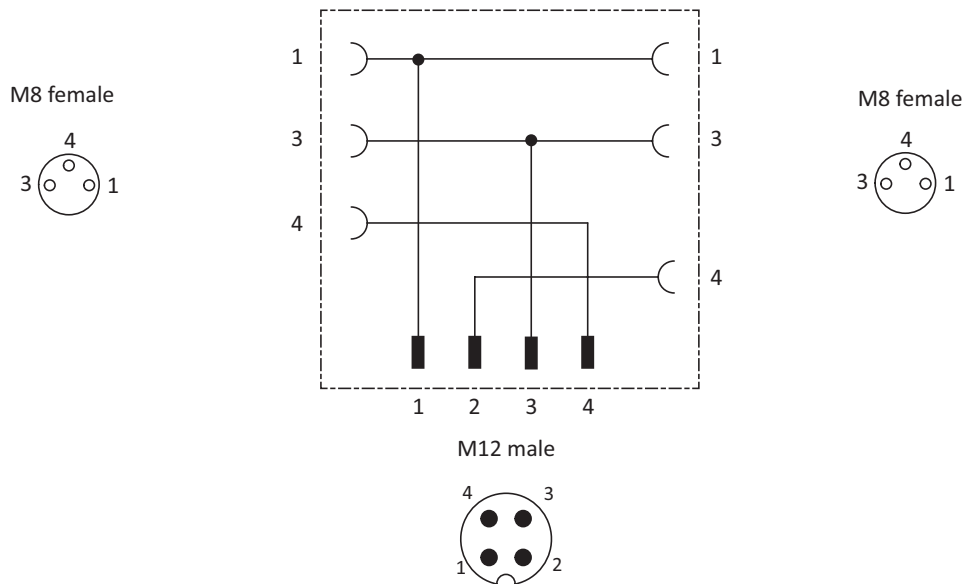

Continued on the next page →



### Wiring diagram and Pin assignment for 20.556

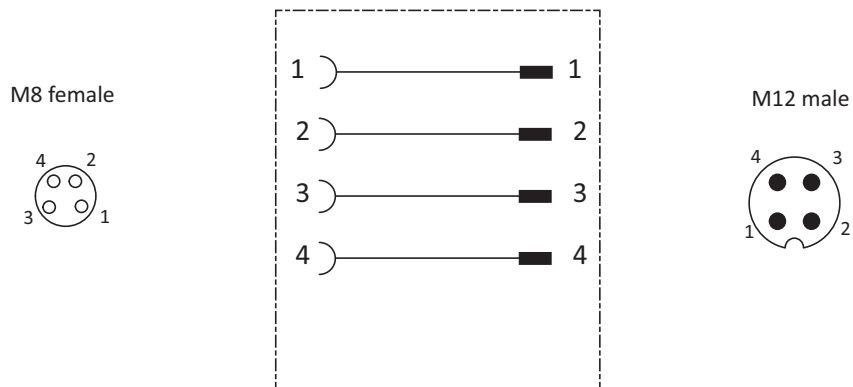

### Dimensions

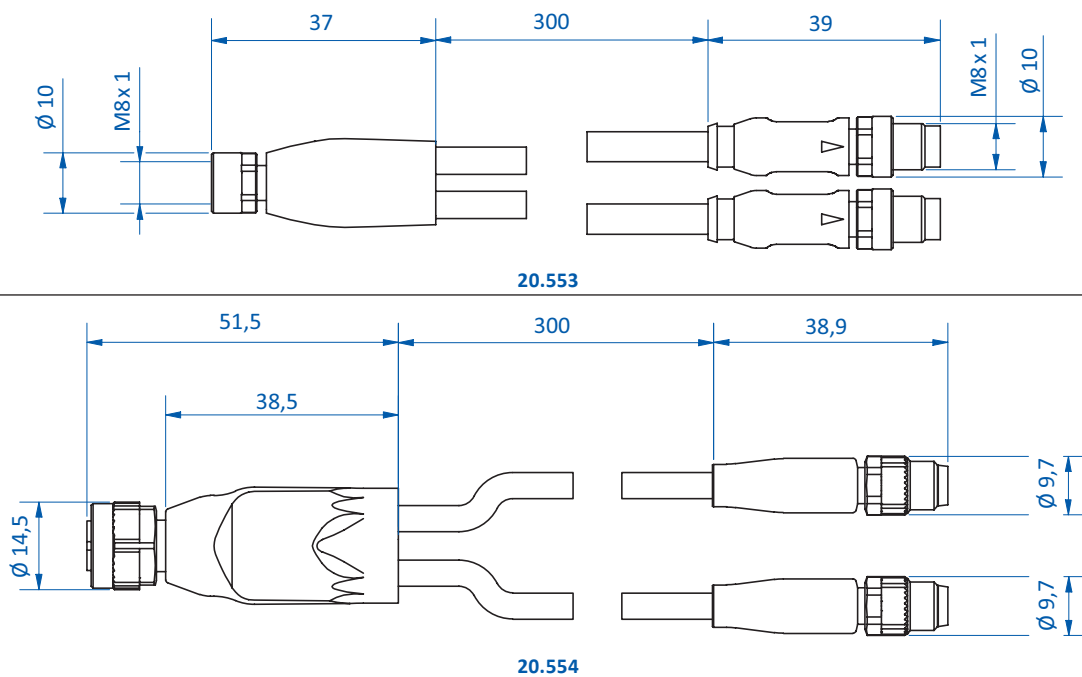



Dimensions

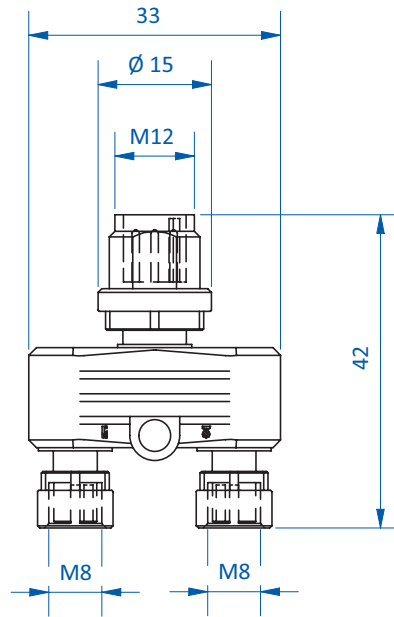

20.555

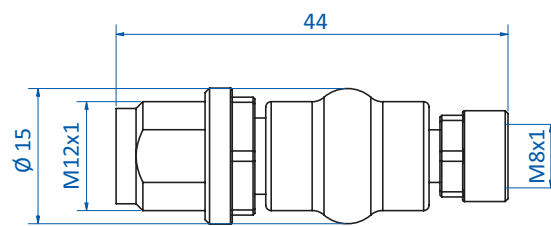

20.556



### Photoelectric Sensor with background suppression



#### Product notes

- > Sensor for optical parts confirmation
- > Background suppression
- > Red light
- > qTeach is locked 5 minutes after being switched on, to avoid unwanted setup changes
- > short circuit and reverse polarity protection

#### Technical data

Item no.	GS03.010
Adjustable range [mm]	30 - 300
Switching output	PNP
Operating voltage [V]	10 - 30
Max. current consumption (without load) [mA]	45
Current consumption middle [mA]	30
Response time [ms]	< 1
Protection class	IP67
Background suppression	yes
Electric connection	3-pin male M8 connector
Ambient air temperature [°C (°F)]	-25 - 60 (-13 - 140)
Weight [g]	13.3
Accessories	Mounting bracket: GS03.14045 Mounting bracket: GS03.14090 Mounting bracket: GS03.14130 Connecting cable: 20.503 Connecting cable: 20.507 Extension cable: 20.504 Extension cable: 20.570

#### Wiring diagram and Pin assignment

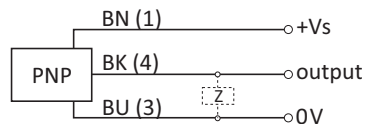

BN = Braun/brown  
BK = Schwarz/black  
BU = Blau/blue

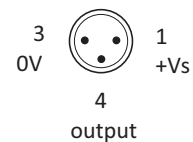



Beam characteristic

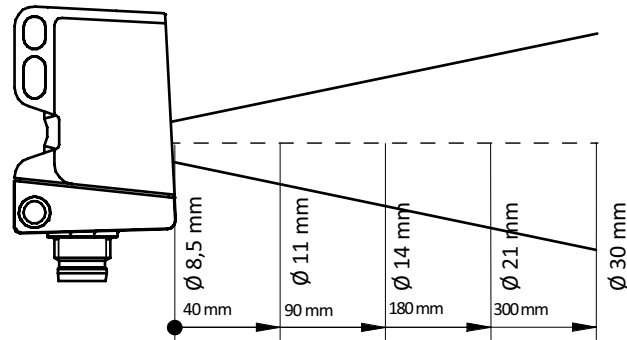

Sensing distance diagram

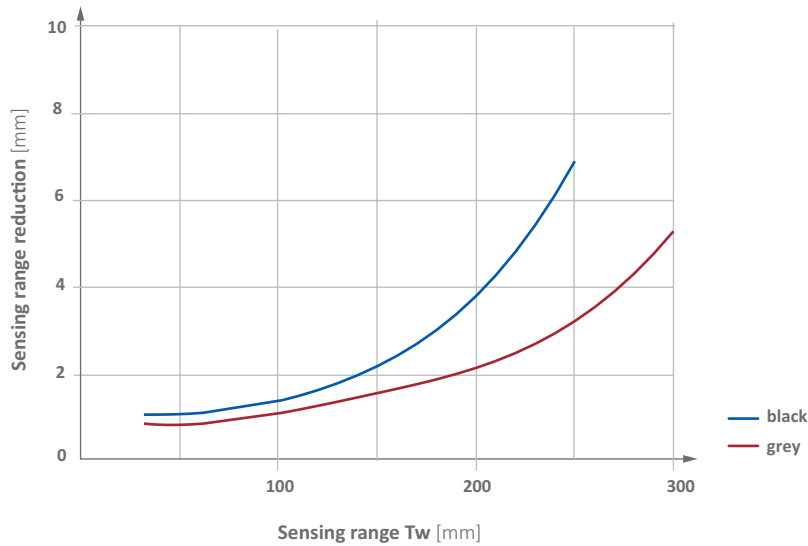

Dimensions

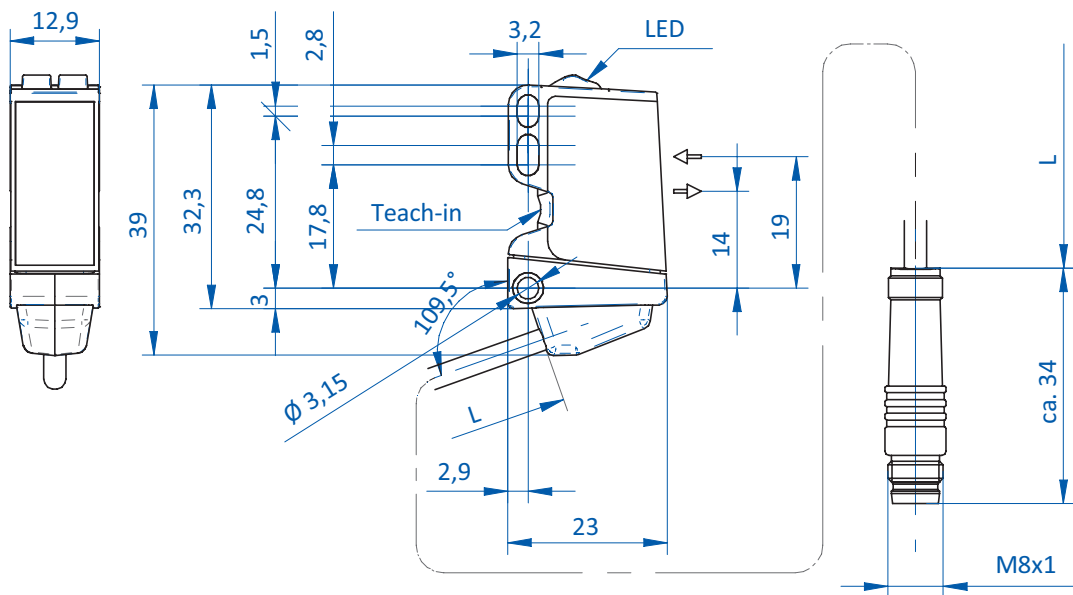



### Elbow arm for sensors, clamping diam. 14 mm

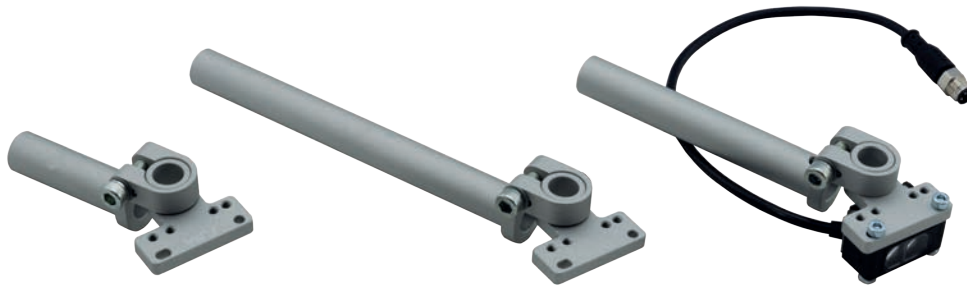

#### Product notes

- > Simple mounting option for sensors
- > Suitable for most commercially available compact sensors with holes or threads in 15 mm, 24.5 mm and 26.8 mm hole spacing
- > Mounting material for GS03.010 diffuse reflection sensor included in the scope of delivery

#### Technical data

Item no.	Length clamping shaft [mm]	Weight [g]	Accessories
GS03.14045	45	31	Cross clamp: GR02.023 Angle clamp: GR02.004
GS03.14090	90	40	Cross clamp: GR02.023 Angle clamp: GR02.004
GS03.14130	130	48	Cross clamp: GR02.023 Angle clamp: GR02.004

#### Dimensions

$\varnothing$ A [mm]	B [mm]	C [mm]	D [mm]	E [mm]	L [mm]
14	35	85	28	16	45
14	35	130	28	16	90
14	35	170	28	16	130

#### Application example

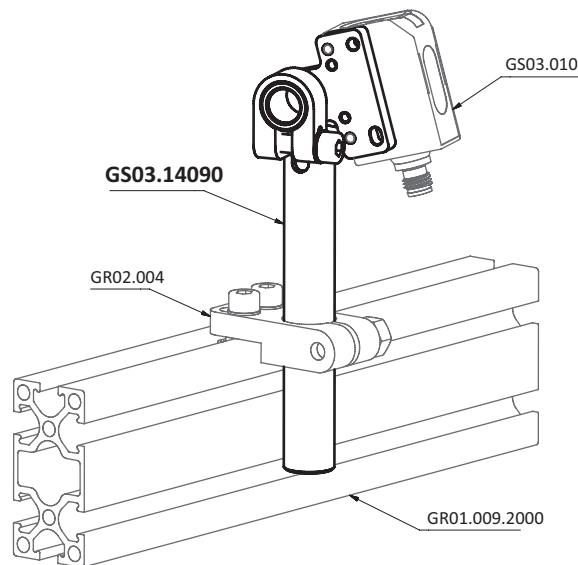



Dimensions

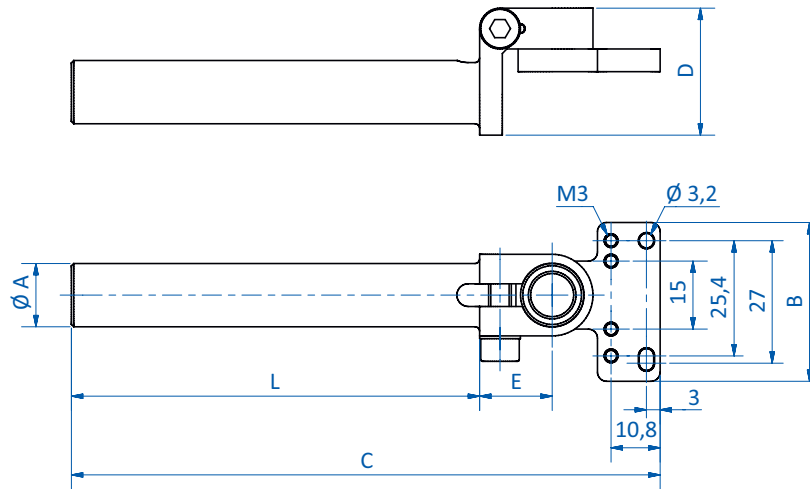



### Sensor-relay-switchboxes



#### Product notes

- > Reduction of necessary inputs on the robot control via bundling (series switching logic AND) of several sensor signals
- > Inputs PNP, NPN or potential-free contact (NO or NC)
- > Outputs PNP, NPN or potential-free contact (NO)
- > Input LEDs for simplified troubleshooting
- > Terminals for cable cross-section AWG 22..26
- > Assembly on SLine, MLine or XLine extrusions
- > Connection of several switchboxes possible
- > Slot nuts and screws for SLine/MLine included in scope of delivery

#### Technical data

Item no.	Max. number of inputs	Max. number of outputs	Operating voltage [V]	Protection class	Weight [g]
<b>GS01.004</b>	4	4	24	IP65	180
<b>GS01.006</b>	6	6	24	IP65	171
<b>GS01.008</b>	8	8	24	IP65	230
<b>GS01.012</b>	12	12	24	IP65	325

#### Wiring diagram

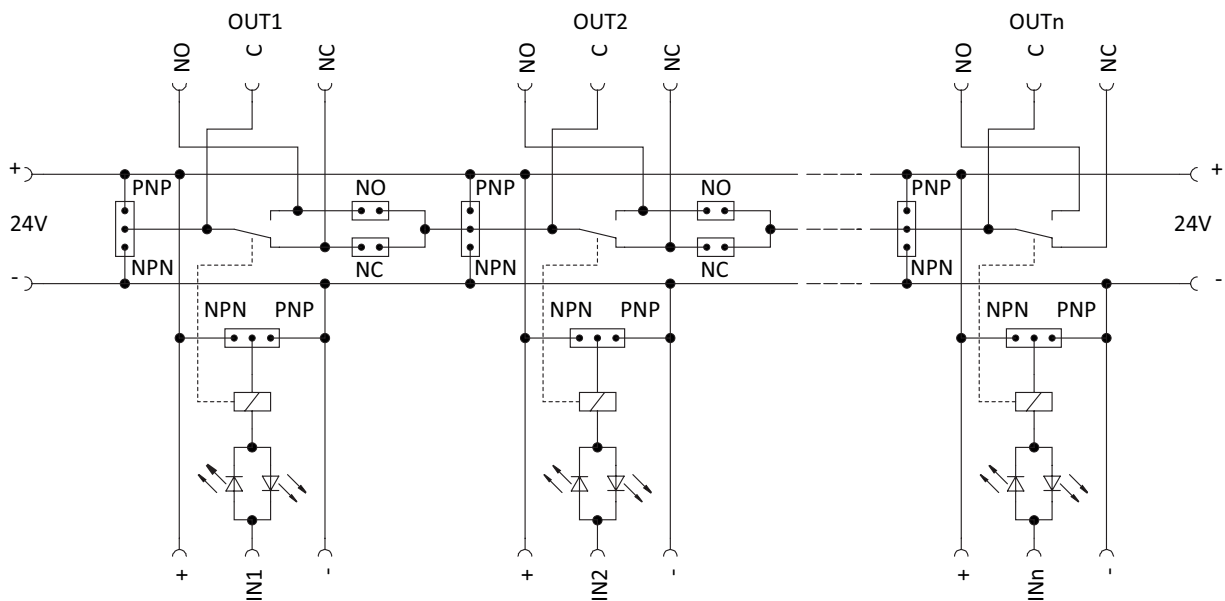





Dimensions

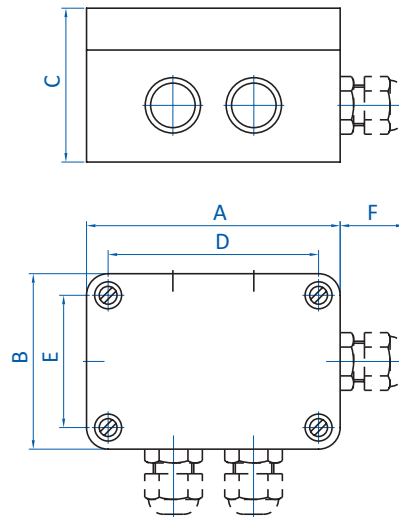

Item no.	A [mm]	B [mm]	C [mm]	D [mm]	E [mm]	F [mm]
GS01.004	94	65	57	79	50	25
GS01.006	94	94	57	79	79	25
GS01.008	130	94	57	115	79	25
GS01.012	180	94	57	165	79	25



### T-coupler bundlers with and/or logic

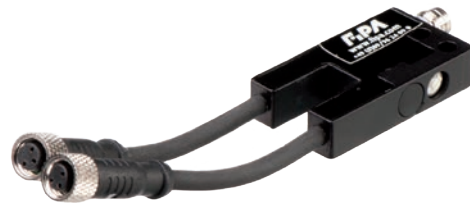

20.526

#### Product notes

- > T-coupler connects 2x M8-female with 1x M8-male
- > Interconnection of sensor signals on gripper systems
- > If more than five sensors need to be connected we recommend to use switchboxes such as GS01.006 instead of T-couplers
- > Manual adjustment of shift logic at 20.526

#### Technical data

Item no.	Electric connection	Operating voltage [VDC]	Protection class	Logic	Weight [g]
20.524	PNP/NPN	24	IP67	2x or	15
20.525	PNP	24	IP67	2x and	15
20.526	PNP	10 - 35	IP67	2x and/or	25

#### Pin assignment and connection diagram for 20.524

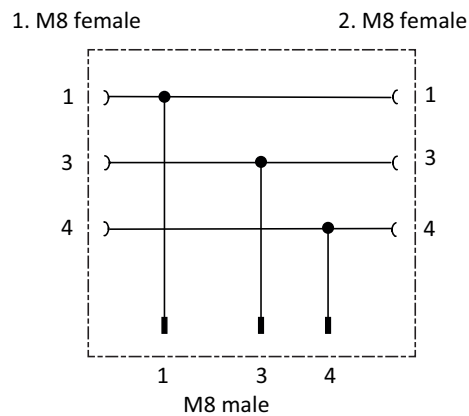
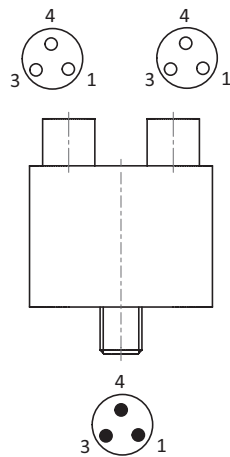



## Pin assignment and connection diagram for 20.525

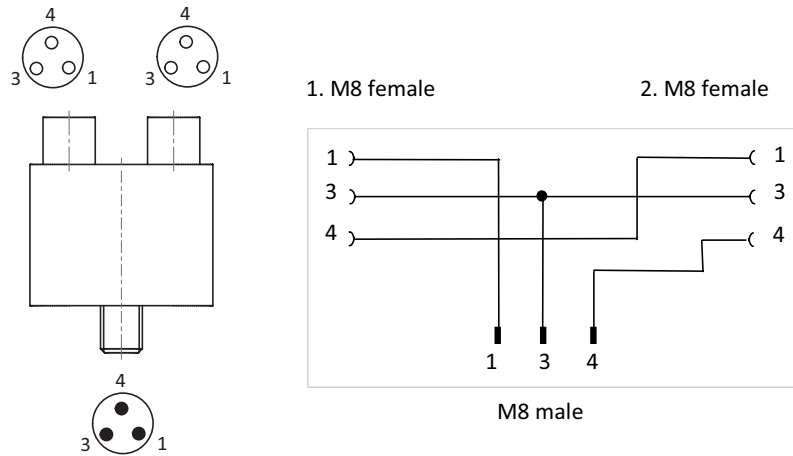

## Connection diagram for 20.526

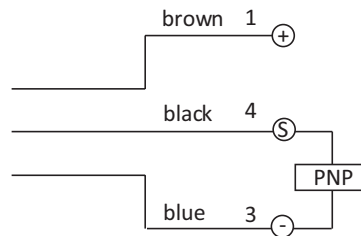

## Application example



Continued on the next page →



### Dimensions

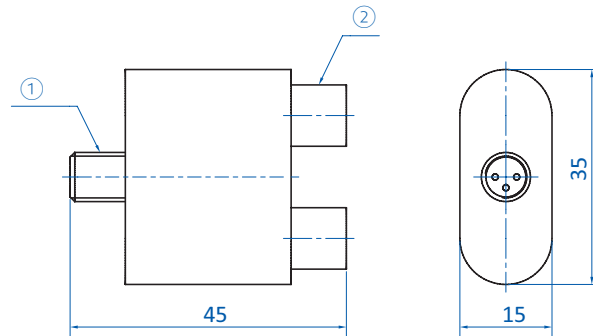

20.524 | 20.525

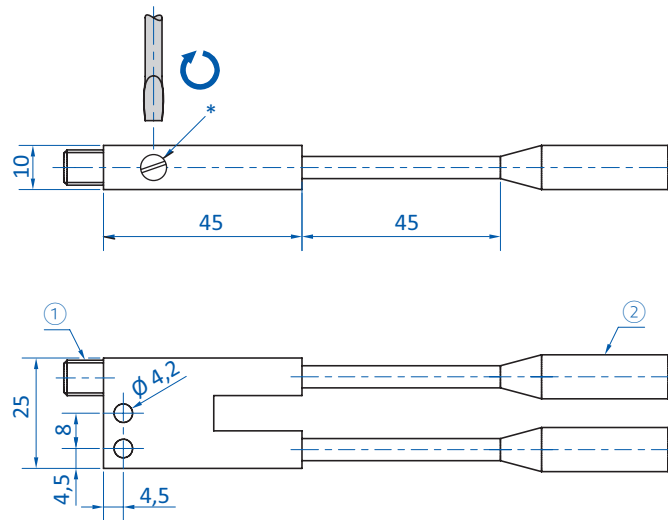

20.526

① = Plug, 3-pin M8x1    ② = Socket, 3-pin M8x1    \* = Adjustment screw for and/or logic



### Signal converters M8 / signal inverter M8



**CONVERT SENSOR SIGNALS INDEPENDENT OF ROBOT CONTROLLER**

#### Product notes

- > PNP inverter 20.530 inverts the input signal
- > PNP-NPN converter 20.531 suitable for the integration of PNP sensors in NPN circuits
- > LED status and LED switching status display
- > Suitable for common sensors
- > Application example: By connecting 20.530 in front of grippers with indirect sensing, a signal can be triggered when a part is gripped

#### Technical data

Item no.	20.530	20.531
Input signal	PNP	PNP
Output signal	PNP	NPN
Connection	M8x1	M8x1
Max. ampacity [mA]	200	200
Operating voltage [VDC]	10 - 35	10 - 35
Current consumption [mA]	< 20	< 20
Max. switching frequency [Hz]	3,500	5,000
Minimum pulse duration [ms]	> 0.1	> 0.1
Protection class	IP67	IP67
Ambient air temperature [°C (°F)]	-20 - 70 (-4 - 158)	-20 - 70 (-4 - 158)
Weight [g]	17	17

#### Signal

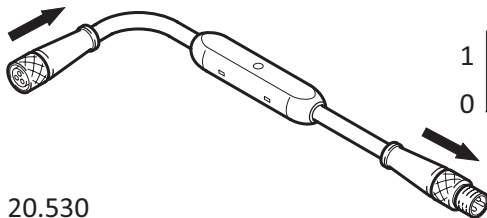
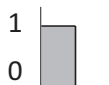

20.530

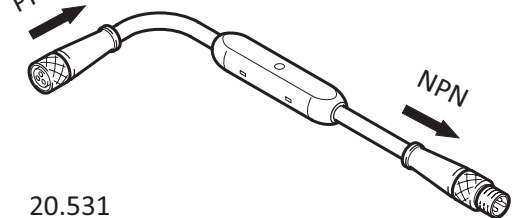
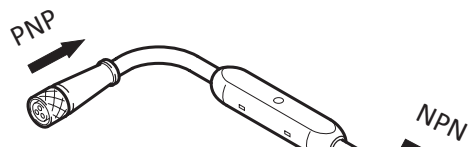

20.531

Continued on the next page →



### Plug assignment

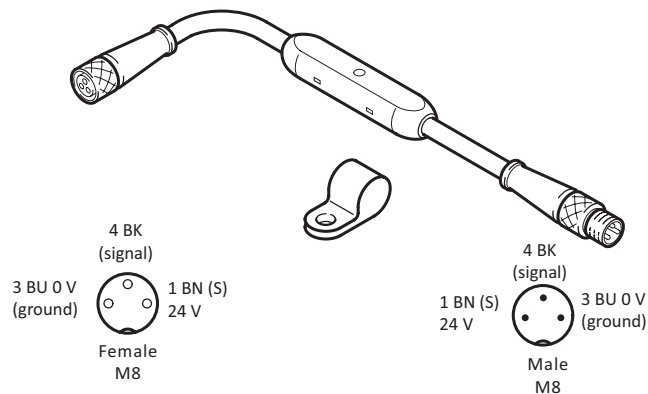

### Dimensions

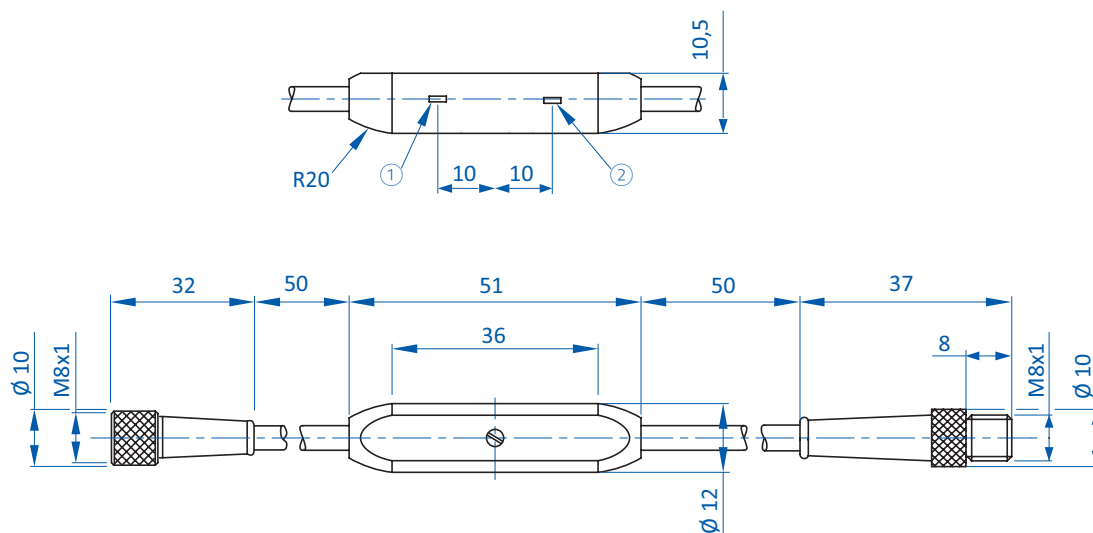

① = LED status ② = LED switching output



Your global partner for

# vacuum, gripping and lifting technology

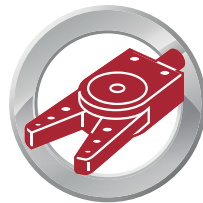

Our general terms and conditions apply, which you can find on the Internet at [www.fipa.com](http://www.fipa.com), or by telephone on +49 89 962489-0 on request.

#### Copyright

All pages and their components are protected by copyright (all rights reserved). The designations, trademarks, logos, texts and images are the property of their respective owners and are to be as such.

Realization: FIPA GmbH, Ismaning

#### Disclaimer

This catalog was created with the greatest possible care. Nevertheless FIPA cannot guarantee the correctness and accuracy of the information contained herein. FIPA excludes any liability for damages arising directly or indirectly from the use of the FIPA catalog, insofar as damage is not caused by intent or gross negligence on the part of FIPA. FIPA shall not be liable for damage caused by finished assemblies already pre-assembled, finished assemblies if these have not been checked for suitability by the customer for their suitability for the respective application.

FIPA GmbH  
Freisinger Straße 30  
85737 Ismaning  
Telefon +49 89 962489-0  
Telefax +49 89 962489-11  
[info@fipa.com](mailto:info@fipa.com) | [www.fipa.com](http://www.fipa.com)

Executive Manager: Rainer Mehrer  
Headquarters: Ismaning  
Commercial Register:  
München, HRB 104 684  
Sales Tax ID No: DE161864784



[www.fipa.com](http://www.fipa.com)